

# VF66B

## TOYO INTELLIGENT INVERTER

### Operating Manual

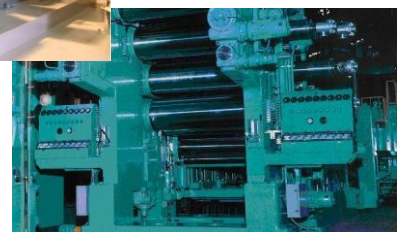



# Table of Contents

<b>Preface</b> .....	7
<b>Be Sure To Read This Before Use</b> .....	8
Safety Notice .....	8
<b>Chapter 1 Checking and Inspecting Package</b> .....	12
1.1 Checking Package and Inspection on Purchase .....	12
<b>Chapter 2 Product Overview</b> .....	14
2.1 Features .....	14
2.2 Configuration .....	16
<b>Chapter 3 How to Install and Connect Inverter</b> .....	18
3.1 Surrounding Environment and How to Install It .....	18
3.1.1 Installation Environment .....	18
3.1.2 How to Install Inverter .....	18
3.2 How to Open and Close Front Cover .....	21
3.2.1 How to Open Front Cover .....	21
3.2.2 How to Close Front Cover .....	25
3.3 How to Connect Inverter .....	28
3.3.1 How to Connect Inverter Terminals .....	28
3.3.2 How to Connect Speed Sensor and PG Input Board .....	29
3.4 Terminal Specifications .....	32
3.5 Notes for Wiring and Electrical Wire Size .....	37
3.5.1 Notes for Wiring .....	37
3.5.2 Electrical Corrosion Measures .....	38
3.5.3 Input / Output Devices and Electrical Wire Size of Main Circuit Wires .....	39
3.5.4 Electrical Wire Size of Control Board and PG Input Board .....	44
3.6 Inverter Selection and List of Applied Motors .....	45
<b>Chapter 4 Basic Operating Procedures for Inverter</b> .....	47
4.1 Basic Operating Procedures from Console .....	47
4.1.1 Explanation of Display and Operation Keys on Console .....	47
4.1.2 What Are Displayed at Power-on .....	53
4.1.3 Changing Parameter Settings .....	55
4.1.4 Changing Parameter Simple Mode and Full Mode .....	60
4.1.5 Changing Inverter Control Methods .....	66
4.1.6 Checking Operating State .....	70
4.1.7 List of Monitor Items .....	71
4.2 Operation Flow of Inverter .....	75

4.3	Autotuning of Parameters (Automatic Setting)	78
4.3.1	What Is Autotuning of Parameters?	78
4.3.2	Requirements for Performing Autotuning	80
4.3.3	How to Perform Autotuning	83
4.4	Operations on Console	92
4.4.1	Rotating Motor with Specified Frequency/Speed	92
4.4.2	Changing Acceleration or Deceleration Time	94
4.4.3	Changing Rotation Direction	96
4.4.4	How to Perform JOG Operation	97
4.4.5	Changing JOG Frequency/Speed	98
4.4.6	Changing JOG Acceleration or Deceleration Time	100
4.5	Start and Stop through External Contact in V/f Control	103
4.6	Changing Speed through Voltage Setting Device/Variable Resistor in V/f Control	107
<b>Chapter 5</b>	<b>Explanation of Parameters</b>	<b>109</b>
5.1	List of Parameters That Can Be Changed in Simple Mode	109
5.1.1	V/f Control	109
5.1.2	Induction Motor Vector Control	115
5.1.3	ED Motor Vector Control	122
5.2	List of Parameters in Full Mode	130
5.3	Detailed Explanation of Parameters	139
5.3.1	Basic Setting Area	139
5.3.2	Area A (Setting Area for Maximum Frequency/Maximum Speed, Rated Motor, and Other Parameters)	144
5.3.3	Area b (Setting Area for Operation Mode and Operation Sequence)	157
5.3.4	Area c (setting area for parameters related to multifunction input)	171
5.3.5	Area d (setting area for acceleration or deceleration time, frequency/speed jump functions, and MRH functions)	182
5.3.6	Area E (setting area for frequency characteristics, torque limit, torque command characteristics, and speed control)	187
5.3.7	Area F (setting area for built-in dynamic brake (DB) operation, protection functions, and traceback)	195
5.3.8	Area G (setting area for analog input and output)	204
5.3.9	Area H (setting area for multifunction output)	210
5.3.10	Area i (setting area for internal PLC, droop control, and mechanical loss compensation)	219
5.3.11	Area J (setting area for digital communication options)	228
5.3.12	Area L (setting area for input and output gain)	231
5.3.13	Area n (monitor adjustment area)	232
5.3.14	Area o (special adjustment area)	233
5.3.15	Area P (setting area for internal PLC and P register)	234
5.3.16	Area S (setting area for mode selection and analog input/output adjustment)	235
5.4	Operation Using S Area Parameters	239

5.4.1	How to Clear Protections .....	239
5.4.2	Data Transfer from/to External Console Option .....	240
5.4.3	Direct-current Voltage Detection Gain Adjustment .....	252
5.4.4	Analog Input (1) Gain and Offset Adjustment .....	256
5.4.5	Analog Input (1) Gain Adjustment (for 4 to 20 mA input characteristics) .....	262
5.4.6	Analog Output (1) Gain and Offset Adjustment .....	267
5.4.7	Analog Input (2) through (5) Gain and Offset Adjustment .....	274
5.4.8	Analog Output (2) through (5) Gain and Offset Adjustment .....	281
<b>Chapter 6</b>	<b>Troubleshooting</b> .....	<b>288</b>
6.1	Protection Messages and Actions .....	288
6.1.1	Displays and Behaviors in Protection Display Mode .....	288
6.1.2	List of Protection Messages .....	289
6.1.3	How to Handle Protection Messages .....	296
6.1.4	Meaning of Setting Error (SE--) Display .....	312
6.1.5	Meaning of Error Displays during Autotuning .....	317
6.2	How to Check Data in Protection Display Mode .....	319
6.2.1	How to Display Protection Operation Data .....	319
6.2.2	List of Data of Protection Operation and Protection History Display .....	319
6.3	How to Reset Protection Display Mode .....	321
6.4	How to Check Protection History .....	322
<b>Chapter 7</b>	<b>Maintenance and Inspection</b> .....	<b>324</b>
7.1	Periodic Inspection .....	324
7.2	When [ALM] LED on Console Turns On .....	325
7.3	How to Replace Cooling Fan .....	326
7.3.1	How to Remove Cooling Fan .....	326
7.3.2	How to Install Cooling Fan .....	329
7.4	Inspecting and Replacing Main Circuit Capacitor .....	330
7.5	How to Perform Insulation Resistance Test .....	330
7.6	How to Discard Parts .....	331
<b>Chapter 8</b>	<b>Replacing Control Board</b> .....	<b>332</b>
8.1	Tasks Required for Replacing Control Board .....	332
8.2	How to Replace Control Board .....	332
8.3	How to Initialize Inverter Main Unit .....	338
8.4	How to Adjust Analog Input Gain .....	343
<b>Chapter 9</b>	<b>Standard Specifications</b> .....	<b>350</b>
9.1	Common Specifications .....	350
9.2	List of Capacity .....	354

<b>Chapter 10 Outline Drawing of Inverter</b> .....	359
10.1 Standard Type .....	359
10.2 Non-standard Type (Heat Generation Part Protruded Outside) .....	362
<b>Chapter 11 Supporting Overseas Standards</b> .....	365
<b>Chapter 12 Attentions for Contacting Us</b> .....	366
<b>Chapter 13 Industrial Product Warranty</b> .....	367
13.1 No-charge warranty period .....	367
13.2 Warranty scope .....	367
13.2.1 Problem diagnosis .....	367
13.2.2 Repair .....	367
13.3 Disclaimer .....	368
13.4 Repair period after product discontinuation .....	368
13.5 Delivery conditions .....	368

## Preface

Thank you very much for choosing our inverter.

This manual describes how to handle a main unit of the inverter.

It provides instructions for using the inverter, such as how to install, wire, and operate it correctly as well as handling methods of its protection operation.

Before operating it, be sure to carefully read this manual.

Also, keep this manual in an appropriate place so that operators can always take and read it.

In addition to the standard functions, the inverter provides many features. You can build an optimal system for different applications by using its various functions. In such a case, preferentially use the values described in the dedicated "Instruction Manual" and "Test Report" for the function.

When delivering any of your products with our inverter built in, consider that this manual can be distributed to end users. Also, when changing our factory default initialized data (hereinafter referred to as Initialized data) for setting parameters of the inverter, make sure that end users can be informed about the changed contents of the Initialized data.

### **Product Overview**

The inverter can drive an induction motor and a Interior Permanent Magnetic Synchronous Motor (ED motor), and it can support various applications, using V/f control, vector control without sensor, and vector control with sensor.

However, please note that the inverter for Europe can only drive ED motors.

You can set two types of operation control methods and motors.

Long-life parts are used for components which require replacement (such as a main circuit capacitor and a cooling fan), which can reduce maintenance cost.

## Be Sure To Read This Before Use

### Safety Notice

To use the inverter correctly, be sure to completely read this manual and all other attached documents before installation, operation, maintenance, and inspection.

You need to have a good knowledge of equipment, safety information, and all notices before using the inverter. In this manual, safety notices are ranked as "Danger," "Warning," and "Caution."

#### DANGER

When improper use may cause a dangerous situation, death or serious injury may result, and its danger seems to be very urgent.

#### DANGER

When improper use may cause a dangerous situation, death or serious injury may result, and its danger seems to be very urgent.

#### WARNING

When improper use may cause a dangerous situation, and death or serious injury may result.

#### WARNING

When improper use may cause a dangerous situation, and death or serious injury may result.

#### CAUTION

When improper use may cause a dangerous situation, medium-level or minor injury may result, and only physical damage may result. However, it may cause serious results depending on the situation. Cautions described in this manual are all important. Be sure to observe them.

#### CAUTION

When improper use may cause a dangerous situation, medium-level or minor injury may result, and only physical damage may result. However, it may cause serious results depending on the situation. Cautions described in this manual are all important. Be sure to observe them.

## CAUTION Installation

- Install the inverter on non-inflammables such as metal.  
Otherwise, a fire may occur.
- Do not put inflammables near the inverter.  
Otherwise, a fire may occur.
- A model over 22 kW is considered as a heavy material. Don't lift it by yourself. Otherwise, you may be injured.
- Do not hold the front cover when transporting the inverter.  
It may fall, which may result in injury.
- Install the inverter in a place which can support its weight.  
It may fall, which may result in injury.
- Do not install and operate the inverter which is damaged or does not have any parts.  
Otherwise, you may be injured.
- Do not install the inverter in an atmosphere which contains plasticizer such as halogen and DOP (phthalate ester).  
Otherwise, it may be damaged.

## DANGER Wiring

- Check that the input power is turned off before wiring.  
Otherwise, electric shock or a fire may occur.

## WARNING Wiring

- Be sure to connect a ground wire.  
Otherwise, electric shock or a fire may occur.
- Electrical engineering technicians should connect wires.  
Otherwise, electric shock or a fire may occur.
- Be sure to install the inverter before wiring.  
Otherwise, electric shock or a fire may occur.
- For ground fault protection, connect a leakage protection relay or leakage circuit breaker to inverter input terminals [L1/R, L2/S, and L3/T].  
Otherwise, electric shock or a fire may occur.
- Do not connect the alternating-current power supply to inverter output terminals [T1/U, T2/V, and T3/W].  
Otherwise, injury or a fire may occur.
- Check that inverter power rating matches alternating-current power supply voltage.  
Otherwise, injury or a fire may occur.
- Do not directly connect a resistor between direct-current terminals [+1]/[+2] and [−] or [+1] and [+2].  
Otherwise, a fire may occur.

## WARNING Operation

- Be sure to install the front cover before turning on the input power. Do not remove the front cover during energization. Otherwise, it may result in a risk of electric shock.
- Do not use operation keys by wet hands. Otherwise, it may result in a risk of electric shock.
- Do not touch terminals such as main circuit terminals and a protective earth terminal during energization. Otherwise, it may result in a risk of electric shock.
- The stop button ([STOP/RESET] key) is available only when functions have been set. Provide an emergency stop button separately. Otherwise, you may be injured.
- When alarm reset is performed with operation signals input, the inverter suddenly restarts. Check that signals are turned off, and then perform alarm reset. Otherwise, you may be injured.

## CAUTION Operation

- Do not touch a heat sink and a discharge resistor because they reach high temperatures. Otherwise, you may get burned.
- You can set speed of the inverter from low to high. Before operation, check the permitted range of the motor and machinery sufficiently. Otherwise, you may be injured.
- Provide a holding brake separately if necessary. Otherwise, you may be injured.

## WARNING Maintenance and inspection, and replacement of parts

- Before inspection, turn off the input power after checking that the motor is stopped, and then wait for over ten minutes. Also, check that direct-current voltage between the direct-current terminals [+1] and [-] or [+2] and [-] is less than or equal to 30 V. Otherwise, electric shock, injury, or a fire may occur.
- Check that inverter power rating matches alternating-current power supply voltage. Otherwise, injury and electric shock may occur, or parts may be damaged.
- Do not perform maintenance and inspection or replace parts except qualified persons. Use a tool for insulation for maintenance and inspection. Otherwise, electric shock or injury may occur.

## WARNING Others

- Never modify the inverter. Otherwise, electric shock or injury may occur.

 **CAUTION** General notice

● To provide detailed explanation, all figures described in this manual are sometimes drawn with the cover or a safety shield removed.

To operate the inverter, be sure to set the specified cover or shield to its original position and to follow the procedure described in this manual.

● When the inverter is packed with fumigated wooden materials, its electronic components may be fatally damaged.

Be sure to use ways other than fumigation for sterilization and insect removal. Also, process them before packing.

● These safety notices and specifications in this manual are subject to change without notice.

## Chapter 1 Checking and Inspecting Package

### 1.1 Checking Package and Inspection on Purchase

After receiving the inverter, check the package, and then inspect the product and accessories.

If you have any problem, contact us or the distributor.

(1) Check that the package contains the inverter main unit and the Precautions.

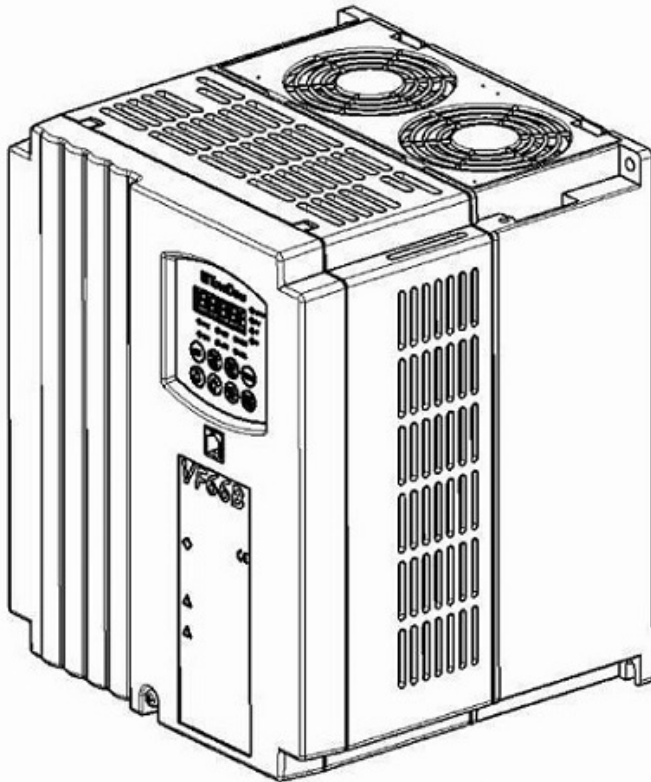

Inverter main unit



Precautions

(2) Check that the specifications, accessories, spares, and options are delivered as you order. The label on the surface of the cover mentions the inverter-type.

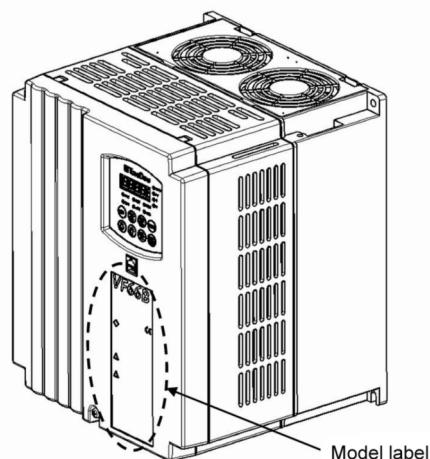

Model label

**Example of the model label on the surface of the cover**

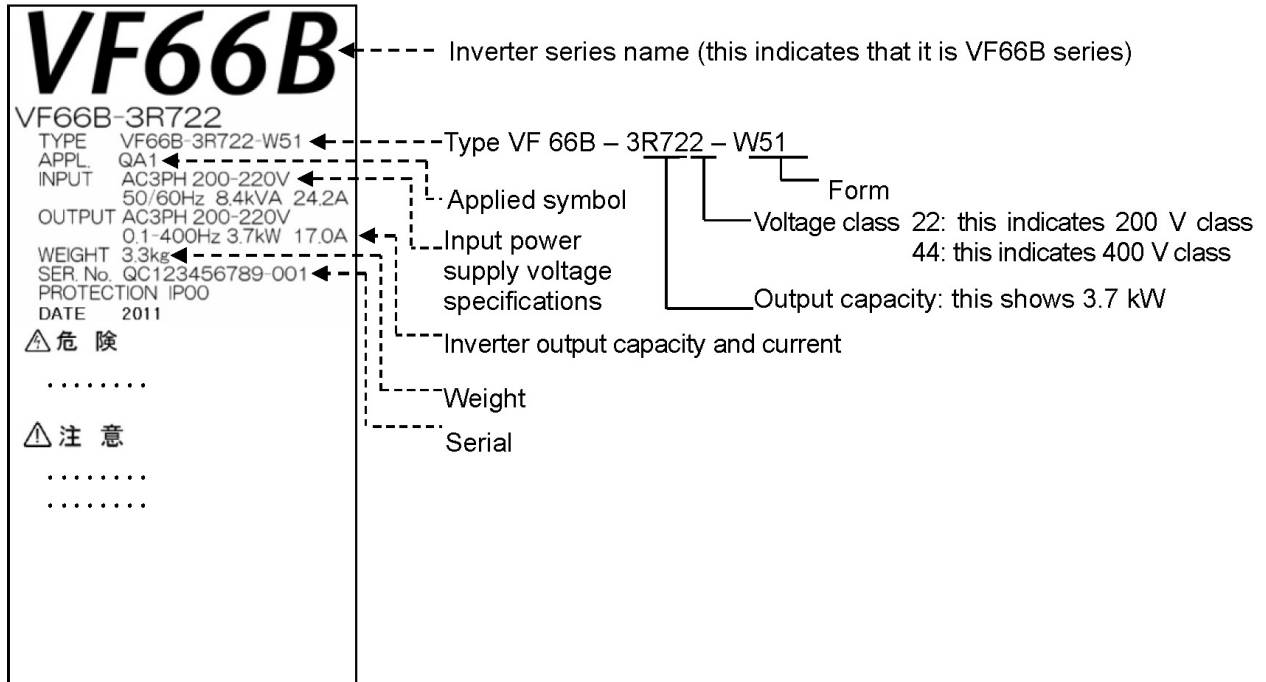

(3) Check the product for damages and loose or removed screws during transportation.

 <b>CAUTION</b> Safety notice
<p>To use the inverter correctly, read this manual completely.</p> <p>Our inverter is not designed and produced for the purpose of being used for a device or system under a situation where human life may be threatened.</p> <p>Do not use this inverter for special purposes such as riding, medical, aerospace, nuclear power control, and a submarine repeater or system.</p> <p>This inverter is produced under the strict quality control. However, when it is applied to an important facility where its failure might threaten human life or cause expected serious losses, you should install any safety devices to prevent serious accidents.</p> <p>When using it for load other than a three-phase alternating current motor, consult with us.</p> <p>This inverter requires electrical work. Electrical engineering technicians should do it.</p>

## Chapter 2 Product Overview

### 2.1 Features

■ Provide three types of control methods to support various applications

The inverter can drive the induction motor and the Interior Permanent Magnetic Synchronous Motor (ED motor) to support various applications.

- V/f control  
Applications for controlling the general induction motor at variable speed
- Vector control without sensor (induction motor, ED motor)  
Applications for requiring higher torque or more accurate speed control than V/f control
- Vector control with sensor (induction motor, ED motor)  
Applications for requiring higher torque and high-accuracy speed control

■ Standard feature of Autotuning

The inverter provides an Autotuning function where the inverter itself measures motor parameters such as motor resistance and inductance and also automatically sets parameters.

It can be optimally operated with control methods of [V/f control], [Induction motor vector control], and [ED motor vector control].

■ Simple mode in which parameters can be easily set

The "simple mode," in which the display of parameters is minimized, enables you to prevent incorrect settings. You can check operations promptly when introducing the inverter.

■ Operation possible in two control modes

You can set two types of control methods and motors.

To switch two modes (control methods or motors), you only have to set control method or motor parameters and then input external signals to the inverter.

■ Reduced maintenance cost

Long-life parts are used for components which require replacement.

- Main circuit capacitor: About ten years (life expectancy in design)
- Cooling fan: About five years (life expectancy in design)

For 2.2 to 7.5 kW (200 V/400 V class), you can easily replace the cooling fan without mounting screws.

With a cumulative operation timer, you are automatically notified when to replace components (alarm function).

■ Reduced running cost

The ED motor operated with high efficiency enables you to save energy. For the motor with larger volume and longer use, you can reduce more running cost.

■ Support for design and adjustment tool on personal computer

It provides a personal computer tool <VF66 PC Tool> as an option to offer powerful support from adjustment at the introduction of the inverter to maintenance.

## [Induction motor vector control] and [ED motor vector control]

### [Induction motor vector control]

The vector control enables you to control torque of the induction motor and to achieve high-speed and high-accuracy speed control.

Since it develops higher torque at start, it can be used for line control such as a paper machine and film processing as well as an extruder for rubber, plastic, and metal, a centrifuge, and a mixer. Also, since it has a wider constant output (power constant) area, it can be applied to a winder and can be used under a poor working environment with the speed control without sensor.

### [ED motor vector control]

The vector control enables you to control torque of the ED motor and to achieve high-speed and high-accuracy speed control.

When compared with the [induction motor vector control], this is optimal for the extruder for rubber, plastic, and metal which requires continuous operation for energy saving.

## 2.2 Configuration

### ■ Inverter main unit

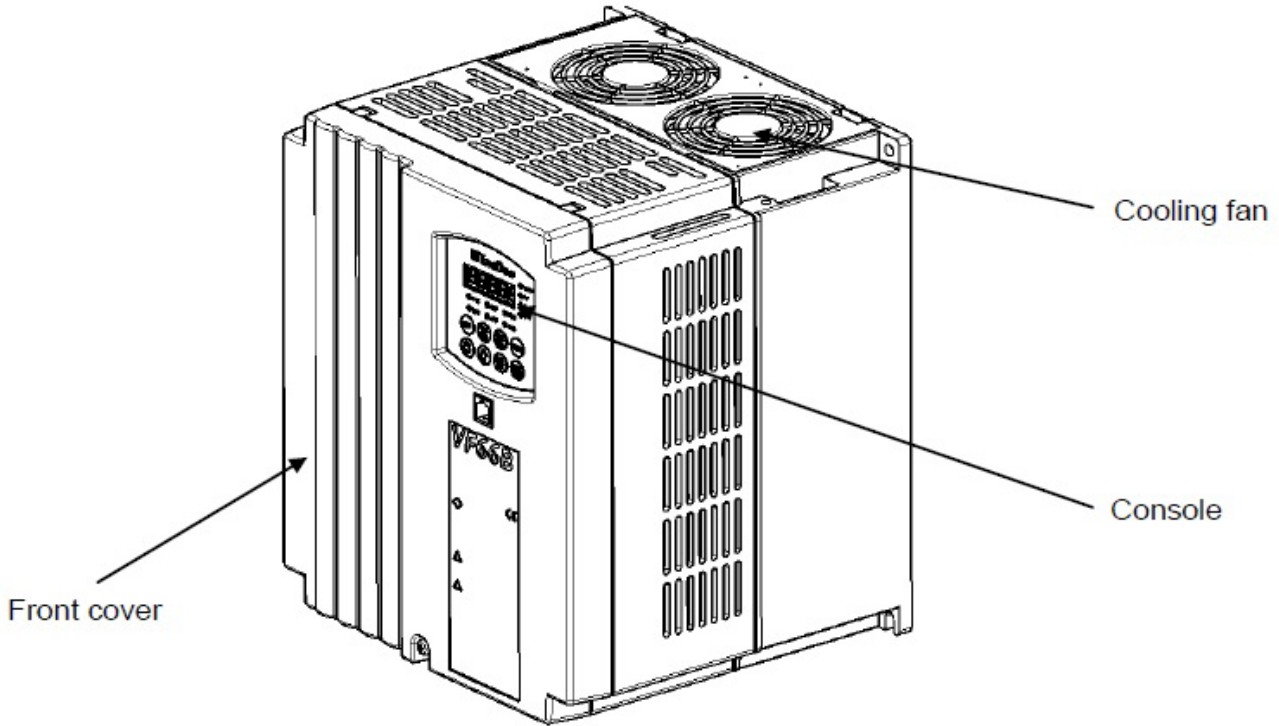

- **Front cover**  
This is a front cover of the inverter. For how to remove it, refer to {3.2.1 How to Open Front Cover}.
- **Cooling fan**  
This is a fan motor for cooling. For how to replace it, refer to {7.3 How to Replace Cooling Fan}.
- **Console**  
It is used for operation from the inverter main unit.  
It consists of a seven-segment display, a unit LED, a status display LED, and operation keys.  
For details, refer to {4.1.1 Explanation of Display and Operation Keys on Console}.

## ■ Board

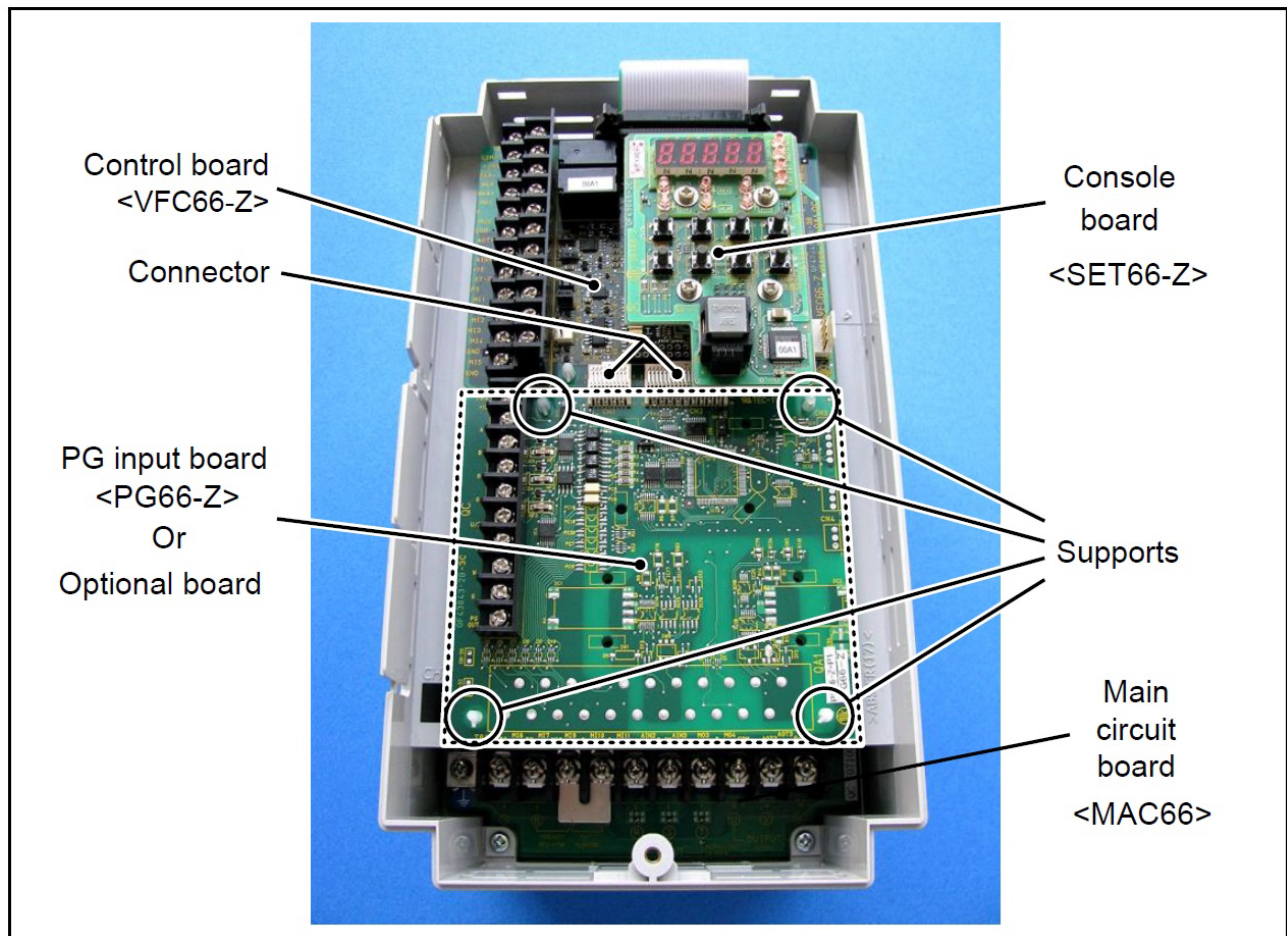

- Main circuit board <MAC66> (for 2.2 to 7.5 kW only)**  
 This is a main circuit part of the inverter. A terminal block is located in the lower part of it. For details of wiring, refer to {3.3.1 How to Connect Inverter Terminals} and {3.5 Notes for Wiring and Electrical Wire Size}. For details of the terminal block, refer to {3.4 Terminal Specifications}.
- Control board <VFC66-Z>**  
 This is a control part of the inverter. A terminal block is located on the left side. For details of wiring, refer to {3.3.1 How to Connect Inverter Terminals} and {3.5.4 Electrical Wire Size on Control Board and PG Input Board}. For details of the terminal block, refer to {3.4 Terminal Specifications}. For how to replace the control board <VFC66-Z>, refer to {8.2 How to Replace Control Board}. The control board has different mounting methods depending on the model name. Check the board model name before replacing the board.
- Console board <SET66-Z>**  
 This is a console part of the inverter. It has switches for the LED and the operation keys.
- PG input board <PG66-Z> or various optional boards**  
 <PG66-Z> is used to connect a speed sensor (PG). A terminal block is located on the left side. Optional boards are used to add external input/output and communication functions.

## Chapter 3 How to Install and Connect Inverter

### 3.1 Surrounding Environment and How to Install It

#### 3.1.1 Installation Environment

Install the inverter in an environment below the overvoltage category III and below the pollution degree 2 defined by the IEC60664-1.

##### Overvoltage category

Overvoltage category	Equipment	Equipment overview
I	Secondary circuit	Equipment connecting to a circuit where any measures are taken to limit transient overvoltage to a lower level. It includes a protected electronic circuit.
II	Home electrical appliance and office machine	Equipment consuming energy supplied from a fixed wiring facility.
III	Electrical facility	Equipment in the fixed wiring facility which especially requires reliability and effectiveness.
IV	Power receiving	Equipment used for a service entrance.

##### Pollution degree

Pollution degree	Overview	Specific example
1	There is no pollution, or only dry and non-conductive pollution occurs. This type of pollution has no effect.	Clean room and others
2	Typically, only non-conductive pollution occurs. However, when a PDS (Power Drive System) is not running, temporary conductivity can be expected due to condensation.	Electrical equipment in an office and the control panel, and others
3	Conductive pollution, or dry and non-conductive pollution resulting in conductivity due to expected condensation occurs.	In a general factory and others
4	Pollution causes continuous conductivity due to conductive dust, rain, and snow.	Outdoor and others

#### 3.1.2 How to Install Inverter

##### ■ Requirements of where to install the inverter

Installation conditions of the inverter will greatly affect its life and reliability. Avoid installing it in the places listed below. Use it under the environmental conditions described in {Chapter 9 Standard Specifications}.

- (1) In a humid and dusty area or a place where water or oil drips, the insulation of circuits is deteriorated, which may reduce the life of parts.
- (2) Too high ambient temperature will cause the life of the main circuit capacitor or the cooling fan to be reduced.
- (3) In a place containing corrosive gas, connectors may have a loose connection, electrical wires may be disconnected, and parts may be damaged.
- (4) In a place having many vibrations, connectors may have a loose connection, electrical wires may be disconnected, and parts may be damaged.
- (5) When using the inverter in a place where ambient temperature is below 0 °C, use a heater, etc. to ensure

that it becomes 0 °C or higher at the start of the inverter. After it starts, when the temperature becomes 0 °C or higher due to its heat generation, there is no problem.

#### ■ Mounting protective device

As a protective device when a short-circuit causes an accident, be sure to connect a fuse on the input side of the inverter. Use a fuse described in {3.5.3 Electrical Wire Size of Main Circuit Wires}.

#### ■ Action after short-circuit

Dispose a short-circuited inverter in any circumstances without using it.

### CAUTION Installation

- Install the inverter on non-inflammables such as metal.  
Otherwise, a fire may occur.
- Do not put inflammables near the inverter.  
Otherwise, a fire may occur.
- A model over 22 kW is considered as a heavy material. Don't lift it by yourself. Otherwise, you may be injured.
- Do not hold the front cover when transporting the inverter.  
It may fall, which may result in injury.
- Install the inverter in a place which can support its weight.  
It may fall, which may result in injury.
- Do not install and operate the inverter which is damaged or does not have any parts.  
Otherwise, you may be injured.
- Do not install the inverter in an atmosphere which contains plasticizer such as halogen and DOP (phthalate ester).  
Otherwise, it may be damaged.

#### ■ Inverter installation requirements and heat radiation

To use the inverter, incorporate it into the control panel, etc. to meet the environmental conditions for installation.

### WARNING How to install inverter

- Install it correctly.  
Incorrect installation may result in a risk of electric shock or a fire.

#### ▪ Exhaust amount required for inverter loss and heat radiation

Inverter loss is represented as a ratio to the motor load capacity as follows:

2.2 to 37 kW: 5.0 %, 45 to 55 kW: 4 %, 75 to 90 kW: 3 %, 110 to 315 kW: 2.5 %

For example, when the motor load is 3.7 kW, the loss is 3.7 kW x 5.0 % = 185 W.

When heat generated from the inverter is forcibly exhausted outward by an exhaust fan installed on the control panel, necessary exhaust amount can be calculated in the following formula:

$$Q = q / \{ \rho \cdot C \cdot (T_o - T_a) \}$$

Where

Q: Exhaust flow (m<sup>3</sup>/s)

q: Amount of heat generated from the inverter (kW)

$\rho$ : Density (1.057 to 1.251 kg/ m<sup>3</sup>)

C: Specific heat (1.0 kJ/kg · °C)

To: Exhaust fan exit temperature (°C)

Ta: Control panel inlet temperature (°C)

When ambient temperature on the control panel is 40 °C, to ensure that exhaust temperature is below 50 °C, a difference between intake and exhaust should be 10 °C.

To exhaust a loss of 1 kW, an exhaust ability of about 0.1 m<sup>3</sup>/s is required.

- **Installation orientation and intake/exhaust direction**

Install the inverter vertically with a logo mark "VF66B" facing up. When it is installed sideways, ventilation is prevented, which may increase temperature. You should sufficiently consider a path of intake and exhaust. The cooling fan built in the inverter sucks air from the bottom and exhausts it to the top. To prevent a wiring duct, etc. from blocking up the vent, keep enough space.

- **Keeping cooling space**

To install the inverter and an optional direct-current reactor (DCL), keep cooling space.

When heat generation devices exist in the surrounding environment, place them so that they do not affect cooling of the inverter and others.

The operating temperatures of the inverter are 0 to 50 °C. To install it in the control panel, perform ventilation to ensure that the temperature in the board is below 50 °C. High ambient temperature will decrease reliability.

The figure below shows cooling space required for models below 7.5 kW. For models over 11 kW, keep the size twice as much as the dimensions described in the figure.

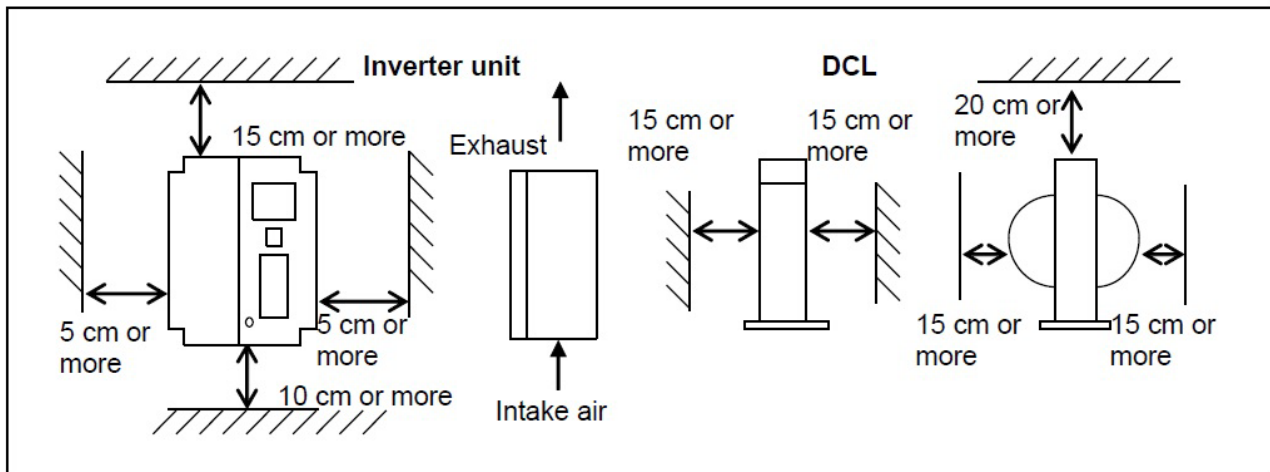

### Heat radiation and exhaust

- The DCL becomes hot. It may exceed 100 °C. Provide enough space to keep away from other devices.
- Make sure that heat generated from the inverter and the DCL is exhausted outward from the control panel. Note that exhaust from the inverter should not circulate in the control panel.
- When using a dynamic braking (DB) optional unit (VFDB2009), install a dynamic braking (DB) resistor outside from the control panel as much as possible.
- Avoid using the inverter in a seriously worse environment.

## 3.2 How to Open and Close Front Cover

### **WARNING** Opening and closing front cover

- Be sure to turn off the inverter when opening and closing the front cover. Otherwise, it may result in a risk of electric shock.

### 3.2.1 How to Open Front Cover

To work inside the inverter (such as connecting or wiring terminals, and maintenance/inspection), follow the steps below to open the front cover.

■ For models below 7.5 kW consisting of a resin chassis and front cover

#### 1. Use the Phillips screwdriver (M4) to loosen a mounting screw on the front cover.

- You do not have to remove the screw.

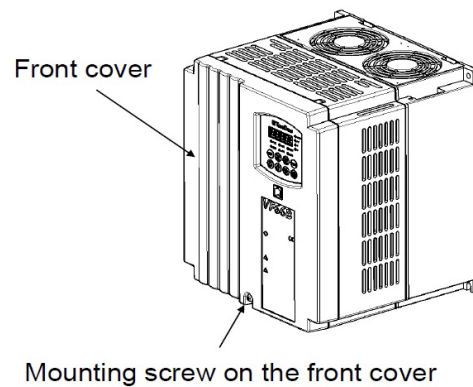

2. Lift the cover in the direction of the arrow (A) to the position shown in the figure, using two claws on the top of the front cover as supporting points.

3. Push the front cover in the direction of the arrow (B) and then remove the two claws on the front cover from the inverter main unit.

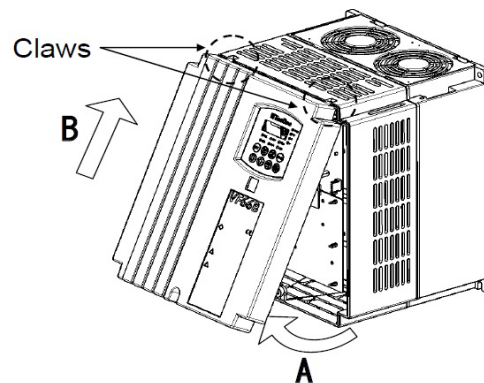

■ For models over 11 kW consisting of a sheet-metal chassis and front cover  
Remove the sheet-metal front cover and the resin control part cover.

1. Use the Phillips screwdriver (M4) to remove the mounting screws at the top of the front cover.

2. Loosen the screws at the bottom of it.

3. Remove the front cover from the main unit.

- The number of mounting screws at the top and bottom of the front cover depends on the model. Refer to the figure below.

VF66B-1122, 1522, 2222, 3022, 3722, 4522, 5522  
1144, 1544, 2244, 3044, 3744, 4544, 5544

You can remove the cover by only loosening the screws at the bottom.

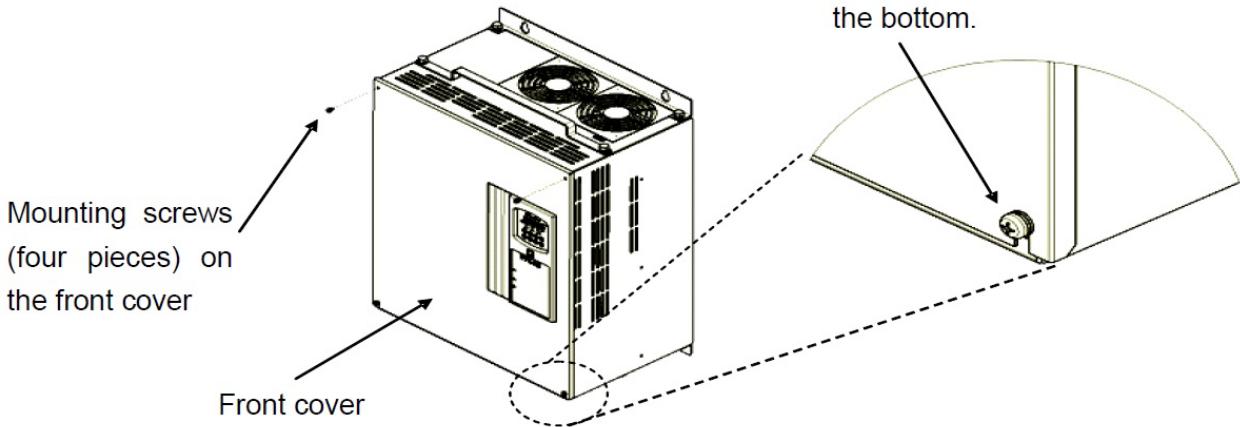

VF66B-7522, 9022(15044, 18044)  
7544, 11044, 16044

You can remove the front cover by only loosening the screws at the bottom of each front cover.

Mounting screws on the front cover  
(Upper cover: five pieces)  
(Lower cover: five pieces)

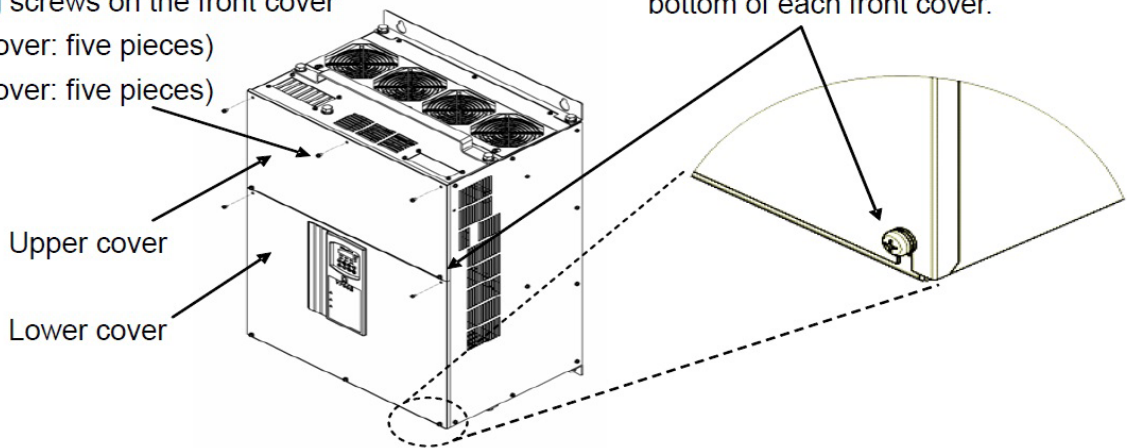

VF66B- 20044, 25044, 31544  
(40044 - 100044)

Converter part

Mounting screws on the front cover  
(Upper cover: four pieces)  
(Lower cover: four pieces)

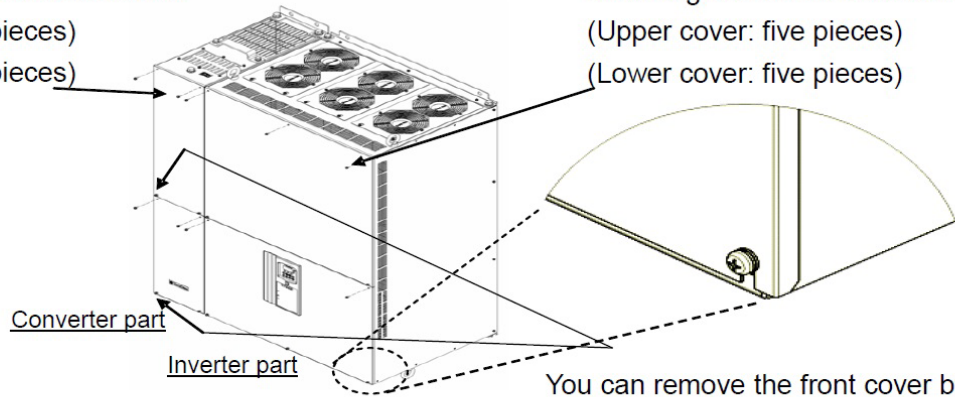

Inverter part

Mounting screws on the front cover  
(Upper cover: five pieces)  
(Lower cover: five pieces)

You can remove the front cover by only loosening the screws at the bottom of each front cover.

**4. When the control part cover is vibration resistant, use the Phillips screwdriver (M4) to remove two mounting screws of the control part cover.**

- When it is not vibration resistant, it does not have mounting screws.

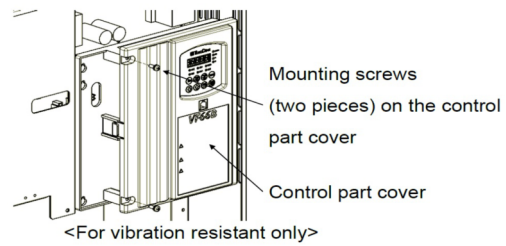

**5. While holding the lock part of the control part cover with your thumb, pull it toward and remove it, using the two claws on the right side as supporting points.**

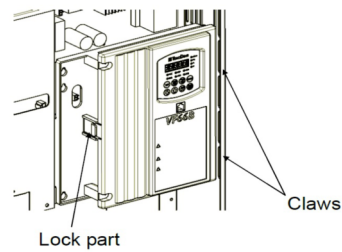

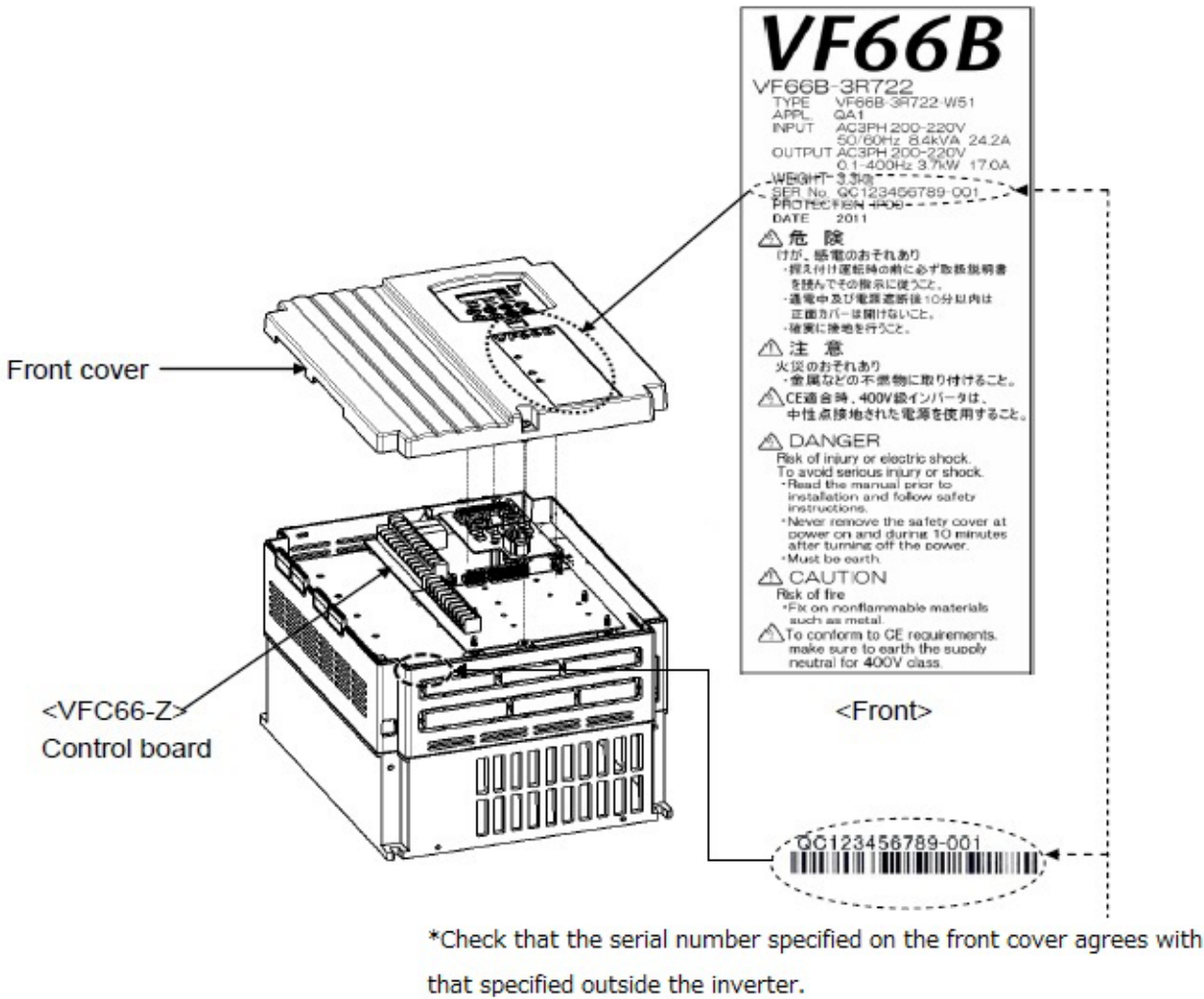

**CAUTION** Opening and closing front cover

- The inverter model below 7.5 kW has a resin chassis.  
Applying excessive force will cause the cover to be damaged.

## **WARNING** Notes for replacing parts

- Do not disassemble the inverter unreasonably.
- After disassembling it, check that any part is assembled correctly.  
Incorrect assembly may result in a risk of a fire.
- In particular, if a flat cable is not inserted correctly, the control circuit may not work properly.
- Make sure that screws are tightened.

### 3.2.2 How to Close Front Cover

Follow the steps below to close the front cover of the inverter.

When closing the front cover, ensure that the serial number described in the main unit matches the one described on the front cover. For how to check the serial number, refer to {3.2.1 How to Open Front Cover}.

- For models below 7.5 kW consisting of a resin chassis and front cover

## **CAUTION** Tightening screws

- Tighten screws into screw holes of the front cover within a tightening torque of 1.4 N·m.  
Tightening them in a tightening torque of over 1.4 N·m can the resin front cover to be damaged.

**1. Insert the two claws on the top of the front cover into the sockets of the inverter main unit.**

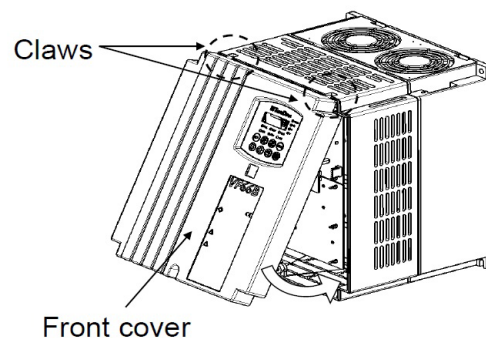

**2. Install the front cover into the main unit.**

**3. Use the Phillips screwdriver (M4) to tighten a mounting screw of the front cover.**

- Tighten it within a tightening torque of 1.4 N·m.

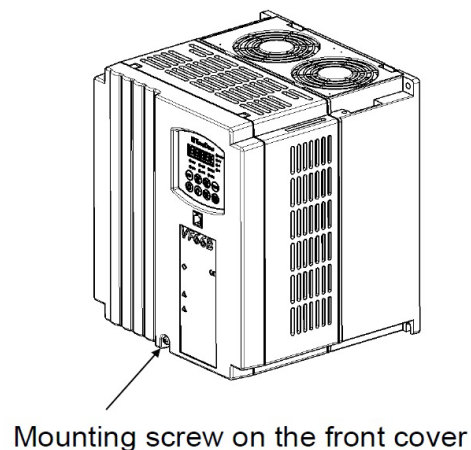

■ For models over 11 kW consisting of a sheet-metal chassis and front cover  
Install the resin control part cover and the sheet-metal front cover.

**1. Insert the two claws on the right side of the control part cover into the sockets of the inverter main unit.**

**2. Push them until a lock clicks.**

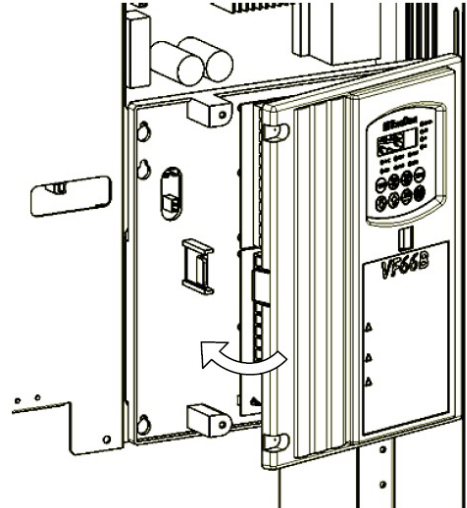

**3. When the control part cover is vibration resistant, use the Phillips screwdriver (M4) to tighten the two mounting screws of the control part cover.**

- Tighten it within a tightening torque of 1.4 N·m.
- When it is not vibration resistant, it does not have mounting screws.

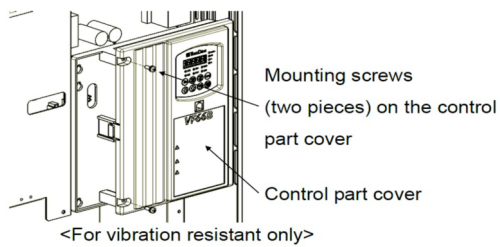

**4. Use the Phillips screwdriver (M4) to tighten the mounting screws of the front cover.**

- Tighten it within a tightening torque of 1.5 N·m.
- The number of mounting screws of the front cover depends on the model. Refer to the figure below.

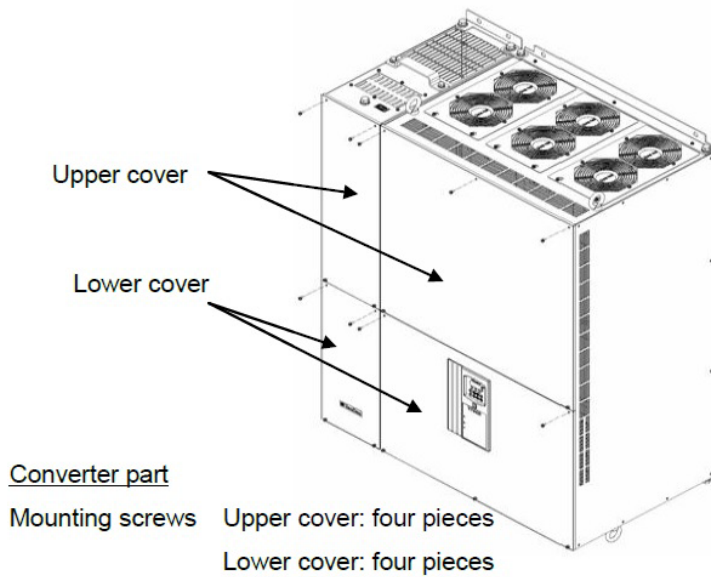
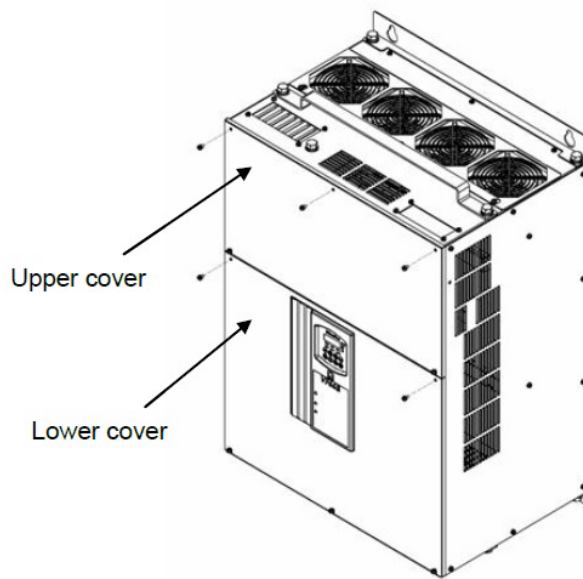
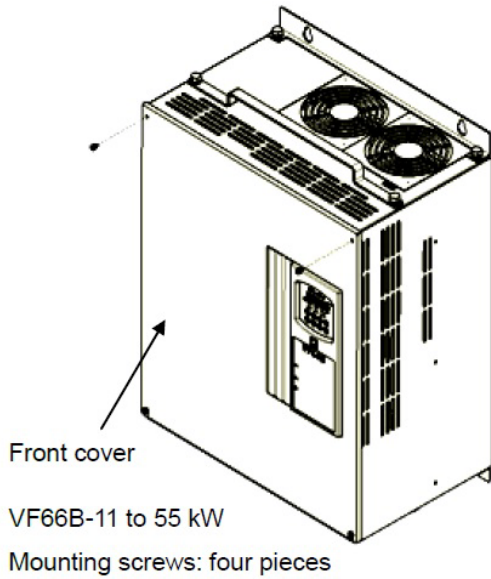

VF66B—20044,25044,31544  
Inverter part  
Mounting screws Upper cover: five pieces  
Lower cover: five pieces

### 3.3 How to Connect Inverter

#### 3.3.1 How to Connect Inverter Terminals

The figure below shows the connection diagram of the inverter terminals.

For a connection of the speed sensor (PG), refer to {3.3.2 How to Connect Speed Sensor and PG Input Board}.

For specifications of each terminal, refer to {3.4 Terminal Specifications}.

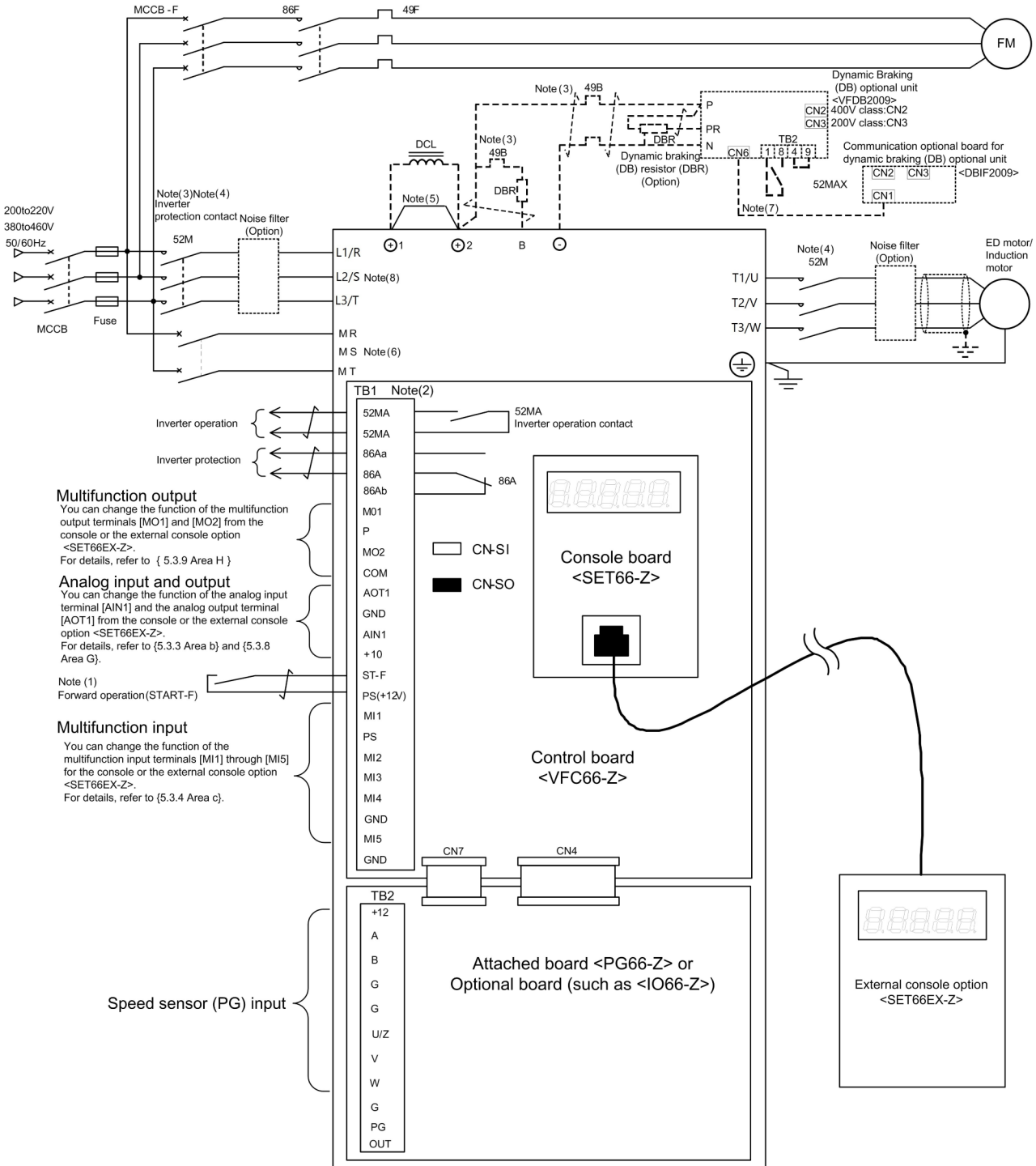

- (1) In the factory default, a control input terminal [ST-F] and multifunction input terminals [MI1] through [MI5] are set to PS common input (source input).  
When changing them to GND common input (sink input), remove a jumper socket on the control board <VFC66-Z> from [CN\_SO] and then attach it to [CN\_SI].
- (2) Never connect [GND] and [COM] (terminals of the multifunction input/output terminal and the analog input/output terminal) to the ground.
- (3) When a thermal relay of the dynamic braking (DB) resistor starts, the inverter input power supply should be blocked.
- (4) Install a main circuit contactor (52M) depending on your environmental needs.  
When installing the main circuit contactor (52M) on the input side of the inverter, turn off the inverter input power supply and then wait for over ten minutes before turning it on again.  
In principle, does not turn on or off the main circuit contactor between the inverter and the motor while the inverter is running.  
If the main circuit contactor is turned on or off while the inverter is running, overcurrent applied to the inverter, and cause a failure.  
After stopping the inverter, turn on or off the main circuit contactor.  
However, it is except when you use the constant output (power constant) area and want to immediately stop output voltage with the operation turned off, or you need to immediately stop the inverter output such as emergency stop.  
For notice of using the constant output [power constant] area, refer to {5.3.3 Area b (Setting Area for Operation Mode and Operation Sequence)}.
- (5) When the direct-current reactor (DCL) is not connected, the direct-current terminals [+1] and [+2] are short circuited.
- (6) Control power supply terminals are provided for models over 11 kW.  
When the control power supply terminals [MR] and [MT] are used in parallel models (<15022> through <18022>, <40044> through <100044>), power should be supplied to not only a master unit but a slave unit.
- (7) When the control board <VFC66-Z> communicates with the dynamic braking (DB) optional unit <VFDB2009>, a communication optional board <DBIF2009-Z> for the dynamic braking (DB) optional unit is used.  
For details, refer to another manual "VFDB2009 Instruction Manual."
- (8) Supply electric power from the same power supply about each unit of a parallel models (<15022> through <18022>, <40044> through <100044>).

### 3.3.2 How to Connect Speed Sensor and PG Input Board

To use the speed sensor (PG), follow the steps below to connect the PG input board <PG66-Z> to the PG.

The figure below shows the connection diagram for the ED motor. For the induction motor, connect PG input terminals [+12], [A], [B], and [G] only.

To connect the PG for the ED motor, an optional straight plug <MS3106B-20-29S> (manufactured by Japan Aviation Electronics Industry, Limited) and a cable clamp <MS3057-12A> (manufactured by Japan Aviation Electronics Industry, Limited) are required.

### Setting for using speed sensor (PG)

To perform drive with the speed sensor (PG), you should change the setting value of the PG\_selection <A-10> to "1" or "2."



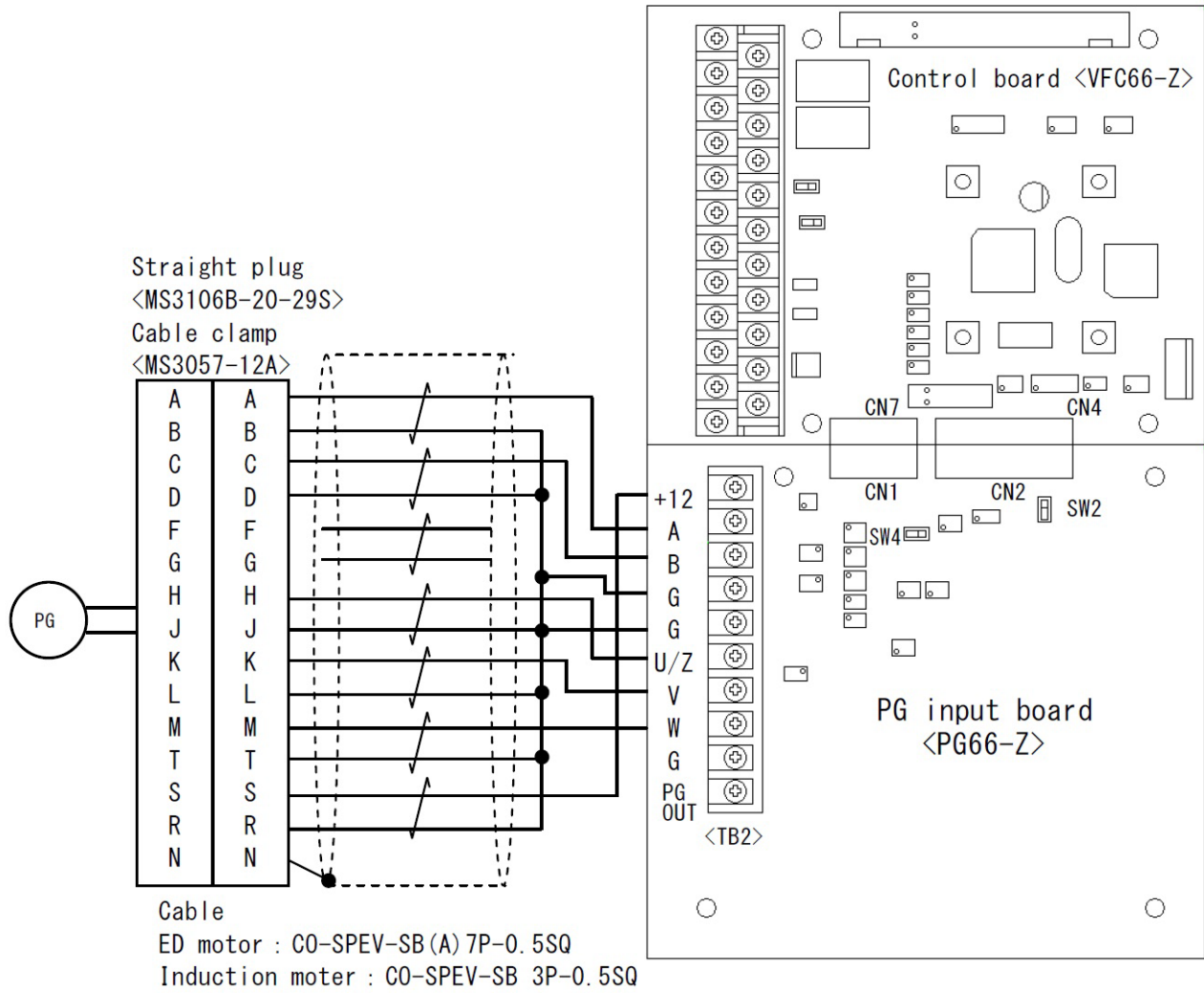

For details of how to change parameters, refer to {4.1.3 Changing Parameter Settings}. For details of the PG\_selection <A-10>, refer to {5.3.2 Area A}.

1. Turn off the inverter.
2. Open the front cover.
  - For how to open the front cover, refer to {3.2.1 How to Open Front Cover}.
  - Use the Phillips screwdriver (M4).
3. When using the motor with the speed sensor (PG), turn on the switch [SW2] on the <PG66-Z> with a pair of tweezers or a tool whose tip is very short in length (about 0.8 mm).
4. Connect terminals of the <PG66-Z> to corresponding ones of the PG.
  - Use the Phillips screwdriver (M3).
  - Use a special twist shielded wire for cables to be connected.  
The recommended cables are as follows:  
ED motor: CO-SPEV-SB(A) 7P-0.5SQ  
Induction motor: CO-SPEV-SB 3P-0.5SQ
5. Close the front cover.



### 3.4 Terminal Specifications

#### Main circuit

Terminal number	Purpose	Descriptions
L1/R, L2/S, L3/T	Alternating-current power supply input	Connect to the alternating-current power supply
T1/U, T2/V, T3/W	Inverter output	Connect the three-phase alternating-current motor
 +1	DCL connection	Connect to the DCL When no DCL is used, the direct-current terminals [+1] and [+2] are short circuited.
 +2	<ul style="list-style-type: none"> <li>▪ DCL connection</li> <li>▪ Connect the dynamic braking (DB) resistor</li> <li>▪ Connect a positive side terminal when using a sine wave converter</li> </ul>	<ul style="list-style-type: none"> <li>▪ Terminal for connecting the dynamic braking (DB) resistor</li> <li>▪ Connect a positive side terminal of the direct-current power supply when using the sine wave converter</li> </ul>
B	Connect the dynamic braking (DB) resistor	Collector terminal for the built-in dynamic braking (DB) transistor (It is provided for models below 22 kW)
 -	<ul style="list-style-type: none"> <li>▪ Connect the dynamic braking (DB) optional unit</li> <li>▪ Connect a negative side terminal when using the sine wave converter</li> </ul>	<ul style="list-style-type: none"> <li>▪ Connecting terminal to a terminal "N" of the dynamic braking (DB) optional unit</li> <li>▪ Connect a negative side terminal of the direct-current power supply when using the sine wave converter</li> </ul>
	Protective earth terminal	[Caution] Be sure to connect it to the ground. When using a noise filter, connect it to a protective earth terminal of the filter.
MR, MS, MT	Control power supply terminal	<ul style="list-style-type: none"> <li>▪ They are provided for models over 11 kW and are used to supply power to only control circuits.</li> <li>▪ Connect the alternating-current power supply between [MR] and [MT], not [MS].</li> </ul> <p>[Caution] When they are used in parallel models (&lt;15022&gt; through &lt;18022&gt;, &lt;40044&gt; through &lt;100044&gt;), power should be supplied to not only the master unit but the slave unit.</p>

Terminal block &lt;TB1&gt; on the control board &lt;VFC66-Z&gt;

Terminal number	Purpose	Descriptions
52MA	Operation contact	It turns on while the inverter operates. Contact rating 230 VAC/30 VDC, 0.5 A
86A	Protection contact	It turns on while the inverter is in the protection mode. Contact rating 230 VAC/30 VDC, 0.5 A
MO1	Multifunction output terminal (1)	<b>Multifunction output</b> <ul style="list-style-type: none"> <li>Maximum voltage 24 VDC, maximum output current 20 mA</li> <li>The multifunction output terminal outputs signals depending on the operation condition.</li> </ul> For details, refer to {5.3.9 Area H}. <ul style="list-style-type: none"> <li>Connect a P terminal to an external power supply (DC)</li> </ul> <b>■ Initial state</b> <ul style="list-style-type: none"> <li>Multifunction output terminal (1): Output signals when the frequency or the speed reach their command</li> <li>Multifunction output terminal (2): Output signals when the inverter detects the specified frequency or speed</li> </ul>
P	P terminal	
MO2	Multifunction output terminal (2)	
COM	COM terminal	
AOT1	Analog output (1) terminal	<b>Analog input and output</b> <ul style="list-style-type: none"> <li>In the analog output terminal [AOT1], you can change 0 to <math>\pm 10</math> V output and 6F (frequency) output. Its maximum output current is 1 mA.</li> <li>In the analog input terminal [AIN1], you can switch the input range to 0 through <math>\pm 10</math> V or 0 through 10 V by changing the setting data.</li> <li>Also, you can switch to 4 to 20 mA input by setting the SW1 to "ON."</li> <li>Use 10 k<math>\Omega</math> when performing a frequency or speed command depending on volume.</li> </ul> <b>■ Initial state</b> <ul style="list-style-type: none"> <li>Analog output terminal [AOT1]: Output current from the inverter as "5 V/rated inverter current"</li> <li>Analog input terminal [AIN1]: 0 to 10 V input</li> </ul> [Caution] Do not connect the terminal [GND] to the protective earth terminal.
GND	GND terminal	
AIN1	Analog input (1) terminal	
+10	+10 V output	Output +10 V direct-current voltage
ST-F	Forward operation	Input terminal for a forward operation signal
PS	+12 V output	Output +12 V direct-current voltage
MI1	Multifunction input terminal (1)	<b>Multifunction input</b> <ul style="list-style-type: none"> <li>Maximum input voltage 24 VDC, maximum input current 3 mA</li> <li>Like from the console, you can operate the inverter by inputting a signal into the multifunction input terminal.</li> </ul> For details, refer to {5.3.4 Area c}. <b>■ Initial state</b> <ul style="list-style-type: none"> <li>Multifunction input terminal (1): Start command (reverse)</li> <li>Multifunction input terminal (2): JOG command (forward)</li> <li>Multifunction input terminal (3): JOG command (reverse)</li> <li>Multifunction input terminal (4): Emergency stop (Normally open) signal</li> <li>Multifunction input terminal (5): Protection reset</li> </ul> [Caution] Do not connect the terminal [GND] to the protective earth terminal.
MI2	Multifunction input terminal (2)	
MI3	Multifunction input terminal (3)	
MI4	Multifunction input terminal (4)	
GND	GND terminal	
MI5	Multifunction input terminal (5)	

## Terminal block &lt;TB2&gt; on the PG input board &lt;PG66-Z&gt;

Terminal number	Purpose	Descriptions
+12	+12 V power supply terminal	Output +12 V direct-current voltage
G	GND terminal	[Caution] Do not connect the terminal [G] to the protective earth terminal.
A	PG input terminal	Input A, B, U/Z, V, and W signals of the 12 V power supply PG (complementary output)
B		
U/Z		
V		
W		
PGOUT		

Terminal layout of main circuit terminals

<p>●VF66B-2R222 VF66B-3R722 VF66B-2R244 VF66B-3R744</p>	<p>●VF66B-5R522 VF66B-7R522 VF66B-5R544 VF66B-7R544</p>
<p>●VF66B-1122 VF66B-1522 VF66B-1144 VF66B-1544</p>	<p>●VF66B-2222 VF66B-2244</p>
<p>●VF66B-3022</p>	<p>●VF66B-3044</p>
<p>●VF66B-3722</p>	<p>●VF66B-3744</p>

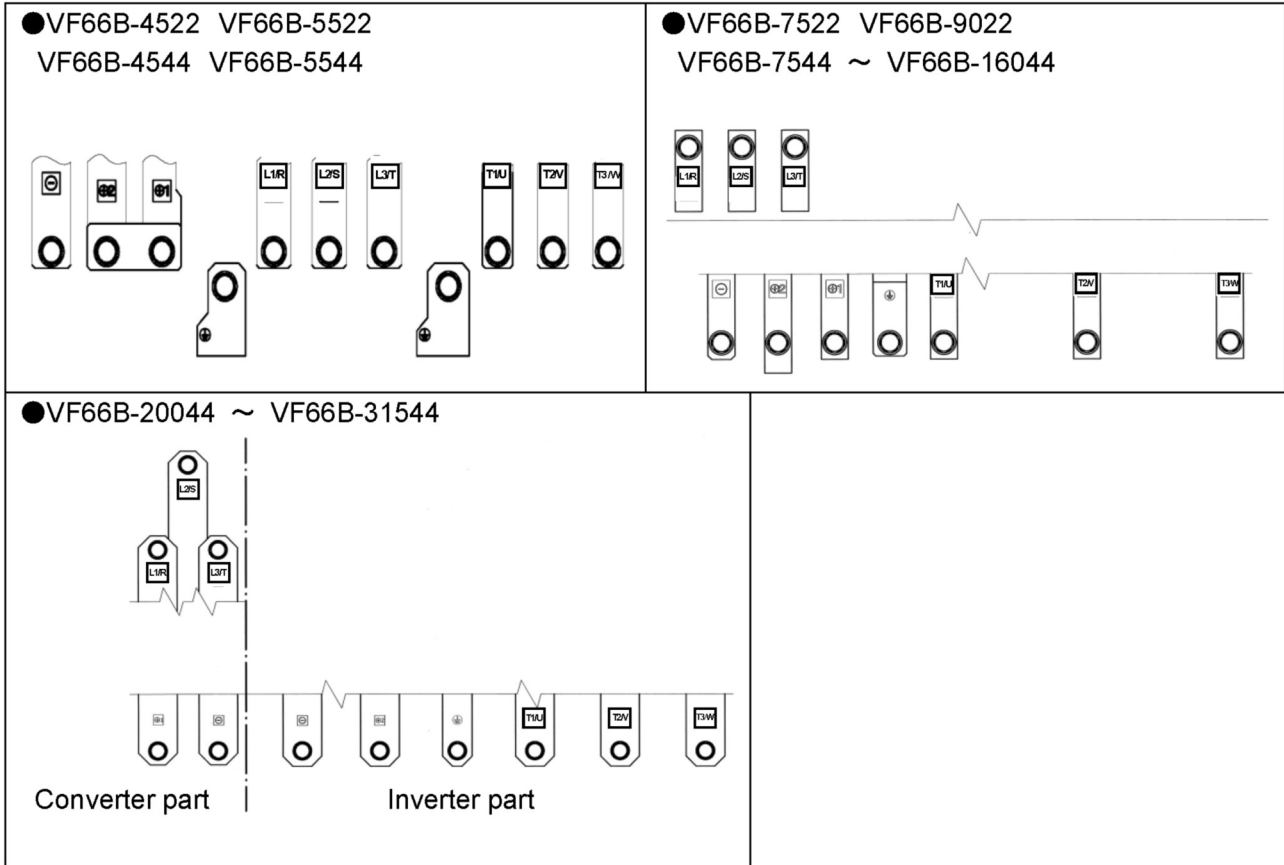

## 3.5 Notes for Wiring and Electrical Wire Size

### 3.5.1 Notes for Wiring

- (1) Input the specified voltage into the input terminals [L1/R, L2/S, L3/T] of the inverter.
  - If you input 400 V into the 200 V class inverter, it will be damaged.
- (2) IGBT is used for elements of the inverter, and the inverter operates at high frequency. Therefore, noise frequently occurs. Consider the following points for wiring:
  - Keep main circuit wires away from a control signal wire. When placing them in parallel, keep a distance of 30 cm or longer between them.
  - When crossing them, ensure that they are crossed at right angles.
  - It is recommended that the main circuit wire should be contained into a metal pipe as a noise measure for other facilities.

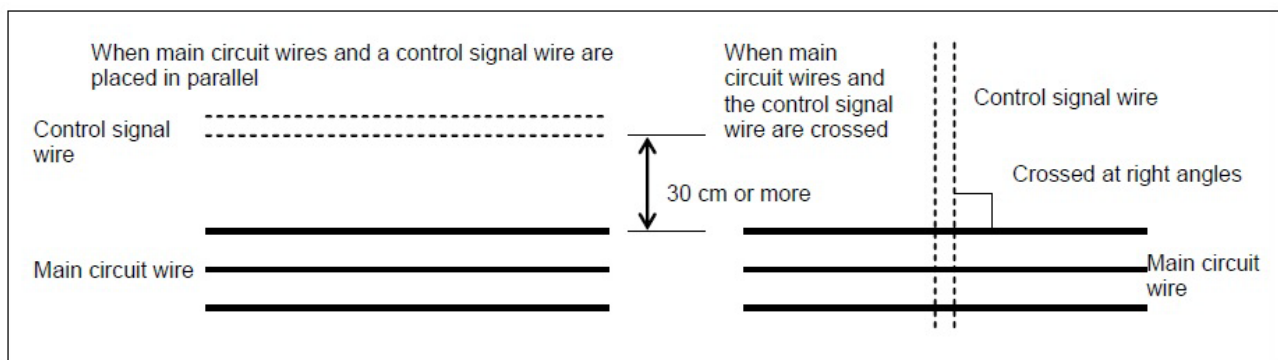

- (3) To prevent noise contamination, use a shielded wire or a twist shielded wire for the control signal wire.
- (4) When setting speed outside from the control panel  
Contain the signal wire into the metal pipe to install it.
- (5) When using the shielded wire for output wiring  
When the wiring has 300 m or longer in length  
When the inverter is operated with the DC brake, a resonance phenomenon occurs due to floating capacitance and source inductance, both of which are generated to the ground by the inverter output electrical wire. It may cause the inverter to be damaged or not to work properly.
  - Contact us.
- (6) The wiring of the 400 V class inverter has 100 m or longer in length  
Due to the wiring, surge voltage generated in the motor terminal may cause the motor insulation to be deteriorated.  
Take one of the following measures:
  - Use the motor with enhanced insulation.
  - Connect a surge voltage suppression filter on the inverter side.

### 3.5.2 Electrical Corrosion Measures

When the inverter drives the motor, high-frequency common mode voltage is generated. If impedance between the motor or machine and the ground is high, voltage is applied to both sides of a bearing, which may cause electrical corrosion. To avoid this, take the following measures:

- (1) Be sure to connect an inverter plate and a machine surface plate to the ground.

Be sure to connect the ground wire between the inverter plate and the motor.

- (2) Put the motor and the machine on the same surface plate.

When the surface plate of the motor is isolated from that of the machine as shown in the figure below, axis current is applied from the machine bearing to a machine frame through a motor stator, a rotator, and a shaft. It may cause electrical corrosion in the machine bearing.

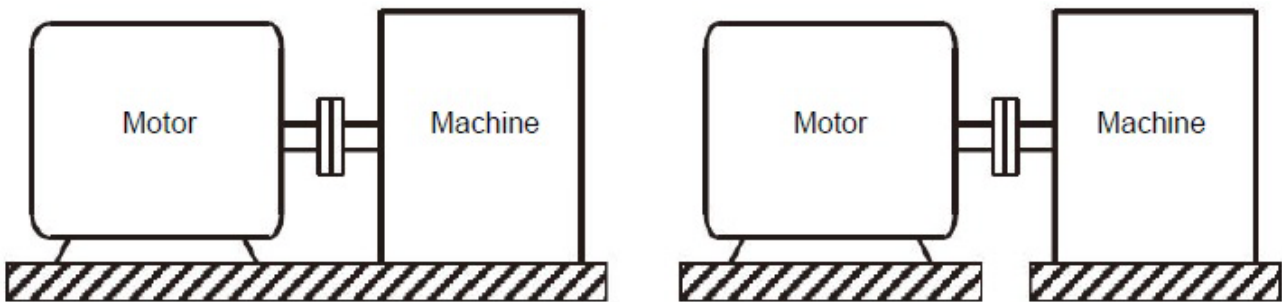

- (3) When the motor and the machine cannot be put on the same surface plate, using insulation coupling for a connection between the motor and the machine will be effective.
- (4) For belt driving, there is no problem on the machine side. Connect the inverter plate and the machine surface plate to the ground.
- (5) For a long distance between the inverter plate and the motor, install an output filter for inverter output to reduce high-frequency components.

### 3.5.3 Input / Output Devices and Electrical Wire Size of Main Circuit Wires

The electrical wire size of main circuit wires depends on the inverter model.

See the table below to use appropriate electrical wires for connection.

■ 200 V class

Applied motor capacity <sup>(2)</sup>	Wiring circuit breaker (MCCB) <sup>(3)</sup>	Leakage circuit breaker (ELCB) <sup>(3)</sup>	Fuse model <sup>(4)</sup>	Main circuit contactor <sup>(5)</sup>		Wire size [mm <sup>2</sup> ] <sup>(10)</sup> (Upper position: inside the board, lower position: outside the board)			
						Inverter model	Rated current	Input side	Output side
2.2kW	NF32-SV 15A	NV32-SV 15A	CR2LS-20/UL	S-T12	S-T10	2	2	2	3.5
2R222	BW32SAG 15A	EW32SAG 15A	20A	SC-0	SC-03	3.5	3.5	3.5	[AWG12]
3.7kW	NF32-SV 30A	NV32-SV 30A	CR2LS-30/UL	S-T20	S-T20	3.5	3.5	5.5	5.5
3R722	BW32SAG 30A	EW32SAG 30A	30A	SC-N1	SC-4-0	3.5	3.5	5.5	[AWG10]
5.5kW	NF63-SV 40A	NV63-SV 40A	CR2LS-50/UL	S-T32	S-T25	8	5.5	8	5.5
5R522	BW50SAG 40A	EW50SAG 40A	50A	SC-N2	SC-N1	8	5.5	8	[AWG10]
7.5kW	NF63-SV 50A	NV63-SV 50A	CR2LS-75/UL	S-T50	S-T35	8	8	14	8
7R522	BW50SAG 50A	EW50SAG 50A	75A	SC-N2S	SC-N2	8	8	14	[AWG8]
11kW	NF125- SEV 75A	NV125- SEV 75A	CR2LS-100/UL	S-T65	S-T50	14	8	14	8
1122	BW125JAG 75A	EW125JAG 75A	100A	SC-N3	SC-N2S	14	14	14	[AWG8]
15kW	NF125- SEV 100A	NV125- SEV 100A	CR2L-150/UL	S-T80	S-T65	22	14	22	14
1522	BW125JAG 100A	EW125JAG 100A	150A	SC-N4	SC-N3	22	22	22	[AWG6]
22kW	NF250- SEV 150A	NV250- SEV 150A	CR2L-150/UL	S-N125	S-T100	38	22	38	14
2222	BW250JAG 150A	EW250JAG 150A	150A	SC-N6	SC-N5	38	38	38	[AWG6]
30kW	NF250- SEV 175A	NV250- SEV 175A	CR2L-260/UL	S-N150	S-N125	50	38	60	22
3022	BW250JAG 200A	EW250JAG 200A	260A	SC-N7	SC-N6	60	38	60	[AWG4]

Applied motor capacity <sup>(2)</sup>	Wiring circuit breaker (MCCB) <sup>(3)</sup>	Leakage circuit breaker (ELCB) <sup>(3)</sup>	Fuse model <sup>(4)</sup>	Main circuit contactor <sup>(5)</sup>		Wire size [mm <sup>2</sup> ] <sup>(10)</sup> (Upper position: inside the board, lower position: outside the board)			
				Rated current	Input side	Output side	Input side <sup>(6)</sup>	Output side <sup>(6)</sup>	DC input/DCL <sup>(6)</sup>
37kW	NF250-SEV 225A	NV250-SEV 225A	CR2L-300/UL	S-N220	S-N150	60	50	80	22
3722	BW250JAG 225A	EW250JAG 225A	300A	SC-N8	SC-N7	60	60	100	[AWG4]
45kW	NF400-SEW 300A	NV400-SEW 300A	CR2L-325/UL	S-N220	S-N220	80	60	125	22
4522	BW400SAG 300A	EW400SAG 300A	325A	SC-N10	SC-N8	100	100	150	[AWG4]
55kW	NF400-SEW 350A	NV400-SEW 350A	CR2L-400/UL	S-N300	S-N220	125	80	200 <sup>(11)</sup>	30
5522	BW400SAG 350A	EW400SAG 350A	400A	SC-N11	SC-N10	150	150	200 <sup>(11)</sup>	[AWG2]
75kW	NF400-SEW 350A	NV400-SEW 350A	CR2L-450/UL	S-N400	S-N300	150	150	200	30
7522	BW400SAG 350A	EW400SAG 350A	450A	SC-N12	SC-N11	150	150	200	[AWG2]
90kW	NF630-SEW 500A	NV630-SEW 500A	CR2L-500/UL	S-N400	S-N400	200 <sup>(11)</sup> (150)	200(150)	250	38
9022	BW630RAG 500A	EW630RAG 500A	500A	SC-N12	SC-N12	200 <sup>(11)</sup>	200	150 × 2	[AWG2]
150kW	NF800-SEW 700A		CR2L-450/UL × 2			150 × 2	150 × 2	200 × 2	30 × 2
15022	BW800RAG 700A		450A × 2			150 × 2	150 × 2	200 × 2	[AWG2] × 2
180kW	NF1000-SEW 900A		CR2L-500/UL × 2			200 × 2 (150 × 2)	200 × 2 (150 × 2)	250 × 2	38 × 2
18022	SA1003E 900A		500A × 2			200 × 2	200 × 2	150 × 2 × 2	[AWG2] × 2

## ■ 400 V class

Applied motor capacity <sup>(2)</sup>	Wiring circuit breaker (MCCB) <sup>(3)</sup>	Leakage circuit breaker (ELCB) <sup>(3)</sup>	Fuse model <sup>(4)</sup>	Main circuit contactor <sup>(5)</sup>		Wire size [mm <sup>2</sup> ] <sup>(10)</sup> (Upper position: inside the board, lower position: outside the board)			
				Rated current	Input side	Output side	Input side <sup>(6)</sup>	Output side <sup>(6)</sup>	DC input/DCL <sup>(6)</sup>
2.2kW	NF32-SV 10A	NV32-SV 10A	660GH-16	S-T10	S-T10	2	2	2	2
2R244	BW32SAG 10A	EW32SAG 10A	16A	SC-03	SC-03	2	2	2	[AWG14]
3.7kW	NF32-SV 15A	NV32-SV 15A	660GH-16	S-T20	S-T20	2	2	2	2
3R744	BW32SAG 15A	EW32SAG 15A	16A	SC-4-0	SC-4-0	2	2	2	[AWG14]
5.5kW	NF32-SV 20A	NV32-SV 20A	660GH-25	S-T20	S-T20	3.5	2	3.5	5.5
5R544	BW32SAG 20A	EW32SAG 20A	25A	SC-4-1	SC-4-0	3.5	3.5	3.5	[AWG10]
7.5kW	NF32-SV 30A	NV32-SV 30A	660GH-32	S-T25	S-T20	3.5	3.5	5.5	5.5
7R544	BW32SAG 30A	EW32SAG 30A	32A	SC-N1	SC-4-1	3.5	3.5	5.5	[AWG10]
11kW	NF63-SV 40A	NV63-SV 40A	660GH-40	S-T32	S-T25	5.5	5.5	8	5.5
1144	BW50SAG 40A	EW50SAG 40A	40A	SC-N2	SC-N1	5.5	5.5	8	[AWG10]
15kW	NF63-SV 50A	NV63-SV 50A	660GH-63	S-T50	S-T35	8	8	8	5.5
1544	BW50SAG 50A	EW50SAG 50A	63A	SC-N2S	SC-N2	8	8	8	[AWG10]
22kW	NF125-SEV 75A	NV125-SEV 75A	660GH-80	S-T65	S-T50	14	8	14	8
2244	BW125JAG 75A	EW125JAG 75A	80A	SC-N3	SC-N2S	14	14	14	[AWG8]
30kW	NF125-SEV 100A	NV125-SEV 100A	660GH-125	S-T80	S-T65	22	14	38	14
3044	BW125JAG 100A	EW125JAG 100A	125A	SC-N4	SC-N3	22	22	38	[AWG6]
37kW	NF125-SEV 125A	NV125-SEV 125A	660GH-160	S-N125	S-T80	38	22	38	14
3744	BW250JAG 125A	EW250JAG 125A	160A	SC-N6	SC-N4	38	22	38	[AWG6]

Applied motor capacity <sup>(2)</sup>	Wiring circuit breaker (MCCB) <sup>(3)</sup>	Leakage circuit breaker (ELCB) <sup>(3)</sup>	Fuse model <sup>(4)</sup>	Main circuit contactor <sup>(5)</sup>		Wire size [mm <sup>2</sup> ] <sup>(10)</sup> (Upper position: inside the board, lower position: outside the board)			
						Inverter model	Rated current	Input side	Output side
45kW	NF250-SEV 150A	NV250-SEV 150A	660GH-200	S-N125	S-T100	38	22	50	14
4544	BW250JAG 150A	EW250JAG 150A	200A	SC-N7	SC-N6	38	22	60	[AWG6]
55kW	NF250-SEV 175A	NV250-SEV 175A	660GH-200	S-N150	S-N125	50	30	60	14
5544	BW250JAG 175A	EW250JAG 175A	200A	SC-N7	SC-N6	60	38	60	[AWG6]
75kW	NF250-SEV 200A	NV250-SEV 200A	660GH-250	S-N180	S-N150	60	50	80	22
7544	BW250JAG 200A	EW250JAG 200A	250A	SC-N8	SC-N7	60	60	100	[AWG4]
110kW	NF400-SEW 300A	NV400-SEW 300A	660GH-315	S-N300	S-N220	100 (80)	80	125(100)	22
11044	BW400SAG 300A	EW400SAG 300A	315A	SC-N11	SC-N10	100	100	150(100)	[AWG4]
160kW	NF400-SEW 400A	NV400-SEW 400A	660GH-250 × 2	S-N400	S-N300	200 <sup>(11)</sup> (150)	150	250(200)	38
16044	BW400SAG 400A	EW400SAG 400A	250A × 2	SC-N12	SC-N11	200 <sup>(11)</sup>	200	250(200)	[AWG2]
200kW	NF630-SW 500A	NV630-SW 500A	660GH-315 × 2	S-N600	S-N400	250(200)	200	125 × 2 (200)	50
20044	BW630RAG 500A	EW630RAG 500A	315A × 2	SC-N14	SC-N12	250	250	250	[AWG1/0]
250kW	NF630-SW 600A	NV630-SW 600A	660GH-200 × 4	S-N600	S-N600	125 × 2 (250)	250	200 × 2 (250)	60
25044	BW630RAG 600A	EW630RAG 600A	200A × 4	SC-N14	SC-N14	150 × 2	150 × 2	200 × 2	[AWG1/0]
315kW	NF800-SEW 800A	NV800-SEW 800A	660GH-250 × 4	S-N800	S-N600	200 × 2 (150 × 2)	150 × 2	250 × 2 (150 × 2)	80
31544	BW800RAG 800A	EW800RAG 800A	250A × 4	SC-N16	SC-N14	200 × 2 (150 × 2)	150 × 2	250 × 2 (150 × 2)	[AWG2/0]

Applied motor capacity <sup>(2)</sup>	Wiring circuit breaker (MCCB) <sup>(3)</sup>	Leakage circuit breaker (ELCB) <sup>(3)</sup>	Fuse model <sup>(4)</sup>	Main circuit contactor <sup>(5)</sup>		Wire size [mm <sup>2</sup> ] <sup>(10)</sup> (Upper position: inside the board, lower position: outside the board)			
			Rated current	Input side	Output side	Input side <sup>(6)</sup>	Output side <sup>(6)</sup>	DC input/DCL <sup>(6)</sup>	Ground wire <sup>(9)</sup>
400kW	NF1000-SEW 1000A		660GH-315 × 4			250 × 2 (200 × 2)	200 × 2	125 × 2 × 2 (200 × 2)	50 × 2
40044	SA1003E 1000A		315A × 4			250 × 2	250 × 2	250 × 2	[AWG1/0] × 2
500kW	NF1250-SEW 1250A		660GH-200 × 8			125 × 2 × 2 (250 × 2)	250 × 2	200 × 2 × 2 (250 × 2)	60 × 2
50044	SA1203E 1200A		200A × 8			150 × 2 × 2	150 × 2 × 2	200 × 2 × 2	[AWG1/0] × 2
600kW	NF1600-SEW 1500A		660GH-315 × 6			250 × 3 (200 × 3)	200 × 3	125 × 2 × 3 (200 × 3)	50 × 3
60044	SA1603E 1600A		315A × 6			250 × 3	250 × 3	250 × 3	[AWG1/0] × 3
750kW	NF2000-S 2000A		660GH-200 × 12			125 × 2 × 3 (250 × 3)	250 × 3	200 × 2 × 3 (250 × 3)	60 × 3
75044	SA2003E 1800A		200A × 12			150 × 2 × 3	150 × 2 × 3	200 × 2 × 3	[AWG1/0] × 3
1000kW	NF2500-S 2500A		660GH-200 × 16			125 × 2 × 4 (250 × 4)	250 × 4	200 × 2 × 4 (250 × 4)	60 × 4
100044	SA2503E 2500A		200A × 16			150 × 2 × 4	150 × 2 × 4	200 × 2 × 4	[AWG1/0] × 4

(1) This table is based on the input voltage of 200 VAC for the 200 V class and 380 VAC for the 400 V class inverter.

(2) The applied motor capacity is for reference. Select it depending on the inverter model.

(3) For MCCB and ELCB, the upper position shows a product manufactured by Mitsubishi Electric Corporation, and the lower position by Fuji Electric Co., Ltd.

Use the specified MCCB and ELCB. Also, keep the power impedance of the inverter low. Keep a total of impedance including impedance of the power transformer, wiring impedance, and ACL inductance to 5 % or less. Install the fuse described in the above table into the inverter input part, regardless of whether power impedance is high or low. However, for large power capacity and in other cases, MCCB and ELCB described above may not have sufficient break capacity. Based on the technical manual provided from MCCB and ELCB manufacturers, select the model of MCCB and ELCB depending on required breaking capacity.

When the power supply does not have a leakage protection function, you should select rated current sensitivity based on the technical manual from manufacturers and then install ELCB.

- (4) For the fuse, the model CR2L(S)-\*\*/UL is a product manufactured by Fuji Electric Co., Ltd. (UL standard product), and 660GH-\*\* by HINODE ELECTRIC CO., LTD. (UL standard product). Install the fuse on L1/R, L2/S, and L3/T each.

Please attach the fuse described quantity in parallel to each phase.

- (5) For the main circuit contactor, the upper position shows a product manufactured by Mitsubishi Electric Corporation, and the lower position by Fuji Electric Co., Ltd. Use the main circuit contactor with rated current over values described above.
- (6) Plan the wiring between the inverter and the motor so that voltage drop is below 2 %. The table lists wire size for inside the board (3 m in length as MLFC) and for outside the board (30 m in length as CV (3 single conductor cable)).
- (7) Use the R type solderless terminal standardized by Japanese Industrial Standards (JIS C 2805) or the round-shape solderless terminal certified by UL/cUL.
- (8) For ELCB and the main circuit contactor for the applied motor capacity over 400 kW, contact us.
- (9) Use the ground wire with many element wires, such as UL wire, MLFC, and KIV. The brackets ([ ]) show the AWG number.
- (10) For size noted in the brackets of the wire size field, use it only when it corresponds to your wire size, provided that the inverter is updated without changing load.
- (11) Use the solderless terminal CB200-S12 of Japan Solderless Terminal Corporation.

### 3.5.4 Electrical Wire Size of Control Board and PG Input Board

The electrical wire size of the terminal block <TB1> on the control board <VFC66-Z> and the terminal block <TB2> on the PG input board <PG66-Z> is common to all inverter models.

Terminal block	Wiring size [mm <sup>2</sup> ]
Terminal block <TB1> on the control board <VFC66-Z> ([52MA] to [GND])	0.12 to 0.32 [AWG26 to 22]
Terminal block <TB2> on the PG input board <PG66-Z> ([+12] to [PGOUT])	0.12 to 0.32 [AWG26 to 22]

### 3.6 Inverter Selection and List of Applied Motors

The inverter can be used with the induction motor or the ED motor. Select the inverter so that its rated current is more than or equal to rated motor current. The table below lists examples of combinations with our standard motors.

Motor		Inverter	
Type	Rated voltage	200 V class	400 V class
Induction motor	180 V	○	×
	200 V	○	×
	360 V	×	○
	400 V	×	○
ED motor	190 V	○	×
	380 V	×	○

When using the inverter in the vector control with the speed sensor, set rated motor voltage to below 90 % of power supply voltage.

When rated motor voltage is equal to power supply voltage, control characteristics are deteriorated if speed exceeds 90 % of rated motor speed.

List of applied motor capacity (induction motor)

Inverter model	Rated motor voltage		Inverter model	Rated motor voltage	
	200 V	180 V		400 V	360 V
2R222	2.2 kW	1.5 kW	2R244	2.2 kW	2.2 kW*
3R722	3.7 kW	2.2 kW	3R744	3.7 kW	3.7 kW*
5R522	5.5 kW	3.7 kW	5R544	5.5 kW	3.7 kW
7R522	7.5 kW	5.5 kW	7R544	7.5 kW	5.5 kW
1122	11.0 kW	7.5 kW	1144	11.0 kW	7.5 kW
1522	15.0 kW	11.0 kW	1544	15.0 kW	11.0 kW
2222	22.0 kW	18.5 kW	2244	22.0 kW	18.5 kW
3022	30.0 kW	22.0 kW	3044	30.0 kW	22.0 kW
3722	37.0 kW	30.0 kW	3744	37.0 kW	30.0 kW
4522	45.0 kW	37.0 kW	4544	45.0 kW	37.0 kW
5522	55.0 kW	45.0 kW	5544	55.0 kW	45.0 kW
7522	75.0 kW	55.0 kW	7544	75.0 kW	55.0 kW
9022	90.0 kW	75.0 kW	11044	110 kW	90.0 kW
15022	150 kW	132 kW	16044	160 kW	132 kW
18022	180 kW	160 kW	20044	200 kW	160 kW, 180 kW

Inverter model	Rated motor voltage		Inverter model	Rated motor voltage	
	200 V	180 V		400 V	360 V
			25044	250 kW	200 kW, 220 kW
			31544	315 kW	280 kW
			40044	400 kW	355 kW
			50044	500 kW	450 kW
			60044	600 kW	530 kW
			75044	750 kW	670 kW
			100044	1000 kW	900 kW

(Note) The motor capacity marked with \* does not require capacity derating.

List of applied motor capacity (ED motor)

Inverter model	Rated motor voltage		Inverter model	Rated motor voltage	
	190 V			380 V	
2R222	2.2 kW		2R244	2.2 kW	
3R722	3.7 kW		3R744	3.7 kW	
5R522	5.5 kW		5R544	5.5 kW	
7R522	7.5 kW		7R544	7.5 kW	
1122	11.0 kW		1144	11.0 kW	
1522	15.0 kW		1544	15.0 kW	
2222	18.5 kW, 22.0 kW		2244	18.5 kW, 22.0 kW	
3022	30.0 kW		3044	30.0 kW	
3722	37.0 kW		3744	37.0 kW	
4522	45.0 kW		4544	45.0 kW	
5522	55.0 kW		5544	55.0 kW	
7522	65.0 kW, 75.0 kW		7544	65.0 kW, 75.0 kW	
9022	90.0 kW		11044	90.0 kW, 110 kW	
15022	—		16044	132 kW, 160 kW	
18022	—		20044	200 kW	
			25044	250 kW	
			31544	315 kW, 375 kW*	
			40044	375 kW, 400 kW*	
			50044	400 kW, 500 kW	
			60044	600 kW	
			75044	750 kW	
			100044	—	

(Note) When the inverter is used in the constant output (power constant) state, the motor capacity marked with \* requires a higher-grade inverter model.

## Chapter 4 Basic Operating Procedures for Inverter

### 4.1 Basic Operating Procedures from Console

#### 4.1.1 Explanation of Display and Operation Keys on Console

On the console of the inverter, you can operate it, read and write each function setting data, display operating states, and display what are protected during protection operations.

The console consists of the components listed below: displays (1) through (3) and operation keys (4).

- 1: Seven-segment display
- 2: Unit LED
- 3: Status display LED
- 4: Operation keys

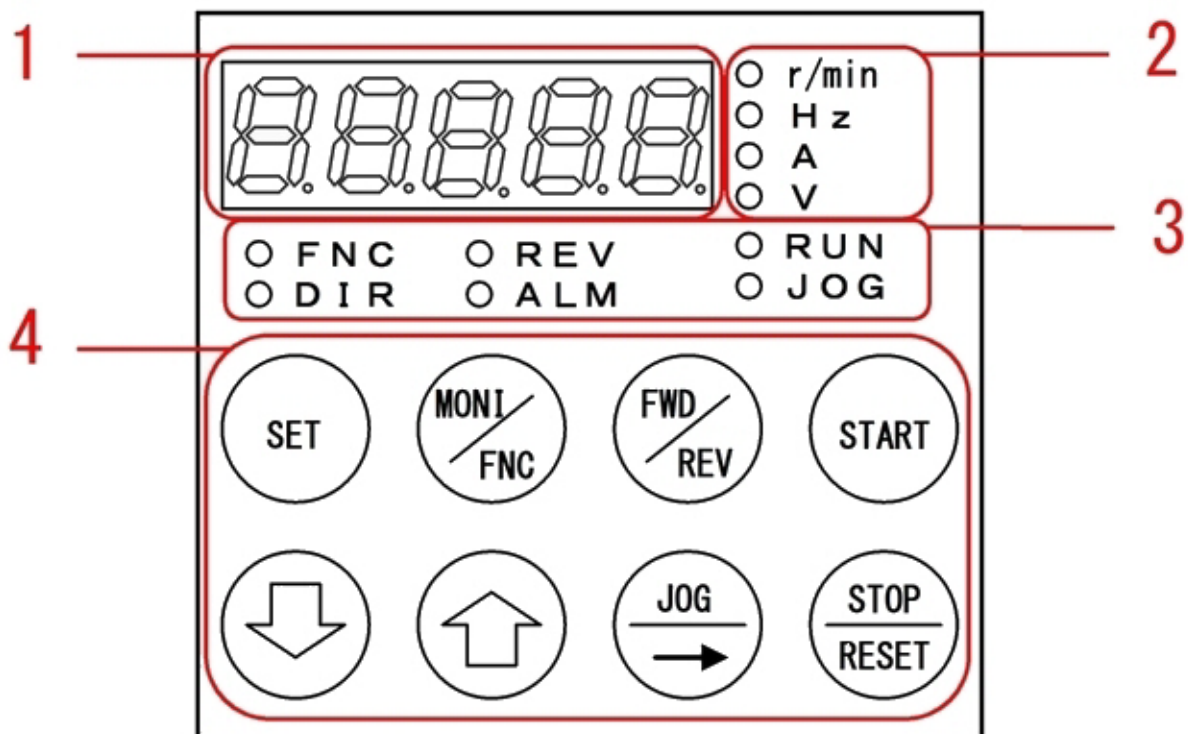

#### Inverter operation

In addition to using the console described below, you can operate the inverter and set various functions in the following ways:

- External console option <SET66EX-Z>
- Contact input and analog input
- Control through external digital communication
- Internal PLC function

Sometimes you cannot operate the inverter from the console, depending on settings.

■ Overview of the operation from the console

The console provides three types of operation modes.

- Monitor (MONI) mode
- Function setting (FNC) mode
- Protection display mode

The operation overview is described below.

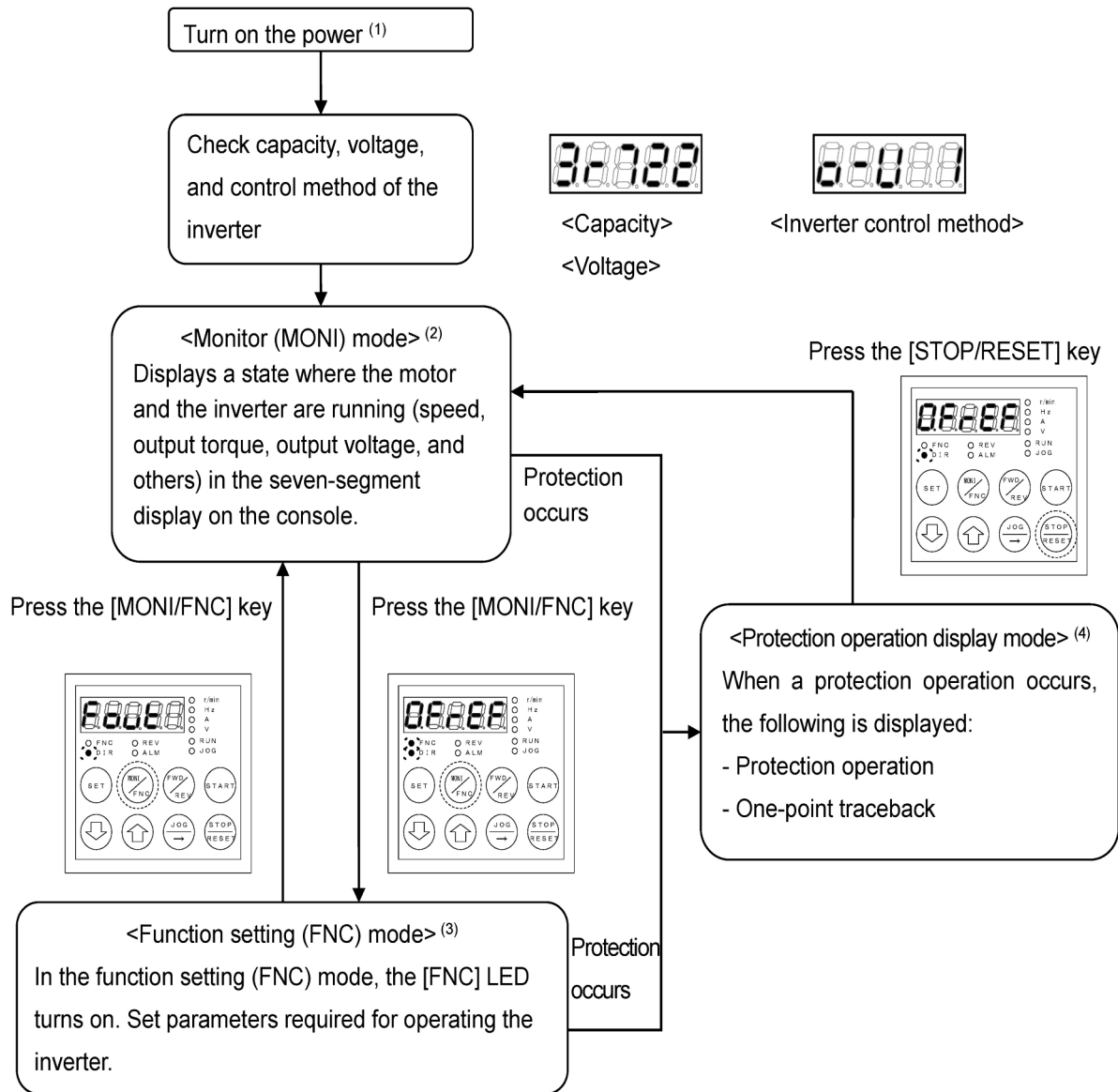

- (1) For what are displayed at power-on and their details, refer to {4.1.2 What Are Displayed at Power-on}.
- (2) In the monitor (MONI) mode, a monitor item is displayed, and about one second later its data is displayed. For details, refer to {4.1.6 Checking Operating State} and {4.1.7 List of Monitor Items}.
- (3) In the function setting (FNC) mode, parameter setting items and their values can be switched and displayed.
- (4) In the protection display mode, a protection operation item in the seven-segment display will blink to notify you. Output will stop. For details, refer to {6.1 Protection Displays and Actions}.

### ■ Descriptions of the display part

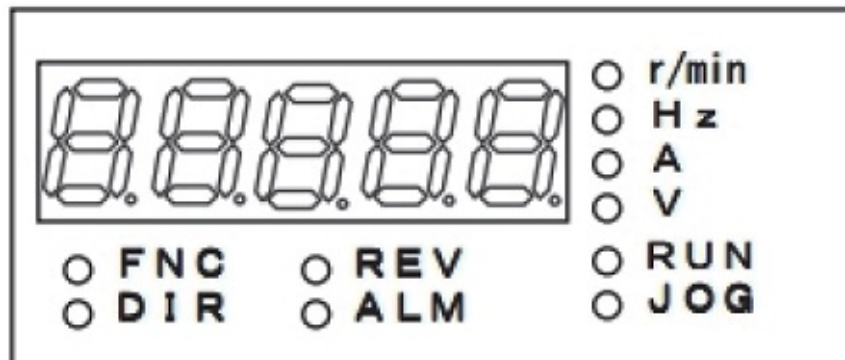

- **Seven-segment display**

It displays alphanumeric characters as seven-segment. For details, refer to the next section "Basic reading of the seven-segment display."

It displays operating states, functional symbols (numbers), function selection and setting data, protection operations, and protection histories.

When only one digit of alphanumeric characters blinks, it indicates that this becomes an operating digit. You can change alphanumeric characters of the operating digit by using keys [↑] and [↓].

- **Unit display LED**

The LED (r/min, Hz, A, or V) corresponding to the unit of numerical values in the seven-segment display turns on.

- **Status display LED**

FNC: It turns on when the function setting (FNC) mode is selected.

DIR: It turns on when the [START] key or the [JOG/→] key is enabled for operation from the console.

REV: It turns on when the rotation direction of the motor is set to reverse.

ALM: It turns on when cumulative operation time exceeds a specified time.

RUN: It turns on while the inverter is running. It blinks while the inverter is decelerating to stop or putting on the DC brake.

JOG: It turns on while the inverter is jogging. Even when the inverter is running, it turns on along with the [RUN] LED.

■ Basic reading of the seven-segment display

The table below lists a mapping of the seven-segment display to alphanumeric characters.

Since they are represented as seven-segment, in particular, you should carefully check alphabets. Some alphabets are not used to avoid a difficulty in reading them.

LED								
Alphanumeric character	0	1	2	3	4	5 (S)	6	7
LED								
Alphanumeric character	8	9	A	b	c	C	d	E
LED								
Alphanumeric character	F	G	H	h	i	J	L	n (m)
LED								
Alphanumeric character	o	P	q	r	S (5)	t	u	V
LED								
Alphanumeric character	w	y	.	-	- (minus)	-1	-2	-3

■ Descriptions of the operation keys

The function of each operation key depends on the operation mode setting on the console.

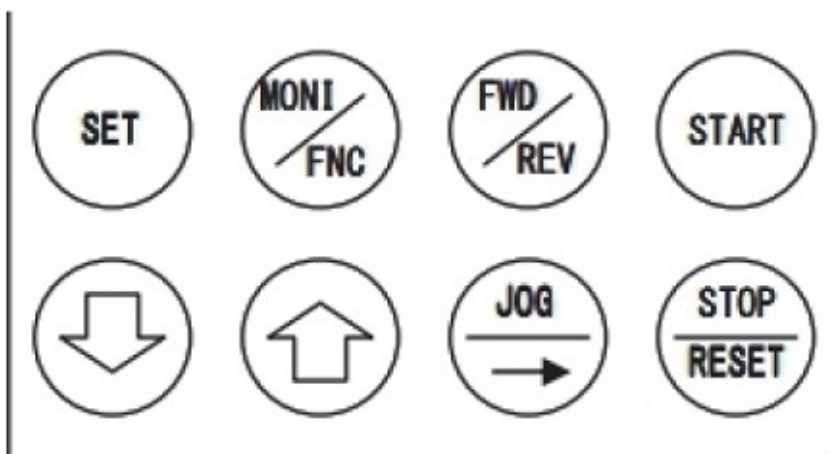

Operation keys in monitor (MONI) mode

[SET] key	Changes a monitor item (forward).
[MONI/FNC] key	Switches to the function setting (FNC) mode.

[FWD/REV] key	Switches between forward and reverse commands when the [START] key or the [JOG/→] key is enabled.
[START] key	Starts the inverter when "2" (Console) is set to the Operation_command_input_selection <b-11>.
[↓] key	Changes a monitor item (reverse).
[↑] key	Changes a monitor item (forward).
[JOG/→] key	Operates the inverter when "2" (Console) is set to the JOG_command_input_selection <b-12>.
[STOP/RESET] key	Stops the inverter when it was started with the [START] key.

## Operation keys in function setting (FNC) mode

[SET] key	Confirms your selection when you set a parameter setting item.
	Writes data of a parameter setting value.
[MONI/FNC] key	Switches to the monitor (MONI) mode.
[FWD/REV] key	No function
[START] key	No function
[↓] key	Changes a parameter setting item area in the alphabetical reverse order.
	Decreases a value of the operating digit by one when you specify a number or a value of a parameter setting item.
[↑] key	Changes a parameter setting item area in the alphabetical order.
	Increases a value of the operating digit by one when you specify a number or a value of a parameter setting item.
[JOG/→] key	Shifts the operating digit by one to the right.
[STOP/RESET] key	Stops the inverter when it was started with the [START] key.

## Operation keys in protection display mode

[SET] key	Reads out one-point traceback data.
[MONI/FNC] key	Moves to the monitor (MONI) mode or the function setting (FNC) mode.
[FWD/REV] key	No function
[START] key	
[↓] key	
[↑] key	
[JOG/→] key	
[STOP/RESET] key	Resets protection operation.

## ◆ Notes for each operation key

- **[MONI/FNC] key**  
It switches the monitor (MONI) mode to the function setting (FNC) mode and vice versa. The current mode is indicated by the [FNC] LED on or off.
- **[START] key, [JOG/→] key, [FWD/REV] key, [STOP/RESET] key**  
Only when these operation keys are enabled for operation from the console, you can operate the inverter by using them. When they are enabled, the [DIR] LED turns on.
- **[↑] key, [↓] key**  
Each time you press these keys, the display changes one by one. Also, when you press and hold them, the display changes continuously.

## ■ Basic operating procedures for keys

## (1) To move the operating digit

When you change various settings in the function setting (FNC) mode, a blinking digit of alphanumeric characters indicates that this becomes the operating digit.

You can shift the operating digit to the right by pressing the [JOG/→] key. However, a shift function to the left is not provided. If you press the [JOG/→] key while the operating digit is in the right edge of the seven-segment display, it moves to the leftmost digit or the maximum settable digit.

## (2) To change numerical values

How to set a negative value in the seven-segment display on the console

Use the [JOG/→] key to move the operating digit to the leftmost one and then use the key [↑] or [↓] to change a number.

- By pressing the [↑] key

A number changes in the following order: "0" -> "1" -> "2" -> ..... -> "8" -> "9" -> "-1" -> "-." After "9," a negative value is displayed.

- By pressing the [↓] key

A number changes in the following order: "0" -> "-." -> "-1" -> "9" -> ..... -> "3" -> "2" -> "1." After "0," a negative value is displayed.

### 4.1.2 What Are Displayed at Power-on

When the inverter is turned on, the following contents appear in the seven-segment display on the console:

**1. The inverter series name is displayed for 1.5 seconds.**



The inverter series name "VF66B" is displayed.

**2. The capacity and the voltage class of the inverter are displayed for 1.5 seconds.**

- Starting from the left, the first three digits show the inverter capacity, and the next two digits the voltage class.
- The inverter capacity is displayed in kW, and a decimal point is represented as "r."
- For a voltage class of 200 V, "22" is displayed, for 400 V, "44" is displayed.

In the left three digits, "3.7" is displayed. In the right two digits, "22" is displayed.



**3. Symbols for representing the setting block and the inverter control method are displayed for 1.5 seconds.**

- Starting from the leftmost digit, the items listed below are displayed:  
Control method of the first setting block - (hyphen)  
Control method of the second setting block  
Current setting block
- The inverter control method is represented as follows:  
[V/f control]: "o"  
[Induction motor vector control]: "V"  
[ED motor vector control]: "E"



The control method of the first setting block is "o," and that of the second setting block is "V." Currently, the first setting block is being selected.

For details of the inverter control method, refer to {4.1.5 Changing Inverter Control Methods}.

**4. The console enters the monitor (MONI) mode, and a monitor item is displayed for one second.**



"Fout" shows output frequency

**5. Data of the monitor item is displayed.**

- What is displayed depends on the setting of the inverter control method.
- For details of monitor items and their data, refer to {4.1.7 List of Monitor Items}.



Current output frequency is "0.0" Hz

### About setting blocks

The inverter has the first setting block and the second setting block, for each of which you can set different control methods and parameters (some parameters are common to both blocks).

You can operate one motor by switching the speed vector control without sensor drive and the vector control drive with speed sensor, or you can also switch the ED motor and the induction motor.

- Two motors cannot be operated at the same time.
- To use two motors, you need to use a contactor, etc. to switch between the wirings to the motors.

For which of the first or second setting block and which of the three control methods are currently used, you can check them based on what are displayed on the console at power-on.

- In the default setting, the first setting block is selected.  
To change the first setting block to the second setting block, use an external signal.
- For details, refer to {5.3.4 Area c}.

### About the cooling fan

When the inverter is turned on, the cooling fan installed on it also starts at the same time.

It behaves as follows:

- Power-on: It operates for five minutes after power-on and then stops. However, when the inverter is operated within five minutes after power-on, the cooling fan stops in one minute after the inverter stops.
- Running: It always operates.
- Stop: After the inverter stops, it operates for one minute and then stops.

### 4.1.3 Changing Parameter Settings

This section provides the basic operating procedures for checking and changing parameter settings required to operate the inverter on the console.

- Set the console to the function setting (FNC) mode.
- Two modes "simple mode" and "full mode" are provided for parameters, and the procedures are common to both of them. For differences between them, refer to {4.1.4 Changing Parameter Simple Mode and Full Mode}.
- Some parameters can be changed while the inverter is running. For details, refer to {5.1 List of Parameters That Can Be Changed in Simple Mode}.

#### Notation of inverter control methods

In subsequent sections, three types of inverter control methods are represented as follows:

- [V/f control] → [V/f]
- [Induction motor vector control] → [IM]
- [ED motor vector control] → [EDM]

For details of the control methods, refer to {4.1.5 Changing Inverter Control Methods}.

■ How to check parameter setting values

To check parameter settings of the inverter, perform the following steps on the console:

For example, this section provides procedures to display a setting value of the parameter <b-13> of the area b.

1. When the [FNC] LED on the console turns off, press the [MONI/FNC] key.



- The [FNC] LED turns on, and the console enters the function setting (FNC) mode.
- A setting item appears in the seven-segment display on the console. For example, immediately after the inverter is turned on, the first item of the basic setting area is displayed.



[V/f] Frequency\_command <0.FrEF>



[IM] [EDM] Speed\_command <0.SrEF>

2. Press the keys [↑] and [↓] to display the first setting item "b-00" of the area b.

- The alphabet character "b" in the setting item blinks, which indicates that this becomes the operating digit.



3. Press the [JOG/→] key once to blink "0" in the tens digit, and then press the keys [↑] and [↓] to change it to "1."



- As a result, "b-10" is displayed.



4. Press the [JOG/→] key once to blink "0" in the single digit, and then press the keys [↑] and [↓] to change it to "3."



- As a result, "b-13" is displayed.



5. Press the [SET] key.

- The selection of "b-13" is confirmed, and for example its Initialized data "150" is displayed as a current setting value.
- The display of the setting value automatically returns to that of the setting item in ten seconds.



6. Press the [MONI/FNC] key.

- The [FNC] LED turns off, and the console returns to the monitor (MONI) mode.
- The monitor item, which was displayed before setting the parameter, is displayed for about one second. Then, its data is displayed.

### Operating digit of parameter setting items

When setting items of the area A through area S are displayed, an alphabet character or a number blinks, which indicates that this becomes the operating digit.

Each time the [JOG/→] key is pressed, the operating digit moves in the following order: alphabet character → number in the tens digit → number in the single digit → alphabet character.

When a number in the single digit is changed, in some cases, a number in the tens digit is also changed. For example:

- Press the [↑] key: "b-09" → "b-10," "b-19" → "b-20," "b-99" → "b-00"
- Press the [↓] key: "b-10" → "b-09," "b-20" → "b-19," "b-00" → "b-99"

### ■ How to change parameter setting values

To manually set and change parameters of the inverter, perform the following steps on the console:  
For example, this section provides procedures for changing the parameter <b-13> of the area b from its initialized data "150" to "125."

#### 1. When the [FNC] LED on the console turns off, press the [MONI/FNC] key.

- The [FNC] LED turns on, and the console enters the function setting (FNC) mode.
- A setting item appears in the seven-segment display on the console. For example, immediately after the inverter is turned on, the first item of the basic setting area is displayed.

#### 2. Press the keys [↑] and [↓] to display the first setting item "b-00" of the area b.

- The alphabet character "b" in the setting item blinks, which indicates that this becomes the operating digit.



#### 3. Press the [JOG/→] key to blink numbers, and then press the keys [↑] and [↓] to change them to become "b-13."



#### 4. Press the [SET] key.

- The selection of "b-13" is confirmed, "150" is displayed as a current setting value.
- The operating digit blinks. In the initial setting, the maximum digit within the setting range (in this case "1") blinks.
- The display of the setting value automatically returns to that of the setting item in ten seconds.



#### 5. Press the [JOG/→] key once to blink "5," and then press the keys [↑] and [↓] to change it to "2."

- As a result, "120" is displayed.



#### 6. Press the [JOG/→] key once to blink "0," and then press the keys [↑] and [↓] to change it to "5."

- As a result, "125" is displayed.

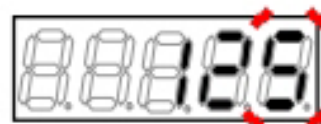

**7. Press the [SET] key.**

- The change is confirmed, and "b-13" is displayed again.
- The display of the setting value automatically returns to that of the setting item in ten seconds. Unless the [SET] key is pressed while a setting value is displayed, its change is not confirmed.
- To change other parameters, repeat the procedures from the step 2.

**8. Press the [MONI/FNC] key.**

- The [FNC] LED turns off, and the console returns to the monitor (MONI) mode.
- The monitor item, which was displayed before setting the parameter, is displayed for about one second. Then, its data is displayed.

### Operating digit of parameter setting values

The operating digit of a setting value is indicated by blinking.

- A number from "0" to "9," a minus sign "-", or an underscore "\_" (representing a blank) blinks.

Immediately after the setting value is displayed, the maximum digit within the setting range of that parameter blinks.

Therefore, immediately after the setting value is displayed, which becomes the operating digit depends on parameters.

For example:

- When selecting one of selecting items "0" to "3": A number in the single digit blinks.
- When "150" is set in the setting range of "0" to "150": "1" in the hundreds digit blinks.
- When "80" is set in the setting range of "0" to "150": An underscore blinks in the hundreds digit.

However, note that the display of the setting value of the parameter automatically returns to that of the setting item in ten seconds.

#### 4.1.4 Changing Parameter Simple Mode and Full Mode

The inverter provides two modes "simple mode" and "full mode" for parameters.

##### (1) Simple mode

In the "simple mode," only parameters required for basic operation can be displayed and changed.

- The inverter is set to the "simple mode" at the factory.
- For parameters that can be displayed and changed in the "simple mode," refer to {5.1 List of Parameters That Can Be Changed in Simple Mode}.

##### (2) Full Mode

In the "full mode," all parameters can be displayed and changed.

- For parameters which can be displayed and changed in the "full mode," refer to "Features of full mode" in this chapter, {5.2 List of Parameters in Full Mode}, and {5.3 Detailed Explanation of Parameters}.

##### ■ How to check current mode

To check which mode is currently applied to parameters, perform the following steps on the console:

##### 1. When the [FNC] LED on the console turns off, press the [MONI/FNC] key.

- The [FNC] LED turns on, and a setting item appears in the seven-segment display. For example, immediately after the inverter is turned on, the first item of the basic setting area is displayed.

2. Press the keys [↑] and [↓] continuously to check that other items in addition to the basic setting area items, "A-00," "b-00," and "S-00" are displayed.



- When only basic setting area items, "A-00," "b-00," and "S-00" are displayed, it indicates that the "simple mode" is applied.
- When "c-00," "P-00," and others are displayed, it indicates that the "full mode" is applied.

In the "full mode," "P-00" is displayed.



##### 3. Press the [MONI/FNC] key.

- The [FNC] LED turns off, after a monitor item is displayed for about one second, its data appears.

Also, you can check the mode with the Inverter\_operation\_mode\_monitor <L-21>. For details, refer to {5.3.12 Area L}.

### ■ Features of full mode

The inverter provides parameters of a total of 16 areas: "basic setting area" and "area A" through "area S" which are listed in the table below.

In the "full mode," parameters of all areas can be displayed and changed. On the other hand, in the "simple mode," only parameters of some areas can be displayed and changed.

For detailed explanation of each parameter, refer to {5.3 Detailed Explanation of Parameters}.

### Switching mode and setting values

When you switch the mode to the "simple mode" after changing a setting value in the "full mode," Initialized data will be used for the items having "○" in the "Use Initialized data in simple mode" field in the table below.

Also, when you switch the mode to the "simple mode" after setting the parameters of the "area c" through the "area P" in the "full mode" and then you change it to the "full mode" once again, the values previously specified in the "full mode" are used for those of the "area c" through the "area P."

#### List of inverter setting areas

Setting area	Main contents	Simple mode	Setting for each block	Use Initialized data in simple mode	Remarks
Basic	Frequency setting Jog frequency setting Acceleration or deceleration time (1) and (2)	○	Yes	—	
A	Maximum frequency Rated motor	○	Yes	—	
b	Rewrite protection Stop mode and stop frequency Instantaneous power interruption and reverse prohibition Operation/JOG/frequency command input selection Torque limit	○	Yes	—	
c	Multifunction input function selection	—	No	—	Also support standard terminals
d	Acceleration or deceleration time (3) and (4), and S-pattern acceleration or deceleration setting Preset frequency Jump frequency Functions related to MRH	—	Yes	○	
E	Boost mode Regeneration stall prevention Motor temperature compensation "ON" / "OFF" Current control gain Simulation mode Forward direction change	—	Yes	○	

Setting area	Main contents	Simple mode	Setting for each block	Use Initialized data in simple mode	Remarks
F	Overspeed protection, overload protection, and overtorque protection Traceback Cumulative operation timer Other protections	—	Yes	○	
G	Optional board analog input and output characteristics selection Temperature detection options Line speed monitor adjustment	—	No	○	
H	Multifunction output selection Multifunction output data	—	Yes	○	
i	Internal PLC Droop controls Second speed control gain and others Speed control selection, positioning, and others	—	Yes	○	
J	Communication options	—	No	○	
L	Vdc adjustment gain Analog input/output adjustment gain and offset Change simple/full mode	—	No	—	Specified through the area S
n	Control method and inverter capacity	—	Yes	—	Specified through the area S
o	Special adjustment	—	—	—	
P	For internal PLC	—	No	○	
S	Autotuning function and initialization Cumulative operation timer reset ROM rewrite protection	Partially available	No	—	<ul style="list-style-type: none"> <li>▪ Data is not memorized.</li> <li>▪ Only some data can be rewritten in the simple mode.</li> </ul>

### ■ How to change to the full mode

The inverter is set to the "simple mode" at the factory.

To change it to the "full mode," perform the following steps on the console:

The parameter to be changed is the Special\_mode\_selection <S-00>.

For details of how to change parameter settings, refer to {4.1.3 Changing Parameter Settings}.

#### 1. When the [FNC] LED on the console turns off, press the [MONI/FNC] key.

- The [FNC] LED turns on, and a setting item appears in the seven-segment display. For example, immediately after the inverter is turned on, the first item of the basic setting area is displayed.

#### 2. Press the keys [↑] and [↓] to display "S-00."

- When the first item of the basic setting area is displayed, press the [↓] key once to display "S-00."
- For details of the Special\_mode\_selection <S-00>, refer to {5.3.16 Area S}.



#### 3. Press the [SET] key.

- On the extreme right, "0" is displayed.
- The underscore blinks on the extreme left, which indicates that this becomes the operating digit.



#### 4. Press the [JOG/→] key to blink required digits, and then press the keys [↑] and [↓] to specify numbers to become "1040."

- "1040" is a password. It is required to change a setting of the Special\_mode\_selection <S-00>.



#### 5. Press the [SET] key.

- The password input is confirmed, and "S-00" is displayed again.
- When a different number from "1040" is input, "P-Err" indicating a password error is displayed. In this case, press the keys [↑] and [↓] to return to "S-00." Follow the procedures again from the step 3.



Display indicating a password error

**6. Press the [SET] key.**

- Again, "0" is displayed on the extreme right, and the underscore blinks on the extreme left.



**7. Press the [JOG/→] key four times to blink "0" in the single digit, and then press the keys [↑] and [↓] to change it to "4" (Switch the simple mode and full mode).**

- The display of the setting value automatically returns to that of the setting item in ten seconds. Unless a setting value is specified while it is displayed, it cannot be changed.

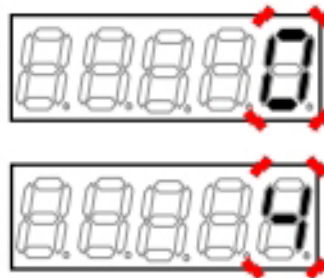

**8. Press the [SET] key.**

- The display of the setting value automatically returns to that of the setting item in ten seconds. Unless the [SET] key is pressed while a setting value is displayed, it is not confirmed.
- The selection is confirmed, and "FuLL" and "SurE" blink alternately. "FuLL" indicates the "full mode."

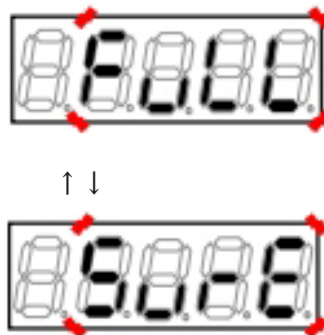

**9. Press the [SET] key.**

- The change is confirmed, and "S-00" is displayed again.
- This changes the mode to the "full mode." However, no change appears on the display of the console. For confirmation, refer to "■ How to check current mode" in this section {4.1.4}.



**10. Press the [MONI/FNC] key.**

- The [FNC] LED turns off, after a monitor item is displayed for about one second, its data appears.

**■ How to change to the simple mode**

To change the "full mode" to the "simple mode," follow the same steps as described in "■ How to change to the full mode."

In the step 8, "SnPL" and "SurE" blink alternately.

Here, press the [SET] key to change it to the "simple mode."

**Parameter setting values when changing to the simple mode**

When the mode is changed to the "simple mode," Initialized data shall be used in some parameters. For details, refer to "■ Features of full mode" in this section.

### 4.1.5 Changing Inverter Control Methods

Three types of control methods listed in the table below can be set in the inverter. In the initial state, the V/f control of the induction motor is set.

Symbol	Inverter control method	Descriptions
o	V/f control	Frequency of the induction motor can be controlled with keeping a ratio of voltage and frequency constant.
V	Induction motor vector control	Speed and torque of the induction motor can be controlled at high speed and high accuracy.
E	ED motor vector control	Speed and torque of the ED motor can be controlled at high speed and high accuracy.

#### ■ How to check current mode

To check which control method is currently set in the inverter, use the Inverter\_control\_mode <n-00>. Perform the following steps on the console:

These steps are enabled only when the parameter is in the "full mode." Before doing it, refer to {4.1.4 Changing Parameter Simple Mode and Full Mode} and change to the "full mode."

#### 1. When the [FNC] LED on the console turns off, press the [MONI/FNC] key.

- The [FNC] LED turns on, and a setting item appears in the seven-segment display. For example, immediately after the inverter is turned on, the first item of the basic setting area is displayed.

#### 2. Press the keys [↑] and [↓] to display "n-00."

- For details of the Inverter\_control\_mode <n-00>, refer to {5.3.13 Area n}.
- <n-00> is read-only. You cannot change the inverter control method with this parameter.



#### 3. Press the [SET] key.

- The selection of the parameter is confirmed, and either of "o," "V," or "E" is displayed as a current inverter control method.
- o: [V/f control]
- V: [Induction motor vector control]
- E: [ED motor vector control]



"o" indicates [V/f]

#### 4. Press the [MONI/FNC] key.

- The [FNC] LED turns off, after a monitor item is displayed for about one second, its data appears.

### ■ How to change the inverter control method

To change the inverter control method, perform the following steps on the console:

The parameter to be changed is the Special\_mode\_selection <S-00>.

For details of how to change parameter settings, refer to {4.1.3 Changing Parameter Settings}.

#### 1. When the [FNC] LED on the console turns off, press the [MONI/FNC] key.

- The [FNC] LED turns on, and a setting item appears in the seven-segment display. For example, immediately after the inverter is turned on, the first item of the basic setting area is displayed.

#### 2. Press the keys [↑] and [↓] to display "S-00."

- When the first item of the basic setting area is displayed, press the [↓] key once to display "S-00."
- For details of the Special\_mode\_selection <S-00>, refer to {5.3.16 Area S}.



#### 3. Press the [SET] key.

- On the extreme right, "0" is displayed.
- The underscore blinks on the extreme left, which indicates that this becomes the operating digit.



#### 4. Press the [JOG/→] key to blink required digits, and then press the keys [↑] and [↓] to specify numbers to become "1040."

- "1040" is a password. It is required to change a setting of the Special\_mode\_selection <S-00>.



#### 5. Press the [SET] key.

- The password input is confirmed, and "S-00" is displayed again.
- When a different number from "1040" is input, "P-Err" indicating an error is displayed. In this case, press the keys [↑] and [↓] to return to "S-00." Follow the procedures again from the step 3.
- Here, you can abort the procedures by pressing the [STOP/RESET] key.



Display indicating a password error

**6. Press the [SET] key.**

- Again, "0" is displayed on the extreme right, and the underscore blinks on the extreme left.



**7. Press the [JOG/→] key four times to blink "0" in the single digit, and then press the keys [↑] and [↓] to change it to "2" (Change the inverter control method).**

- The display of the setting value automatically returns to that of the setting item in ten seconds. Unless a setting value is specified while it is displayed, it cannot be changed.



**8. Press the [SET] key.**

- The display of the setting value automatically returns to that of the setting item in ten seconds. Unless the [SET] key is pressed while a setting value is displayed, it is not confirmed.
- A message of "CHAnGE inVErtEr Control" is displayed in turns.
- Then, "SurE" blinks.
- Here, you can abort the procedures by pressing the [STOP/RESET] key.



"SurE" blinks

**9. Press the [SET] key.**

- The selection is confirmed, and the control method of the first setting block is displayed. You will not find a blinking digit, but the rightmost digit becomes the operating digit.
- o: [V/f control]
- V: [Induction motor vector control]
- E: [ED motor vector control]



Display indicating the first setting block is "o"

**10. Use the keys [↑] and [↓] to change the inverter control method of the first setting block, and press the [SET] key.**



Display after changing to "V" of [IM]

- The control method of the second setting block is displayed.



11. Similarly, use the keys [↑] and [↓] to change the inverter control method of the second setting block, and press the [SET] key.

- After "CHAnG" is displayed for a few seconds, "End" is displayed. Now, the procedures to change the inverter control method are completed.
- About five seconds later, like what are displayed at power-on, the series name, capacity and voltage, and setting block and inverter control method of the inverter appear in the seven-segment display.
- Then, a monitor item is displayed for about one second, and its data is displayed.



### Setting blocks and inverter control methods

The inverter provides the first setting block and the second setting block, for each of which you can set different control methods.

In default, the first setting block is selected. For how to change the setting block, refer to {5.3.4 Area c}.

### 4.1.6 Checking Operating State

The inverter can display data such as motor speed, current, and voltage on the console while it is running. A total of 24 monitor items are provided. For contents of each item, refer to {4.1.7 List of Monitor Items}. To change a monitor item, perform the following steps on the console:

**1. When the [FNC] LED on the console turns on, press the [MONI/FNC] key.**

- The [FNC] LED turns off, and the console enters the monitor (MONI) mode.

**2. The monitor item currently set is displayed.**



"Fout" shows output frequency

- About one second later, data of the monitor item is automatically displayed.



"0.0" Hz is displayed as output frequency

**3. Press either of the [SET] key, [↑] key, or [↓] key to return to the display of the monitor item.**



Display example of output frequency <Fout> in [V/f]

**4. Press either of the [SET] key, [↑] key, or [↓] key while the monitor item is displayed.**

- The next monitor item is displayed.
- About one second later, data of the monitor item is automatically displayed.
- The display order of the monitor items will differ between the [SET]/[↑] key and the [↓] key.



Display after pressing the [↑] key in [V/f]

[SET] key, [↑] key	Top to bottom in the list of monitor items
[↓] key	Bottom to top in the list of monitor items

For the types and order of monitor items, refer to the next section {4.1.7 List of Monitor Items}.

### 4.1.7 List of Monitor Items

The table below lists all monitor items which appear in the seven-segment display on the console in the monitor (MONI) mode.

For details of how to change the display of monitor items, refer to {4.1.6 Checking Operating State}. Press the [SET] key or [↑] key to change a monitor item from top down in the table, and the [↓] key from bottom up.

List of monitor items

Monitor contents	Display of selecting items	Unit	Remarks
Output frequency/ Motor speed	Fout/ SPd	Hz r/min	Displays output frequency/motor speed.
Frequency com- mand value/ Speed command value	FrEF/ SrEF	Hz r/min	Displays a value of frequency command/motor speed command.
Output current	iout	A	Displays an effective value of output current.
Output torque/ Torque command	tout/ trEF	%	[V/f] Displays a calculated value of output torque. Accuracy is not guaranteed in the V/f control. [IM] [EDM] Displays a torque command after limit input into the torque control part is processed.
Direct-current voltage	Vdc	V	Displays direct-current voltage.
Output voltage	Vout	V	Displays an effective value of voltage between output lines.
Motor speed/ Output frequency	SPd/ Fout	r/min Hz	[V/f] Displays a value of motor speed converted from frequency. [IM] [EDM] Displays output frequency.
Overload protec- tion Counter	oLcnt	%	Displays a counter value of overload protection (oL) or overtorque protection (oT). When this value reaches 100 %, a protection operation starts.
Line speed	L_SP	m/min	Displays line speed as a ratio being a setting value of the Line_speed_monitor_adjustment at the maximum frequency/maximum speed. ▪ For a setting value of the line speed monitor, refer to {5.3.8 Area G}.
Motor temperature	tEnP	°C	Displays motor temperature. ▪ A special optional board is required to measure motor temperature.

Monitor contents	Display of selecting items	Unit	Remarks
Input terminal check 1	i1cH	—	<p>Displays the state "ON"/"OFF" of the input terminal on the control board .</p> <p>Starting from the right digit, states of the following input terminals are displayed:</p> <p>[ST-F]: Operation through the external switch</p> <p>[MI1] through [MI4]: The input terminal on the control board .</p> <ul style="list-style-type: none"> <li>• Refer to another table "Displays of input and output terminal check."</li> <li>• "1" indicates "ON," and "0" indicates "OFF."</li> <li>• For [ST-F], refer to {4.5 Start and Stop through External Contact in V/f Control}.</li> <li>• For the settings of [MI1] through [MI4], refer to {5.3.4 Area c}.</li> </ul>
Input terminal check 2	i2cH	—	<p>Displays the state "ON"/"OFF" of the input terminal on the control board and optional board .</p> <p>Starting from the right digit, states of the following input terminals are displayed:</p> <p>[MI5]: The input terminal on the control board .</p> <p>[MI6] through [MI9]: Input terminals on the optional board</p> <ul style="list-style-type: none"> <li>• Refer to another table "Displays of input and output terminal check."</li> <li>• "1" indicates "ON," and "0" indicates "OFF."</li> <li>• For the setting of [MI5], refer to {5.3.4 Area c}.</li> <li>• For the settings of [MI6] through [MI9], refer to the "Instruction Manual" of the optional board.</li> </ul>
Input terminal check 3	i3cH	—	<p>Displays the state "ON"/"OFF" of the input terminals [MI10] through [MI14] on the optional board.</p> <p>Starting from the right digit, states of the following input terminals are displayed:</p> <p>[MI10] through [MI14]: Input terminals on the optional board</p> <ul style="list-style-type: none"> <li>• Refer to another table "Displays of input and output terminal check."</li> <li>• "1" indicates "ON," and "0" indicates "OFF."</li> <li>• For the settings of [MI10] through [MI14] , refer to the "Instruction Manual" of the optional board.</li> </ul>
Input terminal check 4	i4cH	—	<p>Displays the state "ON"/"OFF" of the input terminals [MI15] through [MI17] on the optional board.</p> <p>Starting from the right digit, states of the following input terminals are displayed:</p> <p>[MI15] through [MI17]: Input terminals on the optional board</p> <ul style="list-style-type: none"> <li>• Refer to another table "Displays of input and output terminal check."</li> <li>• "1" indicates "ON," and "0" indicates "OFF."</li> <li>• For the settings of [MI15] through [MI17] , refer to the "Instruction Manual" of the optional board.</li> </ul>

Monitor contents	Display of selecting items	Unit	Remarks
Output terminal check 1	o1cH	—	Starting from the right digit, displays the relay state and terminal state on the control board. [52MA]: Inverter operation [86A]: Inverter protection [MO1] through [MO2]: The output terminals on the control board ▪ Refer to another table "Displays of input and output terminal check." ▪ "1" indicates "ON," and "0" indicates "OFF." For the settings of [MO1] and [MO2], refer to {5.3.9 Area H}.
Output terminal check 2	o2cH	—	Displays the state "ON"/"OFF" of the output terminals [MO3] through [MO6] on the optional board. Starting from the right digit, states of the following output terminals are displayed: [MO3] through [MO6]: Output terminals on the optional board ▪ Refer to another table "Displays of input and output terminal check." ▪ "1" indicates "ON," and "0" indicates "OFF." ▪ For the settings of [MO3] through [MO6], refer to the "Instruction Manual" of the optional board.
Cumulative operation time	tin	Hr	Displays cumulative operation time.
Timer remaining time 1	tin1	Hr	Displays remaining time of the main circuit capacitor timer. 2.2 to 1000 kW models: When cumulative operation time exceeds 43800 hours (it can be changed in the "full mode"), the [ALM] LED turns on. ▪ This numerical value is a guideline of remaining life of the main circuit capacitor, which does not provide any guarantee. ▪ To set the Cumulative_operation_timer(1), refer to {5.3.7 Area F}. To clear the Timer_remaining_time1, refer to {5.3.16 Area S}.
Timer remaining time 2	tin2	Hr	Displays remaining time of the cooling fan timer. 2.2 to 1000 kW models: When cumulative operation time exceeds 21900 hours (it can be changed in the "full mode"), the [ALM] LED turns on. ▪ This numerical value is a guideline of remaining life of the cooling fan, which does not provide any guarantee. ▪ To set the Cumulative_operation_timer(2), refer to {5.3.7 Area F}. To clear the Timer_remaining_time2, refer to {5.3.16 Area S}.
Main unit version	VEr	—	Displays the version of the main unit program. ▪ For example: VF66B-02-A1 → h02A1
PLC function version	VErSq	—	Displays the date when a sequence ladder was created. ▪ For example: 2001-09-28 → h1928 Month is converted and displayed as follows: 10 → A, 11 → B, and 12 → C.
Analog input voltage	Vin	V	Displays voltage input into the terminal [AIN1] on the control board. ▪ Voltage input into the terminals [AIN2] through [AIN5] on the optional board can be also displayed. For how to set it, refer to {5.3.8 Area G}.
Adjustment monitor	SPdSP	—	Special monitor for special adjustment

Monitor contents	Display of selecting items	Unit	Remarks
Protection history display	trbLE	—	Displays the history of the last six protection items and the data of protection operations. • For details, refer to {6.4 How to Check Protection History}.

## Displays of input and output terminal check

Display digit	Leftmost	←	Middle	→	Rightmost
Input terminal check 1	MI4	MI3	MI2	MI1	ST-F
Input terminal check 2	MI9	MI8	MI7	MI6	MI5
Input terminal check 3	MI14	MI13	MI12	MI11	MI10
Input terminal check 4	Unused	Unused	MI17	MI16	MI15
Output terminal check 1	Unused	MO2	MO1	86A	52MA
Output terminal check 2	Unused	MO6	MO5	MO4	MO3

## 4.2 Operation Flow of Inverter

This section provides operating procedures for the inverter from the console.

After installing and connecting the inverter, perform Autotuning to automatically set the parameters for the motor to be used.

For how to perform Autotuning, refer to {4.3 Autotuning of Parameters (Automatic Setting)}.

For detailed procedures such as changing a frequency command and acceleration or deceleration time, refer to {4.4 Operations on Console}.

When the inverter can be operated from the console, the [DIR] LED turns on.

- In the initial state, it can be operated from the console.
- When the [DIR] LED turns off, refer to {5.3.3 Area b}.

■ Operation flow of V/f control

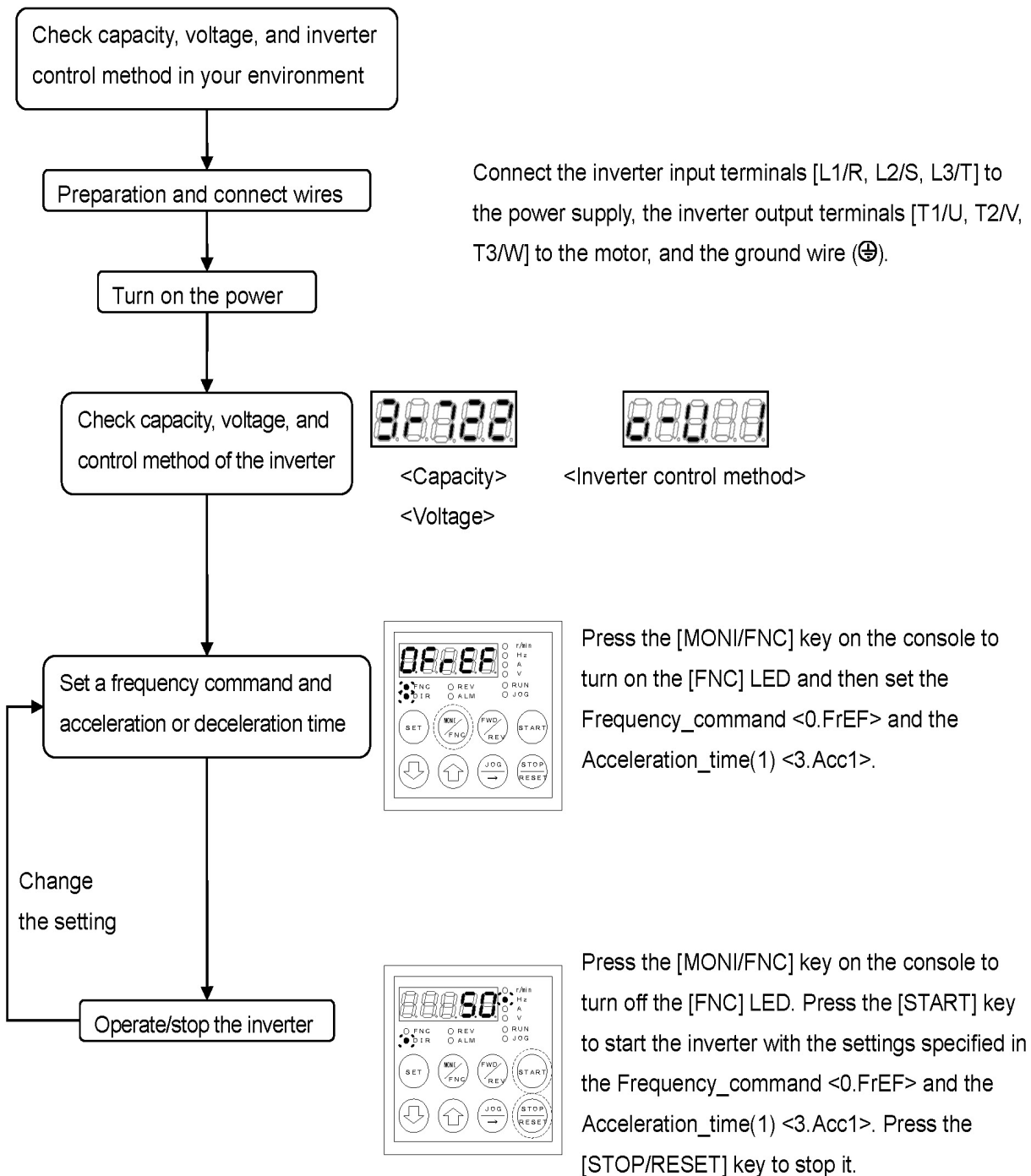

It is recommended that you perform Autotuning even when using the [V/f] control, like the [IM] control described in the next section.

■ Operation flow of induction motor vector control and ED motor vector control

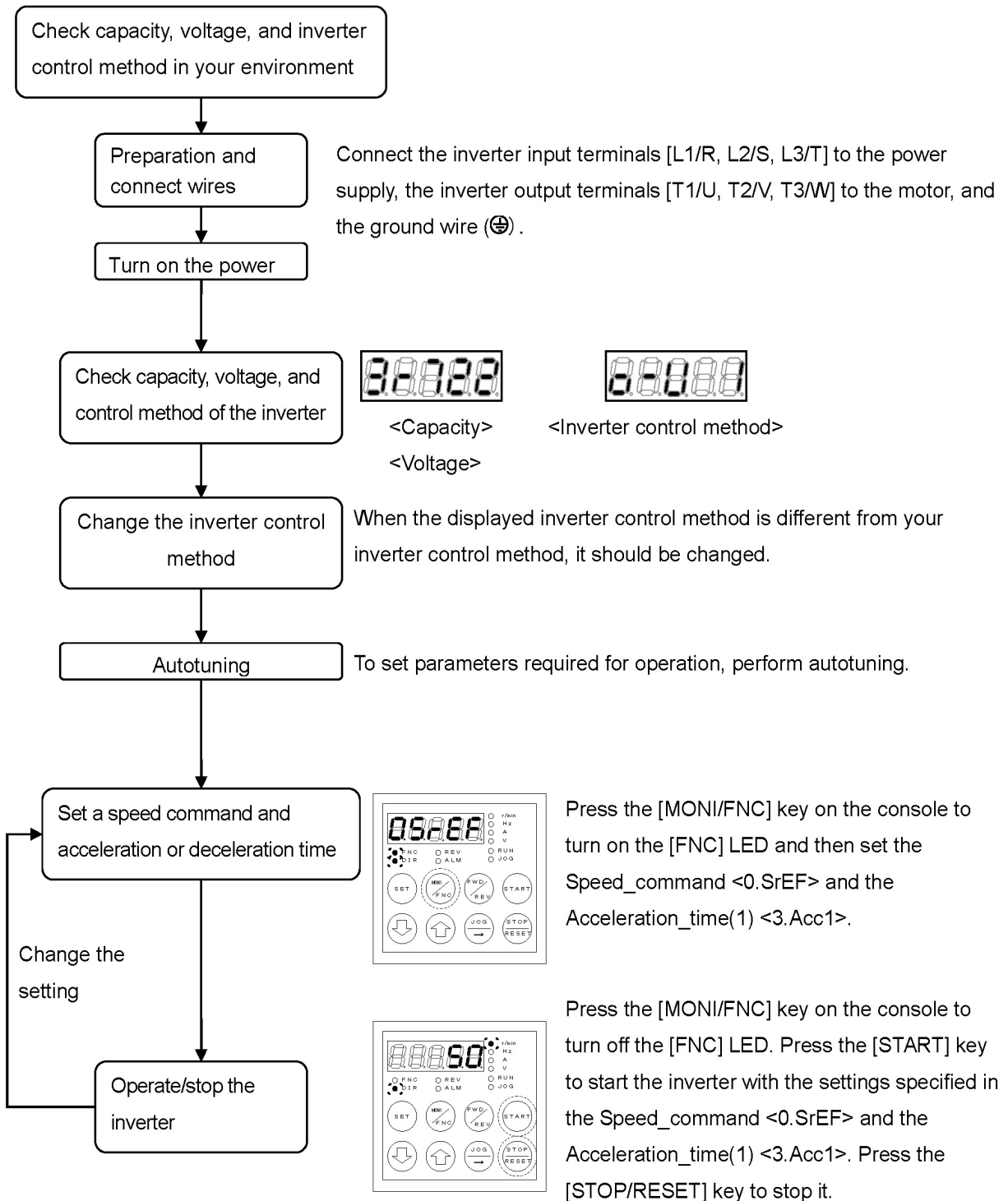

## 4.3 Autotuning of Parameters (Automatic Setting)

### 4.3.1 What Is Autotuning of Parameters?

Since the inverter executes control based on the motor parameters including motor resistance and inductance, you should first set such information to it.

The inverter provides an Autotuning function which enables the inverter itself to measure parameter information and automatically set parameter values.

#### ■ Need for Autotuning depending on the inverter control methods

In [V/f], when the parameters required for the motor are not set, you should conduct Autotuning to measure and set them.

In [IM] and [EDM], be sure to perform Autotuning before operation.

#### ■ Types of Autotuning

The following types of Autotuning are provided:

Types of Autotuning	[V/f]	[IM]	[EDM]	[Parameters automatically set]
Full Mode Autotuning (forward)	×	○	○	【IM】 <A-11>~<A-25> 【EDM】 <A-11>~<A-33>
Full Mode Autotuning (reverse)				
Direct Current Mode Autotuning (forward)	○	○	○	<A-11>~<A-17>
Direct Current Mode Autotuning (reverse)				
Motor D-axis Measurement Mode Autotuning (forward)	×	×	○	<A-30>
Motor D-axis Measurement Mode Autotuning (reverse)				

Full Mode Autotuning measures all required parameters.

Direct Current Mode Autotuning measures only primary resistance and deadtime compensation which are some of required parameters.

Motor D-axis Measurement Mode Autotuning measures the pole position of the ED motor.

### Motor temperature at Autotuning

Autotuning should be performed at 25°C or less for better performance of the inverter.

#### ■ Autotuning selection

In [IM] and [EDM], typically perform Full Mode Autotuning (forward).

For Direct Current Mode Autotuning (forward) and motor D-axis Measurement Mode Autotuning (forward), perform them as an additional adjustment of the motor whose Full Mode Autotuning has already been done. Also, only when each Autotuning (forward) cannot be performed in relation to load machines and others, you should perform each Autotuning (reverse).

### Autotuning in [V/f control]

In [V/f], standard motor parameters are preconfigured at the factory. Therefore, you can operate the inverter without conducting Autotuning of parameters.

However, for better performance of the inverter, it is recommended that you perform Direct Current Mode Autotuning after connecting the inverter to the motor.

### 4.3.2 Requirements for Performing Autotuning

Before Autotuning, on the console, you should set a rated value of the motor for which Autotuning will be performed.

Also, for [IM] and [EDM], separate the motor for Autotuning from load machines to ensure that it is isolated.

Set a rated value of the motor with the parameters <A-00> through <A-07>. For details of the setting range and others, refer to {5.3.2 Area A}.

Setting item	Contents	Applicable inverter control method
A-00	Maximum_frequency/Maximum_speed	Common to [V/f], [IM], and [EDM]
A-01	Minimum_frequency/Minimum_speed	
A-02	Rated_motor_capacity	
A-03	Rated_motor_voltage	
A-04	Rated_motor_current	
A-05	Rated_motor_speed	
A-06	Number_of_motor_pole	
A-07	Rated_motor_frequency	For [V/f] and [IM] only

In <A-02> through <A-07>, set each rated value described in the motor nameplate or the data sheet. For details of the settings, refer to {5.3.2 Area A}.

For the motor that has two types of rated voltage and rated current, set a larger value within the speed range in the Rated\_motor\_voltage <A-03> and the Rated\_motor\_current <A-04>.

When using the motor until the constant output (power constant) area in [IM] and [EDM], set the base speed in the Rated\_motor\_speed <A-05>.

Set a value described in the nameplate of your motor.

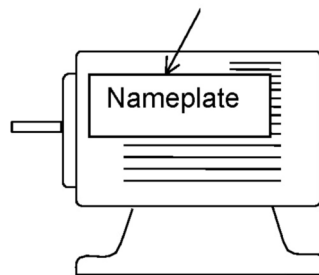

### ■ Setting rated motor values

To set a rated value of the motor, perform the following steps on the console:

For details of how to change parameter settings, refer to {4.1.3 Changing Parameter Settings}.

#### 1. When the [FNC] LED on the console turns off, press the [MONI/FNC] key.

- The [FNC] LED turns on, and a setting item appears in the seven-segment display. For example, immediately after the inverter is turned on, the first item of the basic setting area is displayed.

#### 2. Press the keys [↑] and [↓] to display "A-00."



#### 3. Press the [SET] key.

- The selection of "A-00" is confirmed, a current setting value is displayed.
- The display of the setting value automatically returns to that of the setting item in ten seconds. Unless a setting value is specified while it is displayed, it cannot be changed.



For [V/f], Initialized data "60.0" is displayed

#### 4. Press the [JOG/→] key to blink required digits, and then press the keys [↑] and [↓] to change numbers.

- To set a negative value, specify "-" in the leftmost digit.
- For data selection, use the keys [↑] and [↓] to select one.
- The display of the setting value automatically returns to that of the setting item in ten seconds. Unless a setting value is specified while it is displayed, it cannot be changed.



Display after changing to "200.0"

**5. After completing all the digits you need to change, press the [SET] key.**

- The display of the setting value automatically returns to that of the setting item in ten seconds. Unless the [SET] key is pressed while a setting value is displayed, the change cannot be confirmed.
- When data cannot be written, the contents below are displayed. Press the keys [↑] and [↓] to return to the display of the setting item.
- "u-Lim": Above the upper limit of setting range
- "L-Lim": Below the lower limit of setting range
- "PrtCt": Writing is prohibited by the Setting\_data\_rewrite\_protection <b-00>.
- "rtry": During memory operation or during power outage.



When a numerical value is too large



When a numerical value is too small



When rewriting is protected



During memory operation or during power outage

- The change is confirmed, and "A-00" is displayed again.



**6. Press the [JOG/→] key to blink the number, and then press the keys [↑] and [↓] to change it to become "A-01."**

- Repeat the steps 3 through 6 and set <A-01>.
- Similarly, set the parameters <A-02> through <A-07>.



**7. Press the [MONI/FNC] key.**

- The [FNC] LED turns off, after a monitor item is displayed for about one second, its data appears.



[V/f] Output frequency <Fout>



[IM] [EDM] Motor speed <SPd>

### 4.3.3 How to Perform Autotuning

#### ■ [IM] [EDM] Operating procedures for Full Mode Autotuning

For Full Mode Autotuning in [IM] and [EDM], perform the following steps on the console:

The parameter to be changed is the Special\_mode\_selection <S-00>.

For details of how to change parameter settings, refer to {4.1.3 Changing Parameter Settings}.

#### CAUTION [EDM] Full Mode Autotuning

- Do not perform Full Mode Autotuning when temperature of a motor shaft is higher than ambient temperature(40°C). In addition, do not repeatedly perform Full Mode Autotuning. Magnetic properties of ED motor may be reduced.

#### CAUTION [EDM] Full Mode Autotuning

- During Autotuning, voltage is applied to the ED motor even while the inverter is stopped. It may result in a risk of electric shock.

#### CAUTION [IM] [EDM] Full Mode Autotuning

- When Full Mode Autotuning is performed, the motor rotates. Separate it from load machines to ensure that it is isolated. Otherwise, machines may be damaged, or you may be injured.

#### 1. When the [FNC] LED on the console is off, press the [MONI/FNC] key.

- The [FNC] LED turns on, and a setting item appears in the seven-segment display. For example, immediately after the inverter is turned on, the first item of the basic setting area is displayed.

#### 2. Press the keys [↑] and [↓] to display "S-00."

- When the first item of the basic setting area is displayed, press the [↓] key once to display "S-00."
- For details of the Special\_mode\_selection <S-00>, refer to {5.3.16 Area S}.



#### 3. Press the [SET] key.

- On the extreme right, "0" is displayed.
- The underscore blinks on the extreme left, which indicates that this becomes the operating digit.



**4. Press the [JOG/→] key to blink required digits, and then press the keys [↑] and [↓] to specify numbers to become "1040."**

- "1040" is a password. It is required to change a setting of the Special\_mode\_selection <S-00>.



**5. Press the [SET] key.**

- The password input is confirmed, and "S-00" is displayed again.
- When a different number from "1040" is input, "P-Err" indicating an error is displayed. In this case, press the keys [↑] and [↓] to return to "S-00." Follow the procedures again from the step 3.



Display indicating a password error

**6. Press the [SET] key.**

- Again, "0" is displayed on the extreme right, and the underscore blinks on the extreme left.



**7. Press the [JOG/→] key to blink required digits, and then press the keys [↑] and [↓] to specify numbers to become "10" (forward) or "11" (reverse).**

- The display of the setting value automatically returns to that of the setting item in ten seconds. Unless a setting value is specified while it is displayed, it cannot be changed.

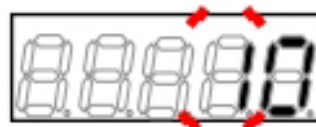

**8. Press the [SET] key.**

- Two digits on the right side show the setting block ("1" or "2") and Autotuning mode.
- The Autotuning mode is displayed as follows:  
 " " (blank): Full Mode  
 "d": Direct Current Mode  
 "P": Motor D-axis Measurement Mode



This shows the setting block "1" and the mode " " (full mode)

**9. Press the [JOG/→] key.**

- Autotuning starts, and "tunSt" is displayed.
- The motor behaves during Full Mode Autotuning as follows:



Autotuning starts

- (1) [IM] The four-pole motor makes about 1/2 revolution slowly, and then it accelerates until it reaches a speed of about 80 % of rated speed.
- (2) [EDM] After the six-pole motor makes about one revolution slowly, it performs measurement while it stops and then accelerates until it reaches a speed of about 80 % of rated speed.

**10. Autotuning automatically terminates.**

- When it normally terminates, "tunEd" is displayed.
- In case of abnormality, a protection message or "Err--" is displayed. For details and how to clear it, refer to {6.1.5 Meaning of Error Displays during Autotuning}.



Autotuning terminates



Error indication

**11. Press the [STOP/RESET] key for three seconds.**

- The inverter series name is displayed.
- Subsequently, the screen displays contents similar to what are displayed at power-on, and then the console returns to the monitor (MONI) mode. For details, refer to {4.1.2 What Are Displayed at Power-on}.



### ■ Operating procedures for Direct Current Mode Autotuning

For Direct Current Mode Autotuning, perform the following steps on the console:

The parameter to be changed is the Special\_mode\_selection <S-00>.

For details of how to change parameter settings, refer to {4.1.3 Changing Parameter Settings}.

## CAUTION [EDM] Direct Current Mode Autotuning

When Direct Current Mode Autotuning is performed in [EDM], the motor rotates. Therefore, isolate it from machines or release machine brakes to ensure that it can rotate freely.

Otherwise, machines may be damaged.

### 1. When the [FNC] LED on the console turns off, press the [MONI/FNC] key.

- The [FNC] LED turns on, and a setting item appears in the seven-segment display. For example, immediately after the inverter is turned on, the first item of the basic setting area is displayed.

### 2. Press the keys [↑] and [↓] to display "S-00."

- When the first item of the basic setting area is displayed, press the [↓] key once to display "S-00."
- For details of the Special\_mode\_selection <S-00>, refer to {5.3.16 Area S}.



### 3. Press the [SET] key.

- On the extreme right, "0" is displayed.
- The underscore blinks on the extreme left, which indicates that this becomes the operating digit.

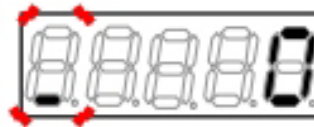

### 4. Press the [JOG/→] key to blink required digits, and then press the keys [↑] and [↓] to specify numbers to become "1040."

- "1040" is a password. It is required to change a setting of the Special\_mode\_selection <S-00>.



**5. Press the [SET] key.**

- The password input is confirmed, and "S-00" is displayed again.
- When a different number from "1040" is input, "P-Err" indicating an error is displayed. In this case, press the keys [↑] and [↓] to return to "S-00." Follow the procedures again from the step 3.



Display indicating a password error

**6. Press the [SET] key.**

- Again, "0" is displayed on the extreme right, and the underscore blinks on the extreme left.

**7. Press the [JOG/→] key to blink required digits, and then press the keys [↑] and [↓] to specify numbers to become "12" (forward) or "13" (reverse).**

- The display of the setting value automatically returns to that of the setting item in ten seconds. Unless a setting value is specified while it is displayed, it cannot be changed.

**8. Press the [SET] key.**

- Two digits on the right side show the setting block ("1" or "2") and Autotuning mode.
- The Autotuning mode is displayed as follows:
  - " " (blank): Full Mode
  - "d": Direct Current Mode
  - "P": Motor D-axis Measurement Mode



"1" and "d" indicate the setting block and mode (Direct Current), respectively

**9. Press the [JOG/→] key.**

- Autotuning starts, and "tunSt" is displayed.
- The motor behaves during Direct Current Mode Autotuning as follows:



Autotuning starts

- (1) [V/f] [IM] The four-pole motor makes about 1/2 revolution slowly, and then it may slowly make about 1/2 revolution in the forward and reverse directions each. Since the induction motor develops lower torque, it does not rotate if load is put on it or the machine brake is applied. Even when it does not rotate, Autotuning can be performed.
- (2) [EDM] The six-pole motor makes up to about 2/3 revolution slowly in the forward direction.

**10. Autotuning automatically terminates.**

- When it normally terminates, "tunEd" is displayed.
- In case of abnormality, a protection message or "Err--" is displayed. For details and how to clear it, refer to {6.1.5 Meaning of Error Displays during Autotuning}.



Autotuning terminates



Error indication

**11. Press the [STOP/RESET] key for three seconds.**

- The inverter model is displayed.
- Subsequently, the screen displays contents similar to what are displayed at power-on, and then the console returns to the monitor (MONI) mode. For details, refer to {4.1.2 What Are Displayed at Power-on}.



### ■ [EDM] Operating procedures for motor D-axis Measurement Mode Autotuning

For motor D-axis Measurement Mode Autotuning, perform the following steps on the console:

The parameter to be changed is the Special\_mode\_selection <S-00>.

For details of how to change parameter settings, refer to {4.1.3 Changing Parameter Settings}.

#### 1. When the [FNC] LED on the console turns off, press the [MONI/FNC] key.

- The [FNC] LED turns on, and a setting item appears in the seven-segment display. For example, immediately after the inverter is turned on, the first item of the basic setting area is displayed.

#### 2. Press the keys [↑] and [↓] to display "S-00."

- When the first item of the basic setting area is displayed, press the [↓] key once to display "S-00."
- For details of the Special\_mode\_selection <S-00>, refer to {5.3.16 Area S}.



#### 3. Press the [SET] key.

- On the extreme right, "0" is displayed.
- The underscore blinks on the extreme left, which indicates that this becomes the operating digit.



#### 4. Press the [JOG/→] key to blink required digits, and then press the keys [↑] and [↓] to specify numbers to become "1040."

- "1040" is a password. It is required to change a setting of the Special\_mode\_selection <S-00>.



#### 5. Press the [SET] key.

- The password input is confirmed, and the screen returns to "S-00" display.
- When a different number from "1040" is input, "P-Err" indicating an error is displayed. In this case, press the keys [↑] and [↓] to return to "S-00." Follow the procedures again from the step 3.



Display indicating a password error

**6. Press the [SET] key.**

- Again, "0" is displayed on the extreme right, and the underscore blinks on the extreme left.



**7. Press the [JOG/→] key to blink required digits, and then press the keys [↑] and [↓] to specify numbers to become "14" (forward) or "15" (reverse).**

- The display of the setting value automatically returns to that of the setting item in ten seconds. Unless a setting value is specified while it is displayed, it cannot be changed.

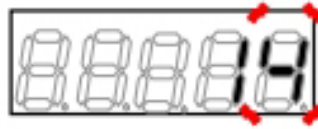

**8. Press the [SET] key.**

- Two digits on the right side show the setting block ("1" or "2") and Autotuning mode.
- The Autotuning mode is displayed as follows:  
 " " (blank): Full Mode  
 "d": Direct Current Mode  
 "P": Motor D-axis Measurement Mode



"1" and "P" indicate the setting block and mode (Motor D-axis Measurement), respectively

**9. Press the [JOG/→] key.**

- Autotuning starts, and "tunSt" is displayed.



Autotuning starts

**10. Autotuning automatically terminates.**

- When it normally terminates, "tunEd" is displayed.
- In case of abnormality, a protection message or "Err--" is displayed. For details and how to clear it, refer to {6.1.5 Meaning of Error Displays during Autotuning}.



Autotuning terminates



Error indication

**11. Press the [STOP/RESET] key for three seconds.**

- The inverter series name is displayed.
- Subsequently, the screen displays contents similar to what are displayed at power-on, and then the console returns to the monitor (MONI) mode. For details, refer to {4.1.2 What Are Displayed at Power-on}.



## 4.4 Operations on Console

### 4.4.1 Rotating Motor with Specified Frequency/Speed

To rotate the motor with a specified frequency/speed, perform the following steps on the console:

The parameter to be changed is the Frequency\_command <0.FrEF>/Speed\_command <0.SrEF>. For details of how to change parameter settings, refer to {4.1.3 Changing Parameter Settings}.

#### 1. When the [FNC] LED on the console turns off, press the [MONI/FNC] key.

- The [FNC] LED turns on, and a setting item appears in the seven-segment display. For example, immediately after the inverter is turned on, the first item of the basic setting area is displayed.

#### 2. Press the keys [↑] and [↓] to display the Frequency\_command <0.FrEF>/Speed\_command <0.SrEF>.

- For details of the Frequency\_command <0.FrEF>/Speed\_command <0.SrEF>, refer to {5.3.1 Basic Setting Area}.

#### 3. Press the [SET] key.

- The selection of the setting item is confirmed, a current setting value is displayed.
- The display of the setting value automatically returns to that of the setting item in ten seconds. Unless a setting value is specified while it is displayed, it cannot be changed.



"0.5" indicates Initialized data (Hz) of the Frequency\_command in [V/f]

#### 4. Press the [JOG/→] key to blink required digits, and then press the keys [↑] and [↓] to change numbers (frequency/speed).

- The setting range depends on the inverter control method.
- [V/f] The setting range in the default setting is -60.0 to 60.0 Hz.
- [IM] [EDM] The setting range in the default setting is -1800 to 1800 r/min.



Frequency\_command changed to "10.0" Hz in [V/f]

#### 5. Press the [SET] key.

- The change is confirmed, and the Frequency\_command <0.FrEF>/Speed\_command <0.SrEF> is displayed again.
- The display of the setting value automatically returns to that of the setting item in ten seconds. Unless the [SET] key is pressed while a setting value is displayed, the change cannot be confirmed.

#### 6. Press the [MONI/FNC] key.

- The [FNC] LED turns off, after a monitor item is displayed for about one second, its data appears.

**7. Press the [START] key.**

- The inverter starts, the motor starts to rotate, and then their frequency/speed changes until it reaches the setting value.
- While it operates, the currently set monitor item data is displayed.
- If the motor does not rotate even when the [START] key is pressed, change the settings of the Frequency\_command <0.FrEF>/Speed\_command <0.SrEF>. You can change them even while the inverter is running.



"10.0" Hz displayed as current output frequency in [V/f]

**8. Press the [STOP/RESET] key.**

- The inverter stops, and rotation of the motor stops.



"0.0" Hz displayed as output frequency when the inverter is stopped in [V/f]

[V/f] Setting range, Initialized data, and unit of Frequency\_command

Display	Contents	Setting range	Initialized data	Unit	Driving ReWrite
0.FrEF	Frequency_command	-Maximum_frequency <A-00> to +Maximum_frequency <A-00>	0.5	Hz	○

[IM] [EDM] Setting range, Initialized data, and unit of Speed\_command

Display	Contents	Setting range	Initialized data	Unit	Driving ReWrite
0.SrEF	Speed_command	-Maximum_speed <A-00> to +Maximum_speed <A-00>	0	r/min	○

For details of the Maximum\_frequency/Maximum\_speed <A-00>, refer to {5.3.2 Area A}.

## 4.4.2 Changing Acceleration or Deceleration Time

To change acceleration or deceleration time, perform the following steps on the console:

The parameters to be changed are the Acceleration\_time(1) <3.Acc1> and Deceleration\_time(1) <4.dEc1>. For details of how to change parameter settings, refer to {4.1.3 Changing Parameter Settings}.

### 1. When the [FNC] LED on the console turns off, press the [MONI/FNC] key.

- The [FNC] LED turns on, and a setting item appears in the seven-segment display. For example, immediately after the inverter is turned on, the first item of the basic setting area is displayed.

### 2. Press the keys [↑] and [↓] to display the Acceleration\_time(1) <3.Acc1> or Deceleration\_time(1) <4.dEc1>.

- To change acceleration time, select "3.Acc1." To change deceleration time, select "4.dEc1."
- This parameter is common to [V/f], [IM], and [EDM].
- For details of the Acceleration\_time(1) <3.Acc1> and Deceleration\_time(1) <4.dEc1>, refer to {5.3.1 Basic Setting Area}.



To change acceleration time



To change deceleration time

### 3. Press the [SET] key.

- The selection of the setting item is confirmed, a current setting value is displayed.
- The display of the setting value automatically returns to that of the setting item in ten seconds. Unless a setting value is specified while it is displayed, it cannot be changed.



"30.0" indicates Initialized data (sec) of the Acceleration\_time(1)

### 4. Press the [JOG/→] key to blink a required digit, and then press the keys [↑] and [↓] to change the number (acceleration or deceleration time).

- The setting range is 0.0 to 3600.0 sec.



Acceleration time changed to "50.0" sec

**5. Press the [SET] key.**

- The display of the setting value automatically returns to that of the setting item in ten seconds. Unless the [SET] key is pressed while a setting value is displayed, the change cannot be confirmed.
- The change is confirmed, and the Acceleration\_time(1) <3.Acc1> or Deceleration\_time(1) <4.dEc1> is displayed again.



Display after changing the acceleration time



Display after changing the deceleration time

**6. Press the [MONI/FNC] key.**

- The [FNC] LED turns off, after a monitor item is displayed for about one second, its data appears.

**7. Press the [START] key.**

- The inverter starts, the motor starts to rotate, and then it accelerates or decelerates until it reaches the specified acceleration or deceleration time.
- While the inverter is in operation, the currently set monitor item data is displayed.
- You can change acceleration or deceleration time while the inverter is running.



"10.0" Hz displayed as current output frequency in [V/f]

**8. Press the [STOP/RESET] key.**

- The inverter stops, and rotation of the motor stops.



"0.0" Hz displayed as output frequency when the inverter is stopped in [V/f]

Setting range, Initialized data, and unit of Acceleration\_time(1) and Deceleration\_time(1)

Display	Contents	Setting range	Initialized data	Unit	Driving ReWrite
3.Acc1	Acceleration_time(1)	0.0 to 3600.0	30.0	sec	○
4.dEc1	Deceleration_time(1)				

■ What is acceleration or deceleration time?

The motor behaves as shown in the figure below.

When acceleration time is increased, a slope of Time - Frequency/speed is decreased. In this case, it takes long time for the motor to reach the setting value of the Maximum\_frequency/Maximum\_speed.

Conversely, when acceleration time is decreased, a slope of Time - Frequency/speed is increased. It takes short time for the motor to reach the setting value of the Maximum\_frequency/Maximum\_speed.

If current is too much when it accelerates or an overvoltage protection (oV) occurs when it decelerates, you should increase setting values of the Acceleration\_time(1) and Deceleration\_time(1).

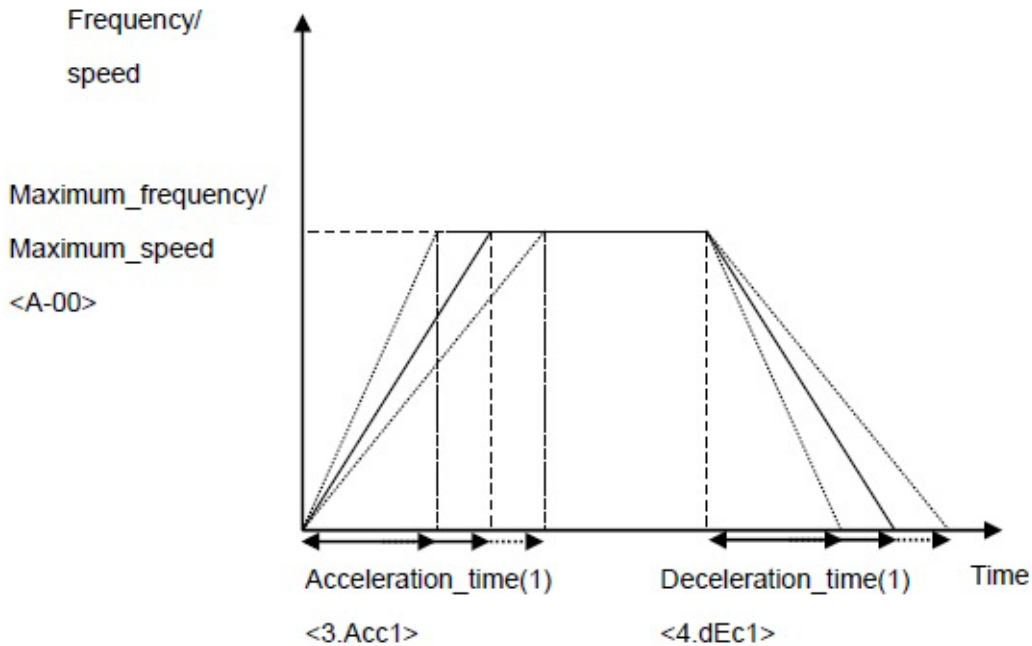

For details of the Maximum\_frequency/Maximum\_speed <A-00>, refer to {5.3.2 Area A}.

### 4.4.3 Changing Rotation Direction

To change rotation direction, perform the following steps on the console:

You can do it while the inverter is either in operation or stopped.

**1. When the [FNC] LED on the console turns on, press the [MONI/FNC] key.**

- The [FNC] LED turns off, and the console enters the monitor (MONI) mode.
- A monitor item is displayed for about one second, and its data is displayed.

**2. Press the [FWD/REV] key.**

- Rotation direction of the motor changes.
- When the [REV] LED turned off, it turns on. This indicates that rotation direction of the motor is reverse. Conversely, when the [REV] LED turned on, it turns off. This indicates that rotation direction of the motor is forward.
- The frequency/speed remains unchanged before the direction is changed.

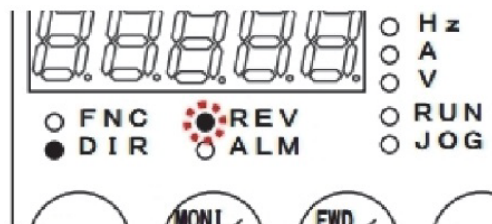

#### ■ Setting a negative value to a command

You can reverse rotation of the motor by setting a negative value to the Frequency\_command <0.FrEF>/Speed\_command <0.SrEF> in the section {4.4.1 Rotating Motor with Specified Frequency/Speed}.

For how to set a negative value, refer to {4.1.1 Explanation of Display and Operation Keys on Console}. You can change the setting of the Frequency\_command <0.FrEF>/Speed\_command <0.SrEF> while the inverter is in operation.

### 4.4.4 How to Perform JOG Operation

For JOG operation, use the [JOG/→] key on the console to perform the following steps:

#### 1. When the [FNC] LED on the console turns on, press the [MONI/FNC] key.

- The [FNC] LED turns off, and the console enters the monitor (MONI) mode.
- A monitor item is displayed for about one second, and its data is displayed.

#### 2. Press the [JOG/→] key.

- Only while the [JOG/→] key is pressed, the motor performs JOG operation.
- The [RUN] LED and [JOG] LED turn on.

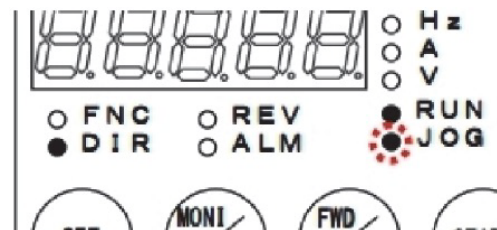

#### 3. Release the [JOG/→] key.

- JOG operation stops.
- The [RUN] LED and [JOG] LED turn off.

### 4.4.5 Changing JOG Frequency/Speed

To change JOG frequency/speed, perform the following steps on the console:

The parameters to be changed are the Forward\_JOG\_frequency/Forward\_JOG\_speed <1.FJoG> and the Reverse\_JOG\_frequency/Reverse\_JOG\_speed <2.rJoG>.

For details of how to change parameter settings, refer to {4.1.3 Changing Parameter Settings}.

#### 1. When the [FNC] LED on the console turns off, press the [MONI/FNC] key.

- The [FNC] LED turns on, and a setting item appears in the seven-segment display. For example, immediately after the inverter is turned on, the first item of the basic setting area is displayed.

#### 2. Press the keys [↑] and [↓] to display "1.FJoG" (Forward\_JOG\_frequency/Forward\_JOG\_speed) or "2.rJoG" (Reverse\_JOG\_frequency/Reverse\_JOG\_speed).

- For JOG operation, you can set different values for forward and reverse.
- To change frequency/speed of forward JOG operation, select "1.FJoG."
- To change frequency/speed of reverse JOG operation, select "2.rJoG."
- For details of the Forward\_JOG\_frequency/Forward\_JOG\_speed <1.FJoG> and the Reverse\_JOG\_frequency/Reverse\_JOG\_speed <2.rJoG>, refer to {5.3.1 Basic Setting Area}.



For forward JOG



For reverse JOG

#### 3. Press the [SET] key.

- The selection of the setting item is confirmed, a current setting value is displayed.
- The display of the setting value automatically returns to that of the setting item in ten seconds. Unless a setting value is specified while it is displayed, it cannot be changed.



"1.0" indicates Initialized data (Hz) of the Forward\_JOG\_frequency in [V/f]

#### 4. Press the [JOG/→] key to blink a required digit, and then press the keys [↑] and [↓] to change the number (forward and reverse JOG frequency/speed).

- The setting range depends on the inverter mode.
- [V/f] The setting range in the default setting is 0.5 to 30.0 Hz for forward and -30.0 to -0.5 Hz for reverse.
- [IM] [EDM] The setting range in the default setting is 12 to 300 r/min for forward and -300 to -12 r/min for reverse.



Forward\_JOG\_frequency changed to "2.0" Hz in [V/f]

**5. Press the [SET] key.**

- The display of the setting value automatically returns to that of the setting item in ten seconds. Unless the [SET] key is pressed while a setting value is displayed, the change cannot be confirmed.
- The change is confirmed, and the Forward\_JOG\_frequency/Forward\_JOG\_speed <1.FJoG > or the Reverse\_JOG\_frequency/Reverse\_JOG\_speed <2.rJoG> is displayed again.



Display after changing the forward JOG



Display after changing the reverse JOG

**6. Press the [MONI/FNC] key.**

- The [FNC] LED turns off, after a monitor item is displayed for about one second, its data appears.

**7. Press the [JOG/→] key.**

- Forward JOG operation starts, and frequency/speed changes until it reaches the setting value of the Forward\_JOG\_frequency/Forward\_JOG\_speed.
- Press the [FWD/REV] key and then the [JOG/→] key to start reverse JOG operation. Then, the frequency/speed changes until it reaches the setting value of the Reverse\_JOG\_frequency/Reverse\_JOG\_speed
- While the inverter is in operation, the currently set monitor item data is displayed.
- You can change forward or reverse JOG frequency/speed while the inverter is running.



"2.0" Hz displayed as current output frequency in [V/f]

**8. Release the [JOG/→] key.**

- JOG operation stops.



"0.0" Hz displayed as output frequency when the inverter is stopped in [V/f]

[V/f] Setting range, Initialized data, and unit of JOG frequency

Display	Contents	Setting range	Initialized data	Unit	Driving ReWrite
1.FJoG	Forward_JOG_fre- quency	Minimum_frequency <A-01> to 30.0	1.0	Hz	○
2.rJoG	Reverse_JOG_fre- quency	-30.0 to -Minimum_frequency <A-01>	-1.0	Hz	○

[IM] [EDM] Setting range, Initialized data, and unit of JOG speed

Display	Contents	Setting range	Initialized data	Unit	Driving ReWrite
1.FJoG	Forward_JOG_speed	Minimum_speed <A-01> to 300	24	r/min	○
2.rJoG	Reverse_JOG_speed	-300 to -Minimum_speed <A-01>	-24	r/min	○

For details of the Minimum\_frequency/Minimum\_speed <A-01>, refer to {5.3.2 Area A}.

#### 4.4.6 Changing JOG Acceleration or Deceleration Time

To change JOG acceleration or deceleration time, perform the following steps on the console:

The parameters to be changed are the Acceleration\_time(2) <5.Acc2> and Deceleration\_time(2) <6.dEc2>. For details of how to change parameter settings, refer to {4.1.3 Changing Parameter Settings}.

##### 1. When the [FNC] LED on the console turns off, press the [MONI/FNC] key.

- The [FNC] LED turns on, and a setting item appears in the seven-segment display. For example, immediately after the inverter is turned on, the first item of the basic setting area is displayed.

##### 2. Press the keys [↑] and [↓] to display "5.Acc2" (Acceleration\_time(2)) or "6.dEc2" (Deceleration\_time(2)).

- To change acceleration time, select "5.Acc2." To change deceleration time, select "6.dEc2."
- This parameter is common to [V/f], [IM], and [EDM].
- For details of the Acceleration\_time(2) <5.Acc2> and Deceleration\_time(2) <6.dEc2>, refer to {5.3.1 Basic Setting Area}.



When changing JOG acceleration time



When changing JOG deceleration time

**3. Press the [SET] key.**

- The selection of the setting item is confirmed, a current setting value is displayed.
- The display of the setting value automatically returns to that of the setting item in ten seconds. Unless a setting value is specified while it is displayed, it cannot be changed.



"0.3" indicates Initialized data (sec) of the Acceleration\_time(2)

**4. Press the [JOG/→] key to blink a required digit, and then press the keys [↑] and [↓] to change the number (acceleration or deceleration time).**

- The setting range is 0.0 to 3600.0 sec.



Acceleration time changed to "1.0" sec

**5. Press the [SET] key.**

- The display of the setting value automatically returns to that of the setting item in ten seconds. Unless the [SET] key is pressed while a setting value is displayed, the change cannot be confirmed.
- The change is confirmed, and "5.Acc2" (Acceleration\_time(2)) or "6.dEc2" (Deceleration\_time(2)) is displayed again.



Display after changing the acceleration time



Display after changing the deceleration time

**6. Press the [MONI/FNC] key.**

- The [FNC] LED turns off, after a monitor item is displayed for about one second, its data appears.

**7. Press the [JOG/→] key.**

- JOG operation starts, and the inverter accelerates or decelerates until it reaches the specified value of acceleration or deceleration time.
- While it operates, the currently set monitor item data is displayed.
- You can change acceleration or deceleration time while the inverter is running.



"2.0" Hz displayed as current output frequency in [V/f]

**8. Release the [JOG/→] key.**

- JOG operation stops.



"0.0" Hz displayed as output frequency when the inverter is stopped in [V/f]

Setting range, Initialized data, and unit of JOG acceleration or deceleration time

Display	Contents	Setting range	Initialized data	Unit	Driving ReWrite
5.Acc2	Acceleration_time(2)	0.0 to 3600.0	0.3	sec	○
6.dEc2	Deceleration_time(2)	0.0 to 3600.0	0.3	sec	○

## 4.5 Start and Stop through External Contact in V/f Control

In [V/f], you can start and stop the inverter by installing an external contact, in addition to using the [START] key and the [STOP/RESET] key on the console.

Connect the external contact to the control input terminal [ST-F] of the terminal block <TB1> on the control board <VFC66-Z>.

This section provides a configuration and operating procedures for installing the external contact to start and stop the inverter.

### ■ Checking jumper socket position

Check the position of the jumper socket for a jumper pin next to the terminal block <TB1> on the control board <VFC66-Z>.

- When it is positioned at [CN-SO], this indicates PS common input (source input).
- When it is positioned at [CN-SI], this indicates GND common input (sink input).

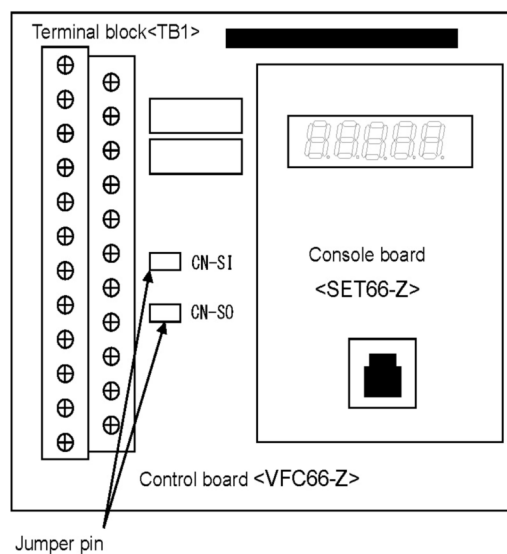

### 1. Turn off the inverter.

### 2. Open the front cover.

- For how to open the front cover, refer to {3.2 How to Open and Close Front Cover}.
- Use the Phillips screwdriver (M4).

### 3. Check the position of the jumper socket for a jumper pin.

### 4. Close the front cover.

### ■ Installing the external contact and changing settings

This section provides procedures for installation and settings when the jumper socket is positioned at [CN-SO] (PS common input).

When it is positioned at [CN-SI] (GND common input), you should replace a terminal [PS] with a terminal [GND] in the procedures.

The parameter to be changed is the Operation\_command\_input\_selection <b-11>.

For details of how to change parameter settings, refer to {4.1.3 Changing Parameter Settings}.

## **WARNING** Installation of the external contact

- Be sure to turn off the inverter before installing the external contact.  
It may result in a risk of electric shock.
- Be sure to turn off the external contact to be installed.  
If it is installed with it turned on, the motor may suddenly start when the inverter is turned on.

### Items to prepare

- Phillips screwdriver (M3)
- Phillips screwdriver (M4)
- External contact

### 1. Turn off the inverter.

### 2. Open the front cover.

- For how to open the front cover, refer to {3.2 How to Open and Close Front Cover}.
- Use the Phillips screwdriver (M4).

### 3. Install the external contact between the control input terminal [ST-F] and the terminal [PS] of the terminal block on the control board <VFC66-Z>.

- For the terminal block and the position of terminals, refer to {3.3.1 How to Connect Inverter Terminals}.
- Use the Phillips screwdriver (M3).

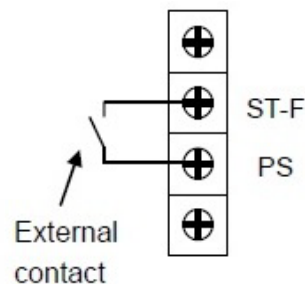

### 4. Close the front cover and turn on the inverter.

### 5. When the [FNC] LED on the console turns off, press the [MONI/FNC] key.

- The [FNC] LED turns on, and a setting item appears in the seven-segment display. For example, immediately after the inverter is turned on, the first item of the basic setting area is displayed.

### 6. Press the keys [↑] and [↓] to display "b-00."



**7. Press the [JOG/→] key to blink numbers, and then press the keys [↑] and [↓] to change them to become "b-11."**

- For details of the Operation\_command\_input\_selection <b-11>, refer to {5.3.3 Area b}.



**8. Press the [SET] key.**

- The selection of "b-11" is confirmed, a current setting value ("0" to "3") is displayed. In default, "0" (Interlocked) is displayed.
- The display of the setting value automatically returns to that of the setting item in ten seconds. Unless a setting value is specified while it is displayed, it cannot be changed.



**9. Press the keys [↑] and [↓] to change the number to "1" (Terminal block).**



**10. Press the [SET] key.**

- The change is confirmed, and "b-11" is displayed again.
- The display of the setting value automatically returns to that of the setting item in ten seconds. Unless the [SET] key is pressed while a setting value is displayed, the change cannot be confirmed.



**11. Press the [MONI/FNC] key.**

- The [FNC] LED turns off, after a monitor item is displayed for about one second, its data appears.

12. Turn on the installed external contact to start operation, and turn it off to stop operation.

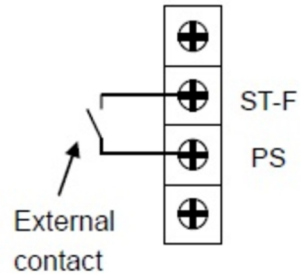

**⚠ WARNING** Using the external contact

- When you turn on the power with signals input in the control input terminal [ST-F] on the terminal block, the motor suddenly restarts. After checking that no signal is input in the terminal [ST-F], turn on the power.

## 4.6 Changing Speed through Voltage Setting Device/Variable Resistor in V/f Control

In [V/f], you can change a frequency command and speed of the motor by installing a voltage setting device/variable resistor, in addition to setting frequency with the Frequency\_command <0.FrEF>.

Connect the voltage setting device/variable resistor among the terminals [+10], [AIN1], and [GND] on the control board <VFC66-Z>. Install the variable resistor with a resistance of around 10 k-ohm.

This section provides a configuration and operating procedures for installing the voltage setting device/variable resistor to change a frequency command and speed of the motor.

### ■ Installing the voltage setting device/variable resistor and changing settings

The parameter to be changed is the Frequency\_command\_input\_selection <b-10>.

For details of how to change parameter settings, refer to {4.1.3 Changing Parameter Settings}.

### **WARNING** Installation of the voltage setting device/variable resistor

- Be sure to turn off the inverter before installing the voltage setting device/variable resistor.

It may result in a risk of electric shock.

- When installing the voltage setting device/variable resistor, be sure to keep the minimum resistance value between the terminals [AIN1] and [GND].

Turning on the inverter may cause the motor to suddenly start.

### Items to prepare

- Phillips screwdriver (M3)
- Phillips screwdriver (M4)
- Variable resistor (a resistance of around 10 k-ohm) or voltage setting device

#### 1. Turn off the inverter.

#### 2. Open the front cover.

- For how to open the front cover, refer to {3.2 How to Open and Close Front Cover}.
- Use the Phillips screwdriver (M4).

#### 3. Install the variable resistor or the voltage setting value among the terminals [+10], [AIN1], and [GND] on the control board <VFC66-Z>.

- For the terminal block and the position of terminals, refer to {3.3.1 How to Connect Inverter Terminals}.
- Use the Phillips screwdriver (M3).

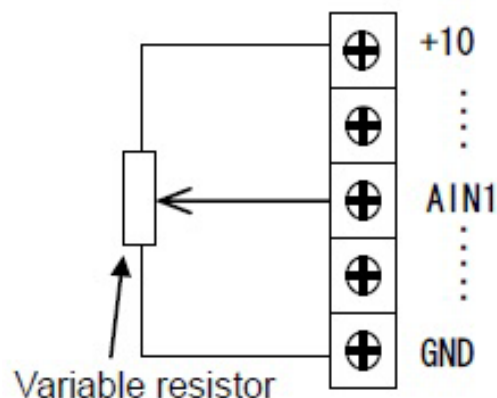

#### 4. Close the front cover and turn on the inverter.

**5. When the [FNC] LED on the console turns off, press the [MONI/FNC] key.**

- The [FNC] LED turns on, and a setting item appears in the seven-segment display. For example, immediately after the inverter is turned on, the first item of the basic setting area is displayed.

**6. Press the keys [↑] and [↓] to display "b-00."****7. Press the [JOG/→] key to blink numbers, and then press the keys [↑] and [↓] to change them to become "b-10."**

- For details of the Frequency\_command\_input\_selection <b-10>, refer to {5.3.3 Area b}.

**8. Press the [SET] key.**

- The selection of "b-10" is confirmed, a current setting value ("0" to "7") is displayed. In default, "0" (Interlocked) is displayed.
- The display of the setting value automatically returns to that of the setting item in ten seconds. Unless a setting value is specified while it is displayed, it cannot be changed.

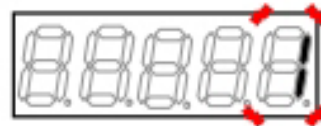
**9. Press the keys [↑] and [↓] to change the number to "1" (Terminal block).****10. Press the [SET] key.**

- The change is confirmed, and "b-10" is displayed again.
- The display of the setting value automatically returns to that of the setting item in ten seconds. Unless the [SET] key is pressed while a setting value is displayed, the change cannot be confirmed.

**11. Press the [MONI/FNC] key.**

- The [FNC] LED turns off, after a monitor item is displayed for about one second, its data appears.

**12. When the variable resistor or the voltage setting device regulates, a value of a frequency command will change.**

## Chapter 5 Explanation of Parameters

### 5.1 List of Parameters That Can Be Changed in Simple Mode

The table below lists the parameters that can be changed in the "simple mode."

To display and change all the parameters, you should change the mode to the "full mode." For how to change to the "full mode," refer to {4.1.4 Changing Parameter Simple Mode and Full Mode}.

The symbols in the Driving ReWrite field on the right in the table have the following meanings:

○: ReWrite is possible, ×: ReWrite is not possible

#### 5.1.1 V/f Control

Basic setting area

Display	Setting item	Setting range	Initialized data	Unit	Driving ReWrite
0.FrEF	Frequency_command	-Maximum_frequency to +Maximum_frequency	0.5	Hz	○
1.FJoG	Forward_JOG_frequency	Minimum_frequency to 30.0	1.0	Hz	○
2.rJoG	Reverse_JOG_frequency	-30.0 to -Minimum_frequency	-1.0	Hz	○
3.Acc1	Acceleration_time(1)	0.0 to 3600.0	30.0	sec	○
4.dEc1	Deceleration_time(1)				
5.Acc2	Acceleration_time(2)	0.0 to 3600.0	0.3	sec	○
6.dEc2	Deceleration_time(2)				
7.tbSt	Torque_boost_amount	0.0 to 20.0	0.0	%	○
8.dcbr	DC_brake_voltage	0.0 to 20.0	0.0	%	○
9.Stb	Stabilizer_amount	0.0 to 100.0	0.0	%	○

## Area A (setting area for maximum frequency, rated motor, and other parameters)

Display	Setting item	Setting range or selecting item	Initialized data	Unit	Driving ReWrite
A-00	Maximum_frequency	15.0 to 400.0	60.0	Hz	×
A-01	Minimum_frequency	0. to 10.0	0.5	Hz	○
A-02	Rated_motor_capacity	0 to Rated capacity of the inverter <sup>*1</sup>	Inverter rating <sup>*3</sup>	kW	×
A-03	Rated_motor_voltage	[200 V class] 70 to 230	200	V	×
		[400 V class] 140 to 460	400		
A-04	Rated_motor_current	20 to 150 % of the rated inverter current	Inverter rating <sup>*3</sup>	A	×
A-05	Rated_motor_speed	400 to 24000	1760	r/min	×
A-06	Number_of_motor_pole	2 to 12	4	Pole	×
A-07	Rated_motor_fre- quency	15.0 to Maximum_frequency <A-00>	60.0	Hz	×
A-08	—	—	—	—	—
A-09	PWM_carrier_fre- quency	1.0 to 6.0	2.0	kHz	×
A-10	—	—	—	—	—
A-11	DeadTime_compensation(T1/U_phase posi- tive side)	0.00 to 9.99	Value depending on the rated inverter <sup>*2</sup>	μ sec	×
A-12	DeadTime_compensation(T1/U_phase nega- tive side)				
A-13	DeadTime_compensation(T2/V_phase posi- tive side)				
A-14	DeadTime_compensation(T2/V_phase nega- tive side)				
A-15	DeadTime_compensation(T3/W_phase posi- tive side)				
A-16	DeadTime_compensation(T3/W_phase nega- tive side)				
A-17	Motor_primary_resist- ance	(The Setting range depends on the rated inverter) <sup>*2</sup>	Value depending on the rated inverter <sup>*2</sup>	m Ω	×

- \* 1: When the rated motor voltage is larger than 190 V [200 V class] or 380 V [400 V class], the maximum value in the setting range becomes larger proportional to that voltage.  
[200 V class] Maximum value of <A-02> = (Rated capacity of the inverter) × <A-03>/190V  
[400 V class] Maximum value of <A-02> = (Rated capacity of the inverter) × <A-03>/380V
- \* 2: As shown in the table below, the Initialized data of <A-11> through <A-17> and the setting range of <A-17> depend on the inverter model.
- \* 3: For Initialized data of <A-02> and <A-04>, the position of its decimal point depends on the inverter capacity.

Initialized data of <A-11> through <A-17> and Setting range of <A-17>

Inverter model	Initialized data		Setting range	Inverter model	Initialized data		Setting range
	<A-11> to <A-16>	<A-17>	<A-17>		<A-11> to <A-16>	<A-17>	<A-17>
2R222	4.00	626	1 to 65535	2R244	4.00	2566	1 to 65535
3R722	4.00	469.9	0. to 6553.5	3R744	4.00	1880	
5R522	4.00	228.8		5R544	4.00	915	
7R522	4.00	186.8		7R544	4.00	747.3	0.1 to 6553.5
1122	2.80	94.0	1144	2.80	376.0		
1522	2.80	76.6	1544	2.80	306.2		
2222	2.80	34.00	0.01 to 655.35	2244	2.80	136.0	
3022	2.80	25.80		3044	2.80	103.2	
3722	2.80	20.10		3744	2.80	80.4	
4522	2.80	15.40		4544	2.80	61.50	0.01 to 655.35
5522	2.80	10.80		5544	2.80	43.30	
7522	2.80	7.00		7544	2.80	28.00	
9022	2.80	5.30	11044	2.80	14.60		
15022	2.80	2.812	0.001 to 65.535	16044	2.80	7.80	
18022	2.80	1.743		20044	2.80	6.20	
				25044	2.80	4.92	0.001 to 65.535
				31544	2.80	3.33	
				40044	2.80	2.633	
				50044	2.80	1.782	
			60044	2.80	1.206		
			75044	2.80	0.820		
			100044	2.80	0.645		

## Area b (setting area for operation mode and operation sequence)

Display	Setting item	Setting range or selecting item	Initialized data	Unit	Driving ReWrite
b-00	Setting_data_rewrite_protection	OFF: Without protection ON: With protection	OFF	—	×
b-01	Stop_mode_selection	0: Free stop 1: Deceleration stop 2: Deceleration stop with DC brake	1	—	○
b-02	Stop_frequency	0.0 to 30.0	1.0	Hz	○
b-03	DC_brake_operation_time	0.0 to 10.0	0.0	sec	○
b-04	—	—	—	—	—
b-05	JOG_stop_mode_selection	0: Free stop 1: Deceleration stop 2: Deceleration stop with DC brake	0	—	○
b-06	JOG_stop_frequency	0.0 to 10.0	1.0	Hz	○
b-07	Instantaneous_power_interruption_restart	OFF: Not restart ON: Restart	OFF	—	×
b-08	Reverse_prohibition_mode_selection	0: Normal 1: Reverse prohibition against command 2: Reverse prohibition	0	—	×
b-09	Command_input_when_coupled	0: Terminal block 1: Console 2: Digital communication option	1	—	×
b-10	Frequency_command_input_selection	0: Interlocked 1: Analog input (1) terminal [AIN1] 2: Console 3: Digital communication option 4: Analog input (2) or digital communication option terminal [AIN2] 5: Digital setting input option 6: Analog input (3) terminal [AIN3] 7: Internal PLC	0	—	×
b-11	Operation_command_input_selection	0: Interlocked	0	—	×
b-12	JOG-command_input_selection	1: Terminal block 2: Console 3: Digital communication option			

Display	Setting item	Setting range or selecting item	Initialized data	Unit	Driving ReWrite
b-13	Powering_torque_limit	0 to 150 (The Setting range changes from 0 to up to 200 % depending on the motor)	150	%	○
b-14	Regenerative_torque_limit	-150 to 0 (The Setting range changes from -200 to up to 0 % depending on the motor)	-150	%	○
b-15	Powering_torque_limit_usage_selection	OFF: Unused	ON:	—	×
b-16	Regenerative_torque_limit_usage_selection	ON: Used			
b-17	Analog_frequency_command_characteristic_selection	0: 0 to ±10 V 1: 0 to 10 V 2: 4 to 20 mA	1	—	×
b-18	Analog_frequency_command_upper_limit_frequency	Absolute value of Analog_frequency_command_lower_limit_frequency to 100.0	100.0	%	○
b-19	Analog_frequency_command_lower_limit_frequency	-Analog_frequency_command_upper_limit_frequency to +Analog_frequency_command_upper_limit_frequency	0.0	%	○
b-20	Analog_input_ZeroLimit_voltage	0.000 to 1.000	0.000	V	○
b-21	Analog_output(1)_characteristics_selection	0: Output voltage 1: Output current 2: Output torque 3: Frequency 4: Frequency command 5: Internal PLC output 6: Calibration 7: Monitor for adjustment ----- -1: 6F frequency -2: 6F speed -3: 6F calibration	1	—	×

## Area S (inverter control method selection, Autotuning)

Display	Setting item	Setting range or selecting item	Initialized data	Unit	Driving ReWrite
S-00	Special_mode_selection	1: Initialize the inverter 2: Change the inverter control method 3: Clear protections 4: Switch the simple mode and full mode 12: Direct Current Mode Autotuning (forward) 13: Direct Current Mode Autotuning (reverse) 99: Initialize the inverter (for special adjustment)* 101: Data transfer to <SET66EX-Z> 102: Copy data from <SET66EX-Z> (without area A) 103: Copy data from <SET66EX-Z> (with area A) 104: Compare data with <SET66EX-Z>	—	—	○
S-01	Timer_remaining_time1_clear	1: Clear the Timer_remaining_time1	—	—	○
S-02	Timer_remaining_time2_clear	1: Clear the Timer_remaining_time2	—	—	○

\* This is for special adjustment only. Do not use it usually.

## 5.1.2 Induction Motor Vector Control

### Basic setting area

Display	Setting item	Setting range	Initialized data	Unit	Driving ReWrite
0.SrEF	Speed_command	-Maximum_speed <A-00> to +Maximum_speed <A-00>	0	r/min	○
1.FJoG	Forward_JOG_speed	Minimum_speed <A-01> to 300	24	r/min	○
2.rJoG	Reverse_JOG_speed	-300 to -Minimum_speed <A-01>	-24	r/min	○
3.Acc1	Acceleration_time(1)	0.0 to 3600.0	30.0	sec	○
4.dEc1	Deceleration_time(1)				
5.Acc2	Acceleration_time(2)	0.0 to 3600.0	0.3	sec	○
6.dEc2	Deceleration_time(2)				
7.ASrP	Speed_control_pro- portion_gain(1)	1 to 50	15	—	○
8.ASrI	Speed_control_inte- gral_time_constant(1)	20 to 10000	40	msec	○
9.ASrJ	System_inertia_mo- ment(1)	0 to 65535	10	gm <sup>2</sup>	○

### Area A (setting area for maximum frequency, rated motor, and other parameters)

Display	Setting item	Setting range or selecting item	Initialized data	Unit	Driving ReWrite
A-00	Maximum_speed	300 to 14700	1800	r/min	×
A-01	Minimum_speed	0 or 12 (value depending on the setting of *2) to Maximum_speed	12	r/min	○
A-02	Rated_motor_capacity	Value depending on the inverter*3 to Rated capacity of the inverter*1	0.00*4	kW	×
A-03	Rated_motor_voltage	[200 V class] 70 to 230	0	V	×
		[400 V class] 140 to 460			
A-04	Rated_motor_current	20 to 150 % of the rated inverter current	0.00*4	A	×
A-05	Rated_motor_speed	20 to 100 % of Maximum_speed	0	r/min	×
A-06	Number_of_motor_pole	2 to 12	4	Pole	×
A-07	Rated_motor_fre- quency	(Rated speed x Number of poles/120) to (Rated speed x Number of poles/120 + 7.0)	0.0	Hz	×
A-08	Number_of_PG-pulse	60 to 32767	600	P/R	×
A-09	PWM_carrier_fre- quency	1.0 to 6.0	6.0	kHz	×
A-10	PG_selection	0: S mode drive without sensor 1: V mode with PG (A,B phase input) drive	0	—	×

Display	Setting item	Setting range or selecting item	Initialized data	Unit	Driving ReWrite
A-11	DeadTime_compensation(T1/U_phase positive side)	0.00 to 9.99	0.00	μsec	×
A-12	DeadTime_compensation(T1/U_phase negative side)				
A-13	DeadTime_compensation(T2/V_phase positive side)				
A-14	DeadTime_compensation(T2/V_phase negative side)				
A-15	DeadTime_compensation(T3/W_phase positive side)				
A-16	DeadTime_compensation(T3/W_phase negative side)				
A-17	Motor_primary_resistance	(The Setting range depends on the inverter capacity)* <sup>3</sup>	0.0* <sup>4</sup>	mΩ	×
A-18	Motor_secondary_resistance				
A-19	Motor_leakage_inductance	(The Setting range depends on the inverter capacity)* <sup>3</sup>	0.0* <sup>4</sup>	mH	×
A-20	Motor_mutual_inductance				
A-21	Motor_inductance_saturation_coefficient (1)	0.0 to 50.0	0.0	%	×
A-22	Motor_inductance_saturation_coefficient (2)				
A-23	Motor_core_loss_torque_compensation	0.0 to 20.0	0.0	%	×
A-24	Motor_loss_coefficient (1)	0.0 to 200.0	0.0	%	×
A-25	Motor_loss_coefficient (2)				

- \* 1: When the rated motor voltage is larger than 190 V [200 V class] or 380 V [400 V class], the maximum value in the setting range becomes larger proportional to that voltage.  
 [200 V class] Maximum value of <A-02> = (Rated capacity of the inverter) × <A-03>/190V  
 [400 V class] Maximum value of <A-02> = (Rated capacity of the inverter) × <A-03>/380V
- \* 2: The minimum value in the setting range of <A-01> becomes "12" when "0" (S mode) is set to <A-10>, and "0" when "1" (V mode) is set to <A-10>.
- \* 3: As shown in the tables below, the minimum value in the setting range of <A-02>, the setting range of <A-17> and <A-18>, and the setting range of <A-19> and <A-20> depend on the inverter model.
- \* 4: For Initialized data of <A-02>, <A-04>, and <A-17> through <A-20>, the position of its decimal point depends on the inverter capacity.

Minimum value in Setting range of &lt;A-02&gt;

Inverter model	<A-02>	Inverter model	<A-02>
2R222	0.75	2R244	0.75
3R722	1.10	3R744	1.10
5R522	1.50	5R544	1.50
7R522	2.20	7R544	2.20
1122	3.70	1144	3.70
1522	5.50	1544	5.50
2222	7.50	2244	7.50
3022	11.00	3044	11.00
3722	15.00	3744	15.00
4522	22.0	4544	22.0
5522	30.0	5544	30.0
7522	37.0	7544	37.0
9022	45.0	11044	45.0
15022	55.0	16044	55.0
18022	75.0	20044	75.0
		25044	110.0
		31544	160.0
		40044	200.0
		50044	250.0
		60044	315.0
		75044	400.0
		100044	500.0

Setting range of &lt;A-17&gt; through &lt;A-20&gt;

Inverter model	<A-17> <A-18>	<A-19> <A-20>	Inverter model	<A-17> <A-18>	<A-19> <A-20>
2R222	1 to 65535	0.1 to 3276.7	2R244	1 to 65535	0.1 to 3276.7
3R722	0.1 to 6553.5	0.01 to 327.67	3R744	0.1 to 6553.5	0.01 to 327.67
5R522			5R544		
7R522			7R544		
1122			1144		
1522			1544		
2222			2244		
3022	0.01 to 6553.5	0.001 to 32.767	3044	0.01 to 6553.5	0.001 to 32.767
3722			3744		
4522			4544		
5522			5544		
7522			7544		
9022			11044		
15022	0.001 to 65.535	0.001 to 32.767	16044	0.001 to 65.535	0.001 to 32.767
18022			20044		
			25044		
			31544		
			40044		
			50044		
	60044	0.001 to 65.535		0.001 to 65.535	0.001 to 32.767
	75044				
			100044		

## Area b (setting area for operation mode and operation sequence)

Display	Setting item	Setting range or selecting item	Initialized data	Unit	Driving ReWrite
b-00	Setting_data_rewrite_protection	OFF: Without protection ON: With protection	OFF	—	×
b-01	Stop_mode_selection	0: Free stop 1: Deceleration stop 2: Deceleration stop with DC brake	1	—	○
b-02	Stop_speed	0 to 300	30	r/min	○
b-03	DC_brake_operation_time	0.0 to 10.0	0.0	sec	○
b-04	DC_brake_gain	20.0 to 500.0	100.0	%	○
b-05	JOG_stop_mode_selection	0: Free stop 1: Deceleration stop 2: Deceleration stop with DC brake	0	—	○
b-06	JOG_stop_speed	0 to 300	30	r/min	○
b-07	Instantaneous_power_interruption_restart	OFF: Not restart ON: Restart	OFF	—	×
b-08	Reverse_prohibition_mode_selection	0: Normal 1: Reverse prohibition against command 2: Reverse prohibition	0	—	×
b-09	Command_input_when_coupled	0: Terminal block 1: Console 2: Digital communication option	1	—	×
b-10	Speed_command_input_selection	0: Interlocked 1: Analog input (1) terminal [AIN1] 2: Console 3: Digital communication option 4: Analog input (2) <IO66-Z> or digital communication option terminal [AIN2] 5: Digital setting input option <BCD66-Z> 6: Analog input (3) <IO66-Z> terminal [AIN3] 7: Internal PLC	0	—	×

Display	Setting item	Setting range or selecting item	Initialized data	Unit	Driving ReWrite
b-11	Operation_command_input_selection	0: Interlocked	0	—	×
b-12	JOG-command_input_selection	1: Terminal block 2: Console 3: Digital communication option			
b-13	Forward_powering_torque_limit	0 to Value depending on the Rated_motor_current <A-04>*1	150	%	○
b-14	Forward_regenerative_torque_limit	Value depending on -Rated_motor_current <A-04>*1 to 0	-150	%	○
b-15	Reverse_powering_torque_limit	Value depending on -Rated_motor_current <A-04>*1 to 0	-150	%	○
b-16	Reverse_regenerative_torque_limit	0 to Value depending on the Rated_motor_current <A-04>*1	150	%	○
b-17	Analog_speed_command_characteristic_selection	0: 0 to ±10 V 1: 0 to 10 V 2: 4 to 20 mA	1	—	×
b-18	Analog_speed_command_upper_limit_speed	Absolute value of Analog_speed_command_lower_limit_speed <b-19> to 100.0	100.0	%	○
b-19	Analog_speed_command_lower_limit_speed	-Analog_speed_command_upper_limit_speed <b-18> to +Analog_speed_command_upper_limit_speed <b-18>	0.0	%	○
b-20	Analog_input_ZeroLimit_voltage	0.000 to 1.000	0.000	V	○
b-21	Analog_output(1)_characteristics_selection	0: Output voltage 1: Output current 2: Torque command 3: Speed 4: Speed command 5: Internal PLC output 6: Calibration 7: Monitor for adjustment ----- -1: 6F frequency -2: 6F speed -3: 6F calibration	1	—	×

\* 1: The maximum (minimum) value of torque limit is calculated for VF66B-2R222 through 5522 and 2R244 through 5544 as follows:

$$200 \times (\text{Rated inverter current}) / \text{Rated\_motor\_current} \langle \text{A-04} \rangle$$

(However, when the calculated value exceeds 200 %, it should be 200 %)

It is calculated for VF66B-7522 through 18022 and 7544 through 100044 as follows:  
 $150 \times (\text{Rated inverter current}) / \text{Rated\_motor\_current} \langle \text{A-04} \rangle$   
 (However, when the calculated value exceeds 200 %, it should be 200 %)

Area S (inverter control method selection, Autotuning)

Display	Setting item	Setting range or selecting item	Initialized data	Unit	Driving ReWrite
S-00	Special_mode_selection	1: Initialize the inverter 2: Change the inverter control method 3: Clear protections 4: Switch the simple mode and full mode 10: Full Mode Autotuning (forward) 11: Full Mode Autotuning (reverse) 12: Direct Current Mode Autotuning (forward) 13: Direct Current Mode Autotuning (reverse) 99: Initialize the inverter (for special adjustment)* 101: Data transfer to $\langle \text{SET66EX-Z} \rangle$ 102: Copy data from $\langle \text{SET66EX-Z} \rangle$ (without area A) 103: Copy data from $\langle \text{SET66EX-Z} \rangle$ (with area A) 104: Compare data with $\langle \text{SET66EX-Z} \rangle$	—	—	○
S-01	Timer_remaining_time1_clear	1: Clear the Timer_remaining_time1	—	—	○
S-02	Timer_remaining_time2_clear	1: Clear the Timer_remaining_time2	—	—	○

\* This is for special adjustment only. Do not use it usually.

### 5.1.3 ED Motor Vector Control

Basic setting area

Display	Setting item	Setting range	Initialized data	Unit	Driving ReWrite
0.SrEF	Speed_command	-Maximum_speed <A-00> to +Maximum_speed <A-00>	0	r/min	○
1.FJoG	Forward_JOG_speed	Minimum_speed <A-01> to 300	24	r/min	○
2.rJoG	Reverse_JOG_speed	-300 to -Minimum_speed <A-01>	-24	r/min	○
3.Acc1	Acceleration_time(1)	0.0 to 3600.0	30.0	sec	○
4.dEc1	Deceleration_time(1)				
5.Acc2	Acceleration_time(2)	0.0 to 3600.0	0.3	sec	○
6.dEc2	Deceleration_time(2)				
7.ASrP	Speed_control_pro- portion_gain(1)	1 to 50	15	—	○
8.ASrI	Speed_control_inte- gral_time_constant(1)	20 to 10000	40	msec	○
9.ASrJ	System_inertia_mo- ment(1)	0 to 65535	10	gm <sup>2</sup>	○

Area A (setting area for maximum frequency, rated motor, and other parameters)

Display	Setting item	Setting range or selecting item	Initialized data	Unit	Driving ReWrite
A-00	Maximum_speed	300 to 20000	1800	r/min	×
A-01	Minimum_speed	0 to Maximum_speed <A-00>	0	r/min	○
A-02	Rated_motor_capacity	Value depending on the inverter*2 to 150 % of the rated capacity of the inverter*1	0.00*5	kW	×
A-03	Rated_motor_voltage	[200 V class] 70 to 230	0	V	×
		[400 V class] 140 to 460			
A-04	Rated_motor_current	20 to 150 % of the rated inverter current	0.0*5	A	×
A-05	Rated_motor_speed	20 to 100 % of Maximum_speed <A-00>	0	r/min	×
A-06	Number_of_motor_pole	2 to 64	6	Pole	×
A-07	Motor_q-axis_pulse_pole_determination_current	0 to 200 (ratio to the rated motor current) (It is always unchangeable in the P mode)	50	%	×
A-08	Number_of_PG_pulse*3	60 to 32767*4	600	P/R	×
A-09	PWM_carrier_frequency	1.0 to 6.0	6.0	kHz	×
A-10	PG_selection	0: S mode drive without sensor 1: V mode with PG (A,B,Z phase input) drive 2: P mode with PG (A,B,U,V,W phase input) drive 3: RL mode with resolver drive (Resolution 10 bit) 4: RH mode with resolver drive (Resolution 12 bit)	0	—	×
A-11	DeadTime_compensation(T1/U_phase positive side)	0.00 to 9.99	0.00	μsec	×
A-12	DeadTime_compensation(T1/U_phase negative side)				
A-13	DeadTime_compensation(T2/V_phase positive side)				
A-14	DeadTime_compensation(T2/V_phase negative side)				
A-15	DeadTime_compensation(T3/W_phase positive side)				
A-16	DeadTime_compensation(T3/W_phase negative side)				

Display	Setting item	Setting range or selecting item	Initialized data	Unit	Driving ReWrite
A-17	Motor_primary_resistance	(The Setting range depends on the rated inverter)*2	0.0*5	mΩ	×
A-18	Motor_d-axis_inductance	(The Setting range depends on the rated inverter)*2	0.0*5	mH	×
A-19	Motor_q-axis_inductance				
A-20	Motor_magnetic_flux	0.000 to 9.999	0.000	Wb	×
A-21	Motor_core_loss_torque_compensation	0.0 to 0.0	0.0	%	×
A-22	Lq-change_rate_at_30%_motor_q-axis_current	-100.0 to 100.0	0.0	%	×
A-23	Lq-change_rate_at_60%_motor_q-axis_current				
A-24	Lq-change_rate_at_90%_motor_q-axis_current				
A-25	Lq-change_rate_at_120%_motor_q-axis_current				
A-26	Ld-change_rate_at_30%_motor_d-axis_current	-100.0 to 100.0	0.0	%	×
A-27	Ld-change_rate_at_60%_motor_d-axis_current				
A-28	Ld-change_rate_at_90%_motor_d-axis_current				
A-29	Ld-change_rate_at_120%_motor_d-axis_current				
A-30	Motor_d-axis_position	0 to 30000 ("−1" indicates that a value is not set) ("0" specified in <A-10> is always unchangeable in the S mode)	−1	—	×
A-31	Pole_determination_selection	0: Motor q-axis determination by pulse (1) 1: Motor q-axis determination by pulse (2) 2: Motor d-axis determination by pulse	0	—	×

Display	Setting item	Setting range or selecting item	Initialized data	Unit	Driving ReWrite
A-32	Motor_d-axis_measurement_pulse_width	-12.7 to 12.7	0.0	msec	×
A-33	Motor_d-axis_measurement_pulse_voltage_amplitude	0: 30 % 1: 50 % 2: 75 % 3: 100 % 4: 7 % 5: 9.5 % 6: 12 % 7: 20 %	0	—	×

- \* 1: When the rated motor voltage is larger than 190 V [200 V class] or 380 V [400 V class], the maximum value in the setting range becomes larger proportional to that voltage.  
[200 V class] Maximum value of <A-02> = (Rated capacity of the inverter) × <A-03>/190V  
[400 V class] Maximum value of <A-02> = (Rated capacity of the inverter) × <A-03>/380V
- \* 2: For the minimum value in the setting range of <A-02>, refer to {5.1.2 Induction Motor Vector Control}. For the setting range of <A-17>, <A-18>, and <A-19>, refer to the next table.
- \* 3: When "0" (S mode drive without sensor) is set to <A-10>, the Number\_of\_PG-pulse is not available.
- \* 4: When "3" (RL mode with resolver drive) is set to <A-10>, the maximum value in the setting range becomes 256 x (Number of resolver poles).  
4: When "4" (RH mode with resolver drive) is set to <A-10>, the maximum value in the setting range becomes 256 x (Number of resolver poles) x 4.
- \* 5: For Initialized data of <A-02>, <A-04>, and <A-17> through <A-19>, the position of its decimal point depends on the inverter capacity.

## Setting range of &lt;A-17&gt; through &lt;A-19&gt;

Inverter model	<A-17>	<A-18> <A-19>	Inverter model	<A-17>	<A-18> <A-19>
2R222	1 to 65535	0.1 to 3276.7	2R244	1 to 65535	0.1 to 3276.7
3R722	0.1 to 6553.5	0.01 to 327.67	3R744	0.1 to 6553.5	0.01 to 327.67
5R522			5R544		
7R522			7R544		
1122			1144		
1522			1544		
2222	0.01 to 655.35	0.001 to 32.767	2244	0.01 to 655.35	0.001 to 32.767
3022			3044		
3722			3744		
4522			4544		
5522			5544		
7522			7544		
9022			11044		
15022			16044		
18022	20044	0.001 to 32.767	25044	0.001 to 65.535	
	31544				
	40044				
	50044				
	60044				
	75044				
	100044				

## Area b (setting area for operation mode and operation sequence)

Display	Setting item	Setting range or selecting item	Initialized data	Unit	Driving ReWrite
b-00	Setting_data_rewrite_protection	OFF: Without protection ON: With protection	OFF	—	×
b-01	Stop_mode_selection	0: Free stop 1: Deceleration stop 2: Deceleration stop with DC brake	1	—	○
b-02	Stop_speed	0 to 300	30	r/min	○
b-03	DC_brake_operation_time	0.0 to 10.0	0.0	sec	○
b-04	DC_brake_gain	20.0 to 500.0	100.0	%	○
b-05	JOG_stop_mode_selection	0: Free stop 1: Deceleration stop 2: Deceleration stop with DC brake	0	—	○
b-06	JOG_stop_speed	0 to 300	30	r/min	○
b-07	Instantaneous_power_interruption_restart	OFF: Not restart ON: Restart	OFF	—	×
b-08	Reverse_prohibition_mode_selection	0: Normal 1: Reverse prohibition against command 2: Reverse prohibition	0	—	×
b-09	Command_input_when_coupled	0: Terminal block 1: Console 2: Digital communication option	1	—	×
b-10	Speed_command_input_selection	0: Interlocked 1: Analog input (1) terminal [AIN1] 2: Console 3: Digital communication option 4: Analog input (2) <IO66-Z> or digital communication option terminal [AIN2] 5: Digital setting input option <BCD66-Z> 6: Analog input (3) <IO66-Z> terminal [AIN3] 7: Internal PLC	0	—	×

Display	Setting item	Setting range or selecting item	Initialized data	Unit	Driving ReWrite
b-11	Operation_command_input_selection	0: Interlocked	0	—	×
b-12	JOG-command_input_selection	1: Terminal block 2: Console 3: Digital communication option			
b-13	Forward_powering_torque_limit	0 to Value depending on the Rated_motor_current <A-04>*1	150	%	○
b-14	Forward_regenerative_torque_limit	Value depending on -Rated_motor_current <A-04>*1 to 0	-150	%	○
b-15	Reverse_powering_torque_limit	Value depending on -Rated_motor_current <A-04>*1 to 0	-150	%	○
b-16	Reverse_regenerative_torque_limit	0 to Value depending on the Rated_motor_current <A-04>*1	150	%	○
b-17	Analog_speed_command_characteristic_selection	0: 0 to ±10 V 1: 0 to 10 V 2: 4 to 20 mA	1	—	×
b-18	Analog_speed_command_upper_limit_speed	Absolute value of Analog_speed_command_lower_limit_speed <b-19> to 100.0	100.0	%	○
b-19	Analog_speed_command_lower_limit_speed	-Analog_speed_command_upper_limit_speed <b-18> to +Analog_speed_command_upper_limit_speed <b-18>	0.0	%	○
b-20	Analog_input_ZeroLimit_voltage	0.000 to 1.000	0.000	V	○
b-21	Analog_output(1)_characteristics_selection	0: Output voltage 1: Output current 2: Torque command 3: Speed 4: Speed command 5: Internal PLC output 6: Calibration 7: Monitor for adjustment ----- -1: 6F frequency -2: 6F speed -3: 6F calibration	1	—	×

\* 1: The maximum (minimum) value of torque limit is calculated for VF66B-2R222 through 5522 and 2R244 through 5544 as follows:

$$200 \times (\text{Rated inverter current}) / \text{Rated\_motor\_current} \langle \text{A-04} \rangle$$

(However, when the calculated value exceeds 200 %, it should be 200 %)

It is calculated for VF66B-7522 through 18022 and 7544 through 100044 as follows:  
 $150 \times (\text{Rated inverter current}) / \text{Rated\_motor\_current} \langle \text{A-04} \rangle$   
 (However, when the calculated value exceeds 200 %, it should be 200 %)

Area S (inverter control method selection, Autotuning)

Display	Setting item	Setting range or selecting item	Initialized data	Unit	Driving ReWrite
S-00	Special_mode_selection	1: Initialize the inverter 2: Change the inverter mode 3: Clear protections 4: Switch the simple mode and full mode 10: Full Mode Autotuning (forward) 11: Full Mode Autotuning (reverse) 12: Direct Current Mode Autotuning (forward) 13: Direct Current Mode Autotuning (reverse) 14: Motor D-axis Measurement Mode Autotuning (forward) 15: Motor D-axis Measurement Mode Autotuning (reverse) 16 to 19: For special adjustment* 20: Motor D-axis Measurement Second Mode Autotuning (forward) 21: Motor D-axis Measurement Second Mode Autotuning (reverse) 99: Initialize the inverter (for special adjustment)* 101: Data transfer to $\langle \text{SET66EX-Z} \rangle$ 102: Copy data from $\langle \text{SET66EX-Z} \rangle$ (without area A) 103: Copy data from $\langle \text{SET66EX-Z} \rangle$ (with area A) 104: Compare data with $\langle \text{SET66EX-Z} \rangle$	—	—	○
S-01	Timer_remaining_time1_clear	1: Clear the Timer_remaining_time1	—	—	○
S-02	Timer_remaining_time2_clear	1: Clear the Timer_remaining_time2	—	—	○

\* This is for special adjustment only. Do not use it usually.

## 5.2 List of Parameters in Full Mode

The table below lists a mapping of the seven-segment display and the setting items on the console in the full mode.

For details of each parameter, refer to another manual "Parameter List."

### Basic setting area

Display	[V/f]	Display	[IM]	Display	[EDM]
0.FrEF	Frequency_command	0.SrEF	Speed_command	0.SrEF	Speed_command
1.FJoG	Forward_JOG_fre- quency	1.FJoG	Forward_JOG_speed	1.FJoG	Forward_JOG_speed
2.rJoG	Reverse_JOG_fre- quency	2.rJoG	Reverse_JOG_speed	2.rJoG	Reverse_JOG_speed
3.Acc1	Acceleration_time(1)	3.Acc1	Acceleration_time(1)	3.Acc1	Acceleration_time(1)
4.dEc1	Deceleration_time(1)	4.dEc1	Deceleration_time(1)	4.dEc1	Deceleration_time(1)
5.Acc2	Acceleration_time(2)	5.Acc2	Acceleration_time(2)	5.Acc2	Acceleration_time(2)
6.dEc2	Deceleration_time(2)	6.dEc2	Deceleration_time(2)	6.dEc2	Deceleration_time(2)
7.tbSt	Torque_boost_amount	7.ASrP	Speed_control_proportion_gain (1)	7.ASrP	Speed_control_proportion_gain (1)
8.dabr	DC_brake_voltage	8.ASrI	Speed_control_integral_time_ constant(1)	8.ASrI	Speed_control_integral_time_ constant(1)
9.Stb	Stabilizer_amount	9.ASrJ	System_inertia_moment(1)	9.ASrJ	System_inertia_moment(1)

### Area A (setting area for maximum frequency/maximum speed, rated motor, and other parameters)

Display	[V/f]	[IM]	[EDM]
A-00	Maximum_frequency	Maximum_speed	
A-01	Minimum_frequency	Minimum_speed	
A-02	Rated_motor_capacity		
A-03	Rated_motor_voltage		
A-04	Rated_motor_current		
A-05	Rated_motor_speed		
A-06	Number_of_motor_pole		
A-07	Rated_motor_frequency		Motor_q-axis_pulse_pole_determi- nation_current
A-08	—	Number_of_PG-pulse	
A-09	PWM_carrier_frequency		
A-10	—	PG_selection	
A-11	DeadTime_compensation(T1/U_phase positive side)		
A-12	DeadTime_compensation(T1/U_phase negative side)		
A-13	DeadTime_compensation(T2/V_phase positive side)		
A-14	DeadTime_compensation(T2/V_phase negative side)		

Display	[V/f]	[IM]	[EDM]
A-15	DeadTime_compensation(T3/W_phase positive side)		
A-16	DeadTime_compensation(T3/W_phase negative side)		
A-17	Motor_primary_resistance		
A-18	—	Motor_secondary_resistance	Motor_d-axis_inductance
A-19	—	Motor_leakage_inductance	Motor_q-axis_inductance
A-20	—	Motor_mutual_inductance	Motor_magnetic_flux
A-21	—	Motor_inductance_saturation_coefficient(1)	Motor_core_loss_torque_compensation
A-22	—	Motor_inductance_saturation_coefficient(2)	Lq-change_rate_at_30%_motor_q-axis_current
A-23	—	Motor_core_loss_torque_compensation	Lq-change_rate_at_60%_motor_q-axis_current
A-24	—	Motor_loss_coefficient(1)	Lq-change_rate_at_90%_motor_q-axis_current
A-25	—	Motor_loss_coefficient(2)	Lq-change_rate_at_120%_motor_q-axis_current
A-26	—	—	Ld-change_rate_at_30%_motor_d-axis_current
A-27	—	—	Ld-change_rate_at_60%_motor_d-axis_current
A-28	—	—	Ld-change_rate_at_90%_motor_d-axis_current
A-29	—	—	Ld-change_rate_at_120%_motor_d-axis_current
A-30	—	—	Motor_d-axis_position
A-31	—	—	Pole_determination_selection
A-32	—	—	Motor_d-axis_measurement_pulse_width
A-33	—	—	Motor_d-axis_measurement_pulse_voltage_amplitude

Area b (setting area for operation mode and operation sequence)

Display	[V/f]	[IM]	[EDM]
b-00	Setting_data_rewrite_protection		
b-01	Stop_mode_selection		
b-02	Stop_frequency	Stop_speed	
b-03	DC_brake_operation_time		
b-04	—	DC_brake_gain	
b-05	JOG_stop_mode_selection		

Display	[V/f]	[IM]	[EDM]
b-06	JOG_stop_frequency	JOG_stop_speed	
b-07	Instantaneous_power_interruption_restart		
b-08	Reverse_prohibition_mode_selection		
b-09	Command_input_when_coupled		
b-10	Frequency_command_input_selection	Speed_command_input_selection	
b-11	Operation_command_input_selection		
b-12	JOG-command_input_selection		
b-13	Powering_torque_limit	Forward_powering_torque_limit	
b-14	Regenerative_torque_limit	Forward_regenerative_torque_limit	
b-15	Powering_torque_limit_usage_selection	Reverse_powering_torque_limit	
b-16	Regenerative_torque_limit_usage_selection	Reverse_regenerative_torque_limit	
b-17	Analog_frequency_command_characteristic_selection	Analog_speed_command_characteristic_selection	
b-18	Analog_frequency_command_upper_limit_frequency	Analog_speed_command_upper_limit_speed	
b-19	Analog_frequency_command_lower_limit_frequency	Analog_speed_command_lower_limit_speed	
b-20	Analog_input_ZeroLimit_voltage		
b-21	Analog_output(1)_characteristics_selection		

## Area c (setting area for parameters related to multifunction input)

Display	[V/f]	[IM]	[EDM]
c-00	Multifunction_input_place_selection		
c-01 to c-17	Multifunction_input_terminal(1) through (17)_function_selection		

## Area d (setting area for acceleration or deceleration time, frequency/speed jump functions, and MRH functions)

Display	[V/f]	[IM]	[EDM]
d-00	Acceleration/Deceleration_time_selection		
d-01	JOG_acceleration/deceleration_time_selection		
d-02	Acceleration_time(3)		
d-03	Deceleration_time(3)		
d-04	Acceleration_time(4)		
d-05	Deceleration_time(4)		
d-06	S-pattern_acceleration/deceleration_usage_selection		
d-07	S-pattern_rise_time(1)		

Display	[V/f]	[IM]	[EDM]
d-08	S-pattern_acceleration_reach_time(1)		
d-09	S-pattern_fall_time(1)		
d-10	S-pattern_deceleration_reach_time(1)		
d-11	S-pattern_rise_time(2)		
d-12	S-pattern_acceleration_reach_time(2)		
d-13	S-pattern_fall_time(2)		
d-14	S-pattern_deceleration_reach_time(2)		
d-15 to d-21	Preset_frequency(1) through (7)	Preset_speed(1) through (7)	
d-22 to d-25	Jump_frequency(1) through (4)	Jump_speed(1) through (4)	
d-26	Jump_frequency_width	Jump_speed_width	
d-27	MRH_function_usage_selection		
d-28	MRH_upper_limit_frequency	MRH_upper_limit_speed	
d-29	MRH_lower_limit_frequency	MRH_lower_limit_speed	
d-30	—	Speed_deviation_limiting_command_selection	
d-31	—	Maximum_deviation(positive)	
d-32	—	Maximum_deviation(negative)	

Area E (setting area for frequency characteristics, torque limit, torque command characteristics, and speed control)

Display	[V/f]	[IM]	[EDM]
E-00	Regeneration_stall_prevention_function_usage_selection		
E-01	Regeneration_stall_prevention_voltage		
E-02	Start_mode_selection	High-efficient_mode_usage_selection	
E-03	Forward_direction_change		
E-04	Simulation_mode		
E-05	Autoboost_mode	Torque_command_mode_selection	
E-06	Restart_delay_time	Flux_reinforcing_rate_at_start	Restart_prohibition_time
E-07	V/f_pattern_selection	Current_control_proportion_gain	
E-08	Voltage_at_turnoff_point	Current_control_integral_gain(1)	
E-09	Frequency_at_turnoff_point	Current_control_integral_gain(2)	
E-10	—	Motor_temperature_compensation	
E-11	—	Flux_command	Free_start_maximum_speed
E-12	—	Motor_cooling_fan (sensor-less_drive)	Inverter_output_maximum_voltage

## Area F (setting area for built-in dynamic brake (DB) operation, protection functions, and traceback)

Display	[V/f]	[IM]	[EDM]
F-00	Built-in_DB(DynamicBrake)_operation_level		
F-01	Forward_overfrequency_protection_setting	Forward_overspeed_protection_setting	
F-02	Reverse_overfrequency_protection_setting	Reverse_overspeed_protection_setting	
F-03	Overload_protection_setting		
F-04	Cumulative_operation_timer(1)(Main circuit capacitor life)		
F-05	Cumulative_operation_timer(2)(Cooling fan life)		
F-06	Motor_overheat_protection_operation_selection		
F-07	Protection_relay(86A)_operation_selection_upon_power_failure		
F-08	Protection_retry_count_setting		
F-09 to F-12	External_failure(1) through (4)_detection_delay_time		
F-13	Traceback_pitch		
F-14	Traceback_trigger_point		
F-15 to F-26	Traceback_CH1 through CH12_selection		
F-27	—	Overtorque_protection_function_selection	
F-28	—	Overtorque_protect_level_setting	
F-29	—	Overtorque_protection_operation_standard_torque	
F-30	—	Speed_control_error_function_usage_selection	
F-31	—	Speed_control_error_detection_speed_width(positive)	
F-32	—	Speed_control_error_detection_speed_width(negative)	

## Area G (setting area for analog input and output)

Display	[V/f]	[IM]	[EDM]
G-00	Temperature_detection_selection		
G-01	Temperature_detection_offset_adjustment		
G-02	Temperature_detection_gain_adjustment		
G-03	Analog_input(2)_characteristics_selection		
G-04	Analog_input(2)_upper_limit_frequency	Analog_input(2)_upper_limit_speed	
G-05	Analog_input(2)_lower_limit_frequency	Analog_input(2)_lower_limit_speed	
G-06	Analog_input(3)_characteristics_selection		
G-07	Analog_input(3)_upper_limit_frequency	Analog_input(3)_upper_limit_speed	

Display	[V/f]	[IM]	[EDM]
G-08	Analog_input(3)_lower_limit_fre- quency	Analog_input(3)_lower_limit_speed	
G-09	Analog_output(2)_characteristics_selection		
G-10	Analog_output(3)_characteristics_selection		
G-11	Analog_input(4)_characteristics_selection(For expanded options)		
G-12	Analog_input(5)_characteristics_selection(For expanded options)		
G-13	Analog_output(4)_characteristics_selection(For expanded options)		
G-14	Analog_output(5)_characteristics_selection(For expanded options)		
G-15	Line_speed_monitor_adjustment		
G-16	Analog_input_monitor_display_selection		
G-17	Motor_protect_temperature		

## Area H (setting area for multifunction output)

Display	[V/f]	[IM]	[EDM]
H-00 to H-05	Multifunction_output_terminal(1) through (6)_function_selection		
H-06	Frequency_detection(1)	Speed_detection(1)	
H-07	Frequency_detection(2)	Speed_detection(2)	
H-08	Frequency_detection_width	Speed_detection_width	
H-09	Torque_detection(with_polarity)		
H-10	Torque_detection(absolute_value)		
H-11	Overload_protection_pre-alarm_operation_level_setting		
H-12	Maximum_frequency_reduction_ rate	Maximum_speed_reduction_rate	

## Area i (setting area for internal PLC, droop control, and mechanical loss compensation)

Display	[V/f]	[IM]	[EDM]
i-00	PLCL_function_usage_selection		
i-01	PLCH_function_usage_selection		
i-02	Droop_control_usage_selection		
i-03	Droop_start_frequency	Droop_start_speed	
i-04	Droop_rate_changeover_frequency	Droop_rate_changeover_speed	
i-05	Droop_rate		
i-06	Droop_start_torque		
i-07	—	Operation_mode_selection	
i-08	—	Torque_command_input_place_selection	
i-09	—	Analog_input_torque_command_gain	
i-10	—	Speed_control_proportion_gain(2)	

Display	[V/f]	[IM]	[EDM]
i-11	—	Speed_control_integral_time_constant(2)	
i-12	—	System_inertia_moment(2)	
i-13	—	JOG-proportion_gain_selection	
i-14	—	ASR_cancelation_usage_selection	
i-15	—	ASR_feed-forward_usage_selection	
i-16	—	Variable_structure_proportion_gain_start_speed	
i-17	—	Variable_structure_proportion_gain_minimun_gain_percentage	
i-18	—	Initial_excitation_selection	—
i-19	—	Mechanical_loss_compensation_usage_selection	
i-20	—	Mechanical_loss_offset_amount	
i-21	—	Gradient_of_mechanical_loss	
i-22	—	Positioning_speed(0)	
i-23	—	Positioning_speed(1)	
i-24	—	Positioning_acceleration_time	
i-25	—	Positioning_deceleration_time	
i-26	—	Creep_speed	
i-27	—	Number_of_moving_pulse_within_a_creep_period	
i-28	—	Number_of_stop_pulse	
i-29	—	Positioning_emergency_stop_selection	
i-30	—	Proportion_gain_for_positioning	
i-31	—	Integral_time_constant_for_positioning	
i-32	—	System_moment_of_inertia_for_positioning	

## Area J (setting area for digital communication options)

Display	[V/f]	[IM]	[EDM]
J-00	Digital_communication_option_selection		
J-01	ASYC66-Z/CC66-Z_option_baud_rate		
J-02	OPCN66-Z_option_baud_rate		
J-03	PBUS66-Z_slave_address		
J-04	OPCN66-Z_option_input		
J-05	OPCN66-Z_option_output		
J-06	(For expanded options)		
J-07	ASYC66-Z.OPCN66-Z_transmission_selection/ CC66-Z_CC-Link_version·number_of_occupied_stations_selection EIP66-Z_IP_adress_setting (upper_2_bytes)		
J-08	ASYC66-Z/OPCN66-Z/PBUS66-Z/CC66-Z_Communication_mode_selection EIP66-Z_IP_adress_setting (lower_2_bytes)		

Display	[V/f]	[IM]	[EDM]
J-09	DNET66-Z_output_instance_number_setting		
J-10	DNET66-Z_input_instance_number_setting		
J-11	DNET66-Z_speed_scale_setting		
J-12	DNET66-Z_monitor_data_number_setting		
J-13	—	HighSpeed_response_input_selection	
J-14	Date/Time_data_selection_from_communication		
J-15	Connected_number_of_outside_DB(Dynamic_Brake)_units_VFDB2009		
J-16	EIP66-Z_Subnet_mask_setting (upper_2_bytes)		
J-17	EIP66-Z_Subnet_mask_setting (lower_2_bytes)		
J-18	EIP66-Z_Default_gate_way_setting (upper_2_bytes)		
J-19	EIP66-Z_Default_gate_way_setting (lower_2_bytes)		

## Area L (setting area for input and output gain)

Display	[V/f]	[IM]	[EDM]
L-00	Vdc_detection_gain		
L-01	Analog_input(1)_gain		
L-02	Analog_input(1)_offset		
L-03	Analog_output(1)_gain		
L-04	Analog_output(1)_offset		
L-05	Analog_input(2)_gain		
L-06	Analog_input(2)_offset		
L-07	Analog_input(3)_gain		
L-08	Analog_input(3)_offset		
L-09	Analog_output(2)_gain		
L-10	Analog_output(2)_offset		
L-11	Analog output (3) terminal		
L-12	Analog_output(3)_offset		
L-13	Analog_input(4)_gain		
L-14	Analog_input(4)_offset		
L-15	Analog_input(5)_gain		
L-16	Analog_input(5)_offset		
L-17	Analog_output(4)_gain		
L-18	Analog_output(4)_offset		
L-19	Analog_output(5)_gain		
L-20	Analog_output(5)_offset		
L-21	Inverter_operation_mode_monitor		

## Area n (monitor adjustment area)

Display	[V/f]	[IM]	[EDM]
n-00	Inverter_control_mode		
n-01	Capacity/Voltage_class		

## Area o (special adjustment area)

Display	[V/f]	[IM]	[EDM]
o-00	Special_adjustment_analog_output_address_H		
o-01	Special_adjustment_analog_output_address_L		
o-02	Special_adjustment_SET66-Z_output_address_H		
o-03	Special_adjustment_SET66-Z_output_address_L		
o-04 to o-53	—	—	—

## Area P (setting area for internal PLC and P register)

Display	[V/f]	[IM]	[EDM]
P-00 to P-99	P-register_setting		

## Area S (setting area for mode selection and analog input/output adjustment)

Display	[V/f]	[IM]	[EDM]
S-00	Special_mode_selection		
S-01	Timer_remaining_time1_clear		
S-02	Timer_remaining_time2_clear		
S-03	Vdc_adjustment		
S-04	ROM_rewrite_switch		
S-05	—		
S-06	Analog_input(1)_adjustment		
S-07	Analog_output(1)_adjustment		
S-08	Analog_input(2)_adjustment		
S-09	Analog_output(2)_adjustment		
S-10	Analog_input(3)_adjustment		
S-11	Analog_output(3)_adjustment		
S-12	Analog_input(4)_adjustment		
S-13	Analog_output(4)_adjustment		
S-14	Analog_input(5)_adjustment		
S-15	Analog_output(5)_adjustment		
S-16	Special adjustment		
S-17	Changing_parameter_upon_power_supply_from_control_power_terminal_[MR]/[MT]		

## 5.3 Detailed Explanation of Parameters

### 5.3.1 Basic Setting Area

In the basic setting area, the common-used basic setting items to operate the inverter are shown below. In this area, you can set frequency/operating speed and adjust normal acceleration or deceleration time from the console.

■ <0.FrEF>/<0.SrEF>, <1.FJoG>, <2.rJoG>

[V/f] Operating frequency setting

Display	Contents	Setting range or selecting item	Initialized data	Unit	Driving ReWrite
0.FrEF	Frequency_command	-Maximum_frequency <A-00> to +Maximum_frequency <A-00>	0.5	Hz	○
1.FJoG	Forward_JOG_fre- quency	Minimum_frequency <A-01> to 30.0	1.0	Hz	○
2.rJoG	Reverse_JOG_fre- quency	-30.0 to -Minimum_frequency <A-01>	-1.0	Hz	○

#### Frequency\_command <0.FrEF>

Set the frequency at which you operate the inverter from the console.

Parameter setting is effective in the following cases:

- When you select "1" (console) in the Command\_input\_when\_coupled <b-09> and select "0" (interlocked) in the Frequency\_command\_input\_selection <b-10>
- When you select "2" (console) in the Frequency\_command\_input\_selection <b-10>

#### Forward\_JOG\_frequency <1.FJoG>

#### Reverse\_JOG\_frequency <2.rJoG>

Set the forward or reverse jog frequency.

[IM] [EDM] Operating speed setting

Display	Contents	Setting range or selecting item	Initialized data	Unit	Driving ReWrite
0.SrEF	Speed_command	-Maximum_speed <A-00> to +Maximum_speed <A-00>	0	r/min	○
1.FJoG	Forward_JOG_speed	Minimum_speed <A-01> to 300	24	r/min	○
2.rJoG	Reverse_JOG_speed	-300 to -Minimum_speed <A-01>	-24	r/min	○

#### Speed\_command <0.SrEF>

Set the speed at which you operate the inverter from the console.

Parameter setting is effective in the following cases:

- When you select "1" (console) in the Command\_input\_when\_coupled <b-09> and select "0" (interlocked) in the Speed\_command\_input\_selection <b-10>
- When you select "2" (console) in the Speed\_command\_input\_selection <b-10>

**Forward\_JOG\_speed <1.FJoG>****Reverse\_JOG\_speed <2.rJoG>**

Set the forward or reverse jog speed.

■ <3.Acc1>, <4.dEc1>, <5.Acc2>, <6.dEc2>

Acceleration or deceleration time setting

Display	Contents	Setting range or selecting item	Initialized data	Unit	Driving ReWrite
3.Acc1	Acceleration_time(1)	0.0 to 3600.0	30.0	sec	○
4.dEc1	Deceleration_time(1)				
5.Acc2	Acceleration_time(2)	0.0 to 3600.0	0.3	sec	○
6.dEc2	Deceleration_time(2)				

**Acceleration\_time(1) and Deceleration\_time(1) <3.Acc1><4.dEc1>**

**Acceleration\_time(2) and Deceleration\_time(2) <5.Acc2><6.dEc2>**

Set the acceleration time from 0 to the Maximum\_frequency/Maximum\_speed <A-00> and the deceleration time from the Maximum\_frequency/Maximum\_speed <A-00> to 0.

The inverter provides four types of acceleration time and deceleration time, and they can be switched by multifunction input with settings or from outside.

In the default setting, the Acceleration\_time(1) and Deceleration\_time(1) <3.Acc1><4.dEc1> are for normal operation, and the Acceleration\_time(2) and Deceleration\_time(2) <5.Acc2><6.dEc2> are for jog operation.

**Possible to set four types of acceleration and deceleration time**

For the Acceleration\_time(3)/Deceleration\_time(3) and Acceleration\_time(4)/Deceleration\_time(4) which are not described in this section, you can set them in the parameters <d-02> through <d-05> of the area d.

■ [V/f] <7.tbSt>, <8.dcbR>, <9.Stb>

[V/f] Torque boost amount setting

Display	Contents	Setting range or selecting item	Initialized data	Unit	Driving ReWrite
7.tbSt	Torque_boost_amount	0.0 to 20.0	0.0	%	○

**Torque\_boost\_amount <7.tbSt>**

Set the manual boost voltage as a ratio to the Rated\_motor\_voltage <A-03>.

When torque is not sufficient at start, you can make starting torque higher by setting a larger value to this parameter to increase current at start.

This function not available when the auto boost is selected.

Also refer to the boost\_mode\_selection <E-05> and the V/f\_pattern\_selection <E-07>.

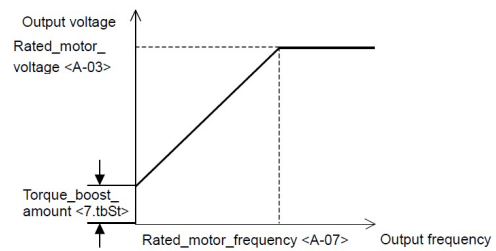

[V/f] DC brake amount setting

Display	Contents	Setting range or selecting item	Initialized data	Unit	Driving ReWrite
8.dabr	DC_brake_voltage	0.0 to 20.0	0.0	%	○

**DC\_brake\_voltage <8.dabr>**

Set the DC brake voltage as a ratio to the Rated\_motor\_voltage <A-03>. You can increase DC brake amount by setting a larger value to this parameter.

However, excessive current flow may cause the overload protection. Also refer to the DC\_brake\_operation\_time <b-03>.

[V/f] Stabilizer (stabilization adjustment) setting

Display	Contents	Setting range or selecting item	Initialized data	Unit	Driving ReWrite
9.Stb	Stabilizer_amount	0.0 to 100.0	0.0	%	○

**Stabilizer\_amount <9.Stb>**

If the motor rotates unsteadily, you can stabilize it by adjusting this parameter.

Operate the motor at frequency which it rotates unsteadily, and gradually increase the stabilizer amount until it rotates steadily. Note that excessive amount will cause rotation of the motor to be unstable.

■ [IM] [EDM] <7.ASrP>, <8.ASri>, <9.ASrJ>

[IM] [EDM] Speed control gain setting

Display	Contents	Setting range or selecting item	Initialized data	Unit	Driving ReWrite
7.ASrP	Speed_control_proportion_gain(1)	1 to 50	15	—	○
8.ASri	Speed_control_integral_time_constant(1)	20 to 10000	40	msec	○
9.ASrJ	System_inertia_moment(1)	0 to 65535	10	gm <sup>2</sup>	○

In the vector control of the inverter, you can control speed with the MFC control which combines the feed forward with the cancellation using the disturbance torque observer.

**Speed\_control\_proportion\_gain(1) <7.ASrP>**

Set the speed control proportion gain.

**Speed\_control\_integral\_time\_constant(1) <8.ASri>**

Set the speed control integral gain equivalent with a filter time constant.

**System\_inertia\_moment(1) <9.ASrJ>**

Set the inertia moment used for speed control cancellation and feed forward in gm<sup>2</sup>. Typically, input 20 to 100 % of a value where inertia moment of the motor itself is added to a load inertia moment value converted to the motor shaft.

In case of the gear rattle caused by large gear backlash or the belt vibration connected motor and load, take the following measures:

- Set a smaller value.
- Change the settings of the ASR\_cancellation\_usage\_selection <i-14> and the ASR\_feed-forward\_usage\_selection <i-15>. Not use the cancellation and feed forward.

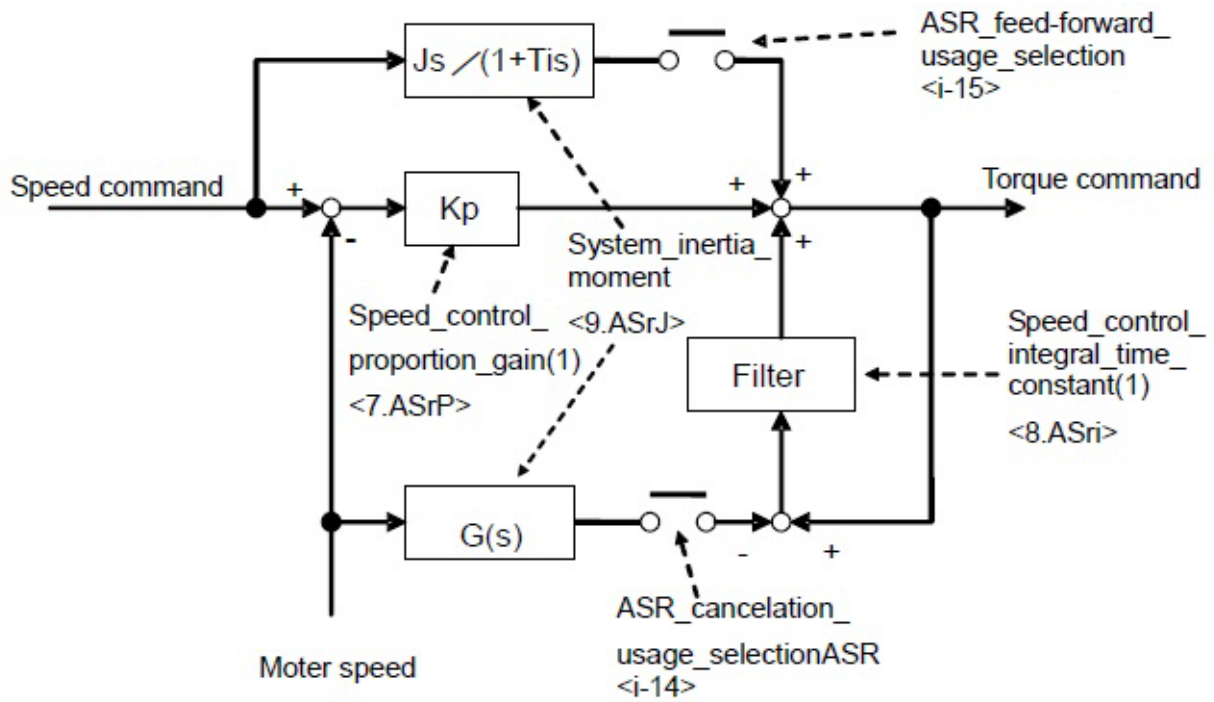

Speed control block

### 5.3.2 Area A (Setting Area for Maximum Frequency/Maximum Speed, Rated Motor, and Other Parameters)

In the area A, set the motor parameters required for control by the inverter.

Before operating the inverter, be sure to set each parameter for your motor and system.

#### Autotuning of area A parameters

〈A-11〉 and subsequent parameters are automatically set by Autotuning.

Before operating the inverter, perform Autotuning with your motor. For how to perform Autotuning, refer to [4.3 Autotuning of Parameters (Automatic Setting)].

#### ■ 〈A-00〉, 〈A-01〉

[V/f] Motor maximum and minimum frequency setting

Display	Contents	Setting range or selecting item	Initialized data	Unit	Driving ReWrite
A-00	Maximum_frequency	15.0 to 400.0	60.0	Hz	×
A-01	Minimum_frequency	0.0 to 10.0	0.5	Hz	○

#### Maximum\_frequency 〈A-00〉

Set the maximum frequency (absolute value) at which the motor operates. The inverter controls frequency, considering this value as 100 % (standard). Set a value more than or equal to the rated frequency for your motor.

#### Minimum\_frequency 〈A-01〉

Set the minimum frequency (absolute value) at which the motor operates. When the frequency command is less than or equal to this setting value, the inverter limits frequency to this setting value.

When "Minimum frequency start" is selected in the Start\_mode\_selection 〈E-02〉, the output frequency starts at the frequency specified in 〈A-01〉.

[IM] [EDM] Motor maximum and minimum speed setting

Display	Contents	Setting range or selecting item	Initialized data	Unit	Driving ReWrite
A-00	Maximum_speed	[IM] 300 to 14700	1800	r/min	×
		[EDM] 300 to 14700			
A-01	Minimum_speed	[IM] 0 or 12 (Depending on the setting of the PG_selection 〈A-10〉) to Maximum_speed 〈A-00〉	12	r/min	○
		[EDM] 0 to Maximum_speed 〈A-00〉	0		

**Maximum\_speed <A-00>**

Set the maximum speed (absolute value) at which the motor operates. The inverter controls speed, considering this value as 100 % (standard).

The above table lists the maximum value which can be set in the inverter. However, in reality it should be set to a value to meet the following requirements according to the rating of your motor. When using the speed less than or equal to the rated motor speed, set a value of the rated motor speed.

- [IM]

- (1) One to four times the rated speed of your motor.
- (2) 400 Hz or less when speed is converted to frequency. For instance, when the number of motor poles is four and six, it should be 12000 r/min or less and 8000 r/min or less, respectively.

- [EDM]

- (1) One to 1.33 times the rated speed of your motor.
- (2) 400 Hz or less when speed is converted to frequency. For instance, when the number of motor poles is six, it should be 8000 r/min or less.

**Minimum\_speed <A-01>**

Set the minimum speed (absolute value) at which the motor operates. For speed control, even when you input a speed command below this speed as an absolute value, it will be limited to this setting value.

When the motor operates in the torque control mode with the Operation\_mode\_selection <i-07>, the setting of <A-01> is not available.

<b>Minimum value of minimum speed in [IM]</b>
The minimum value (unit: r/min) in the setting range of the Minimum_speed <A-01> depends on the PG_selection <A-10>. When <A-10> is "0," the minimum value is "12." When <A-10> is "1," it is "0."

■ [V/f] [IM] <A-02> through <A-07>, [EDM] <A-02> through <A-06>

Set the values of the motor nameplate.

[V/f] Motor nameplate value setting

Display	Contents	Setting range or selecting item	Initialized data	Unit	Driving ReWrite
A-02	Rated_motor_capacity	0 to Rated capacity of the inverter* <sup>1</sup>	Inverter rating* <sup>2</sup>	kW	×
A-03	Rated_motor_voltage	[200 V class] 70 to 230	200	V	×
		[400 V class] 140 to 460	400		
A-04	Rated_motor_current	20 to 150 % of the rated inverter current	Inverter rating* <sup>2</sup>	A	×
A-05	Rated_motor_speed	400 to 24000	1760	r/min	×
A-06	Number_of_motor_pole	2 to 12	4	Pole	×
A-07	Rated_motor_fre- quency	15.0 to Maximum_frequency <A-00>	60.0	Hz	×

[IM] Motor nameplate value setting

Display	Contents	Setting range or selecting item	Initialized data	Unit	Driving ReWrite
A-02	Rated_motor_capacity	Value depending on the inverter to Rated capacity of the inverter* <sup>1</sup>	0.00* <sup>2</sup>	kW	×
A-03	Rated_motor_voltage	[200 V class] 70 to 230	0	V	×
		[400 V class] 140 to 460			
A-04	Rated_motor_current	20 to 150 % of the rated inverter current	0.00* <sup>2</sup>	A	×
A-05	Rated_motor_speed	20 to 100 % of Maximum_speed <A-00>	0	r/min	×
A-06	Number_of_motor_pole	2 to 12	4	Pole	×
A-07	Rated_motor_fre- quency	(Rated speed x Number of poles/120) to (Rated speed x Number of poles/120 + 7.0)	0.0	Hz	×

[EDM] Motor nameplate value setting

Display	Contents	Setting range or selecting item	Initialized data	Unit	Driving ReWrite
A-02	Rated_motor_capacity	Value depending on the inverter to 150 % of rated capacity of the inverter* <sup>1</sup>	0.00* <sup>2</sup>	kW	×
A-03	Rated_motor_voltage	[200 V class] 70 to 230	0	V	×
		[400 V class] 140 to 460			
A-04	Rated_motor_current	20 to 150 % of the rated inverter current	0.00* <sup>2</sup>	A	×
A-05	Rated_motor_speed	20 to 100 % of Maximum_speed <A-00>	0	r/min	×
A-06	Number_of_motor_pole	2 to 64	6	Pole	×

\* 1: The maximum value in the setting range becomes larger proportional to the rated motor voltage when it is larger than 190 V [200 V class] or 380 V [400 V class].

[200 V class] Maximum value of <A-02> = (Rated capacity of the inverter) × <A-03>/190V

[400 V class] Maximum value of <A-02> = (Rated capacity of the inverter) × <A-03>/380V

[IM] [EDM] For the minimum value in the setting range of <A-02>, refer to {5.1.2 Induction Motor Vector Control} (it is common to both [IM] and [EDM]).

- \* 2: For Initialized data of <A-02> and <A-04>, the position of its decimal point depends on the inverter capacity.

**Rated\_motor\_capacity <A-02>**

**Rated\_motor\_voltage <A-03>**

**Rated\_motor\_current <A-04>**

**Rated\_motor\_speed <A-05>**

**Number\_of\_motor\_pole <A-06>**

**Rated\_motor\_frequency <A-07> for [V/f] and [IM] only**

In <A-02> through <A-07> (through <A-06> for [EDM]), set the each rated value described in the motor nameplate or the data sheet.

Before performing Autotuning, be sure to set these values because they are used during operation and Autotuning.

Set each value described in the motor nameplate or the data sheet as shown in the figure to the right.

For the motor that has two types of rated voltage and rated current, set a larger value within the speed range in the Rated\_motor\_voltage <A-03> and the Rated\_motor\_current <A-04>.

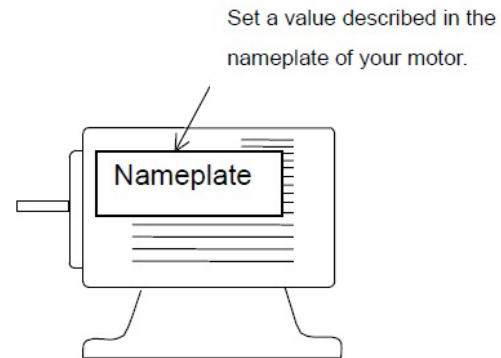

- [V/f]  
V/f characteristics mean the condition where the output voltage becomes the Rated\_motor\_voltage <A-03> when the output frequency is equal to the Rated\_motor\_frequency <A-07>. When the output frequency is more than or equal to the Rated\_motor\_frequency <A-07>, the output voltage becomes constant in the Rated\_motor\_voltage <A-03>.
- [IM] [EDM]  
When using the motor until the constant output (power constant) range, set the base speed in the Rated\_motor\_speed <A-05>. When the speed is slower than or equal to the Rated\_motor\_speed <A-05>, the torque constant control area is used. When the speed is faster than or equal to the Rated\_motor\_speed <A-05>, the power constant control area is used.

#### ■ [EDM] <A-07>

[EDM] Motor q-axis pulse pole determination current

Display	Contents	Setting range or selecting item	Initialized data	Unit	Driving ReWrite
A-07	Motor_q-axis_pulse_pole_determination_current	0 to 200 (ratio to the rated motor current)	50	%	×

#### **Motor\_q-axis\_pulse\_pole\_determination\_current <A-07>**

When the Pole\_determination\_selection <A-31> is set to "Motor q-axis pulse pole determination," apply the current specified in this parameter to determine the pole direction at start using [EDM].

When the Pole\_determination\_selection <A-31> is set to "Motor d-axis pulse pole determination," this setting is

not used.

#### ■ [IM] [EDM] <A-08>

[IM] [EDM] Number of PG-pulse setting

Display	Contents	Setting range or selecting item	Initialized data	Unit	Driving ReWrite
A-08	Number_of_PG-pulse	60 to 32767	600	P/R	×

#### Number\_of\_PG-pulse <A-08>

When using PG as a speed sensor in [IM] or as a position and speed sensor in [EDM], set the pulse number of PG directly connected to your motor shaft in the Number\_of\_PG-pulse <A-08>.

In the speed vector control without sensor or the position and speed vector control without sensor, the setting of <A-08> is ignored.

- [EDM]

When "3" (RL mode) is selected in the PG\_selection <A-10>, the maximum value in the setting range is 256 x (Number of resolver poles).

When "4" (RH mode) is selected in the PG\_selection <A-10>, the maximum value in the setting range is 256 x (Number of resolver poles) x 4.

#### ■ <A-09>

PWM carrier frequency setting

Display	Contents	Setting range or selecting item	Initialized data	Unit	Driving ReWrite
A-09	PWM_carrier_frequency	[V/f] 1.0 to 6.0	2.0	kHz	×
		[IM] [EDM] 1.0 to 6.0	6.0		

#### PWM\_carrier\_frequency <A-09>

This indicates the modulating carrier frequency of the inverter voltage output PWM.

- [IM] [EDM]

Since the torque control cycle needs to be synchronized with the PWM carrier frequency, changing the PWM carrier frequency will change control characteristics.

Especially, when the PWM carrier frequency is set to less than 2 kHz, the torque control cycle is delayed, which may cause characteristics to be worse. Typically, use it at a frequency of 6.0 kHz.

#### PWM carrier frequency when ED motor is used

Please set the inverter's PWM carrier frequency to 6kHz when using ED motor.

If the value of the inverter's PWM carrier frequency is changed from 6kHz, please contact us.

### ■ [IM] [EDM] <A-10>

#### [IM] [EDM] PG selection

Display	Contents	Setting range or selecting item	Initialized data	Unit	Driving ReWrite
A-10	PG_selection	[IM] 0: S mode drive without sensor 1: V mode with PG (A,B phase input) drive	0	—	×
		[EDM] 0: S mode drive without sensor 1: V mode with PG (A,B,Z phase input) drive 2: P mode with PG (A,B,U,V,W phase input) drive 3: RL mode with resolver drive (Resolution 10 bit) 4: RH mode with resolver drive (Resolution 12 bit)	0	—	×

### PG\_selection <A-10>

Select whether or not PG is used.

In the default setting, "0" (S mode) drive without sensor, or "Without PG," is selected.

To perform drive with PG, you need the PG input board <PG66-Z> or a separate optional board. When using <PG66-Z>, turn on the switch [SW2] on the <PG66-Z> with a pair of tweezers or a tool whose tip is very short in length (about 0.8 mm). For an optional board, refer to the optional "Instruction Manual."

- [EDM]

When selecting drive with PG, typically select "2" (P mode) drive with PG (ABUVW phase input).

"1" (V mode) drive with PG (ABZ phase input) is a special mode.

To perform drive with the resolver, you need an optional board.

### ■ <A-11> through <A-29>

These parameters are set by Autotuning. They include settings of deadtime compensation of IGBT inside the inverter, motor primary resistance, and others.

#### Autotuning of area A parameters

<A-11> and subsequent parameters are automatically set by Autotuning. You do not have to set them manually.

Before operating the inverter, perform Autotuning with your motor. For how to perform Autotuning, refer to {4.3 Autotuning of Parameters (Automatic Setting)}.

## [V/f] Autotuning setting parameters

Display	Contents	Setting range or selecting item	Initialized data	Unit	Driving ReWrite
A-11	DeadTime_compensation(T1/U_phase positive side)	0.00 to 9.99	(Refer to another table*)	$\mu$ sec	×
A-12	DeadTime_compensation(T1/U_phase negative side)				
A-13	DeadTime_compensation(T2/V_phase positive side)				
A-14	DeadTime_compensation(T2/V_phase negative side)				
A-15	DeadTime_compensation(T3/W_phase positive side)				
A-16	DeadTime_compensation(T3/W_phase negative side)				
A-17	Motor_primary_resistance	Depending on the rated inverter (refer to another table *)	(Refer to another table*)	m $\Omega$	×

\* For the initialized data of the <A-11> through <A-17> depending on the inverter model and the setting range of <A-17>, refer to {5.1.1 V/f Control}.

**DeadTime\_compensation <A-11> through <A-16>**

In <A-11> through <A-16>, set the deadtime compensation of IGBT for each phase inside the inverter to accurately calculate output voltage used for control operation.

Deadtime compensation settings for a total of six elements (positive side and negative side for each T1/U, T2/V, and T3/W phase) are provided.

**Motor\_primary\_resistance <A-17>**

In <A-17>, set (motor primary resistance) + (wiring resistance from inverter to motor).

In the factory default setting, a typical value is provided depending on the inverter capacity. Although you can operate the inverter with the initialized data, you should perform Autotuning for more accurate operation.

[IM] [EDM] Autotuning setting parameters (deadtime compensation of IGBT inside the inverter)

Display	Contents	Setting range or selecting item	Initialized data	Unit	Driving ReWrite
A-11	DeadTime_compensation(T1/U_phase positive side)	0.00 to 9.99	0.00	$\mu$ sec	×
A-12	DeadTime_compensation(T1/U_phase negative side)				
A-13	DeadTime_compensation(T2/V_phase positive side)				
A-14	DeadTime_compensation(T2/V_phase negative side)				
A-15	DeadTime_compensation(T3/W_phase positive side)				
A-16	DeadTime_compensation(T3/W_phase negative side)				

**DeadTime\_compensation <A-11> through <A-16>**

In <A-11> through <A-16>, set the deadtime compensation of IGBT for each phase inside the inverter to accurately calculate output voltage used for control operation.

Deadtime compensation settings for a total of six elements (positive side and negative side for each T1/U, T2/V, and T3/W phase) are provided.

## [IM] Autotuning setting parameters (motor electric constant)

Display	Contents	Setting range or selecting item	Initialized data	Unit	Driving ReWrite
A-17	Motor_primary_resistance	(The setting range depends on the inverter capacity.*2)	0.0*1	mΩ	×
A-18	Motor_secondary_resistance				
A-19	Motor_leakage_inductance	(The setting range depends on the inverter capacity.*2)	0.0*1	mH	×
A-20	Motor_mutual_inductance				
A-21	Motor_inductance_saturation_coefficient (1)	0.0 to 50.0	0.0	%	×
A-22	Motor_inductance_saturation_coefficient (2)				
A-23	Motor_core_loss_torque_compensation	0.0 to 20.0	0.0	%	×
A-24	Motor_loss_coefficient (1)	0.0 to 200.0	0.0	%	×
A-25	Motor_loss_coefficient (2)				

\* 1: The decimal point position of the initialized data depends on the inverter capacity.

\* 2: For the setting range of <A-17> through <A-20>, refer to {5.1.2 Induction Motor Vector Control}.

**Motor\_primary\_resistance <A-17>**

Set (Motor primary resistance) + (Wiring resistance from inverter to motor).

You can set the optimal value by performing Autotuning.

<A-17> is set by the Full Mode Autotuning or the Direct Current Mode Autotuning.

Since the vector mode requires a correct value for <A-11> to <A-17>, you should always perform one of Autotuning.

If the wiring length is significantly changed after Autotuning, perform Autotuning again.

**Motor\_secondary\_resistance <A-18>**

Set the value where the motor secondary resistance (= rotor resistance) is converted on the primary side.

When you cannot perform Autotuning and the value from the motor data sheet is set manually, set a value converted to 25 °C.

**Motor\_leakage\_inductance <A-19>**

Set the motor leakage inductance.

When you cannot perform Autotuning and a value from the motor data sheet is set manually, set the average of the primary side leakage inductance and the secondary side leakage inductance (converted value on the primary side).

**Motor\_mutual\_inductance <A-20>**

Set the motor mutual inductance.

Inductance is saturated by magnetic flux. Here, set the inductance value at rated magnetic flux.

**Motor\_inductance\_saturation\_coefficient(1) <A-21>, Motor\_inductance\_saturation\_coefficient(2) <A-**

## 22&gt;

These indicate a compensation coefficient which corrects mutual inductance saturation.

You set the rate of increase in % to the Motor\_mutual\_inductance <A-20> where the magnetic flux reaches 90 % or 70 % of the rated magnetic flux.

**Motor\_core\_loss\_torque\_compensation <A-23>**

Set the core loss torque compensation in the motor.

**Motor\_loss\_coefficient(1) <A-24>, Motor\_loss\_coefficient(2) <A-25>**

These are a coefficient which indicates electrical or mechanical loss measured by Autotuning.

Since these parameters are not used for controlling, you do not need to set them manually.

[EDM] Autotuning setting parameters (motor electric constant)

Display	Contents	Setting range or selecting item	Initialized data	Unit	Driving ReWrite
A-17	Motor_primary_resistance	(The setting range depends on the inverter capacity.*2)	0.0*1	mΩ	×
A-18	Motor_d-axis_inductance	(The setting range depends on the inverter capacity.*2)	0.0*1	mH	×
A-19	Motor_q-axis_inductance				
A-20	Motor_magnetic_flux	0.000 to 9.999	0.000	Wb	×
A-21	Motor_core_loss_torque_compensation	0.0 to 20.0	0.0	%	×
A-22	Lq-change_rate_at_30%_motor_q-axis_current	-100.0 to 100.0	0.0	%	×
A-23	Lq-change_rate_at_60%_motor_q-axis_current				
A-24	Lq-change_rate_at_90%_motor_q-axis_current				
A-25	Lq-change_rate_at_120%_motor_q-axis_current				
A-26	Ld-change_rate_at_30%_motor_d-axis_current	-100.0 to 100.0	0.0	%	×
A-27	Ld-change_rate_at_60%_motor_d-axis_current				
A-28	Ld-change_rate_at_90%_motor_d-axis_current				
A-29	Ld-change_rate_at_120%_motor_d-axis_current				

- \* 1: The decimal point position of the initialized data depends on the inverter capacity.
- \* 2: For the setting range of <A-17> through <A-19>, refer to {5.1.3 ED Motor Vector Control}.

### Motor\_primary\_resistance <A-17>

Set (Motor primary resistance) + (Wiring resistance from inverter to motor).

You can set the optimal value by performing Autotuning.

<A-17> is set by the Full Mode Autotuning or the Direct Current Mode Autotuning.

Since the vector mode requires a correct value for <A-11> to <A-17>, you should always perform one of Autotuning.

If the wiring length is significantly changed after Autotuning, perform it again.

### Motor\_d-axis\_inductance <A-18>, Motor\_q-axis\_inductance <A-19>

Set the motor d-axis inductance and motor q-axis inductance.

These parameters are set by the Full Mode Autotuning.

### Motor\_magnetic\_flux <A-20>

Set the interlinkage magnetic flux to the primary winding of the permanent magnet embedded in the rotor of the ED motor.

This parameter is set by the Full Mode Autotuning.

### Motor\_core\_loss\_torque\_compensation <A-21>

Set the core loss torque compensation in the ED motor.

This parameter is set by the Full Mode Autotuning.

### Lq-change\_rate <A-22> through <A-25>, Ld-change\_rate <A-26> through <A-29>

In <A-22> through <A-29>, set the change rate (correction factor) of motor d-axis or q-axis inductance at 30 %, 60 %, 90 %, or 120 % current.

Calculate the actual inductance from the Motor\_d-axis\_inductance <A-18>, the Motor\_q-axis\_inductance <A-19>, and these setting values, and then perform control operation.

This parameter is set by the Full Mode Autotuning.

### ■ [EDM] <A-30>

[EDM] Motor d-axis position setting

Display	Contents	Setting range or selecting item	Initialized data	Unit	Driving ReWrite
A-30	Motor_d-axis_position	0 to 32767	-1	—	×

### Motor\_d-axis\_position <A-30>

For PG, set the angle from the reference position angle to the position angle of the magnetic pole of the magnet embedded in the rotor as PG-pulse count number.

For the resolver, set the position angle of the magnetic pole of the magnet as an absolute position.

This parameter is set by the Full Mode Autotuning when the PG\_selection <A-10> is set to "2" (P mode) or "1" (V mode).

- Even when you perform Autotuning with the PG\_selection <A-10> set to "0" (S mode), this parameter is not set.
- A value of "-1" in the Motor\_d-axis\_position <A-30> indicates that the initialized data remains unset.
- When switching the PG\_selection <A-10> to "2" (P mode) or "1" (V mode) and starting the inverter without performing Autotuning, the protection will operate to stop the inverter.

Even if the model of the motor is the same, its value depends on the setting angle of PG or the resolver. Be sure to set a value after performing Autotuning for each motor.

Also, when changing the wiring of the inverter output terminals [T1/U, T2/V, T3/W] and reversing the motor, you need to perform Autotuning again.

## ■ [EDM] <A-31> through <A-33>

### [EDM] Pole determination setting

Display	Contents	Setting range or selecting item	Initialized data	Unit	Driving ReWrite
A-31	Pole_determination_selection	0: Motor q-axis pulse pole determination (1) 1: Motor q-axis pulse pole determination (2) 2: Motor d-axis pulse pole determination	0	—	×
A-32	Motor_d-axis_measurement_pulse_width	-12.7 to 12.7	0.0	msec	×
A-33	Motor_d-axis_measurement_pulse_voltage_amplitude	0: 30 % 1: 50 % 2: 75 % 3: 100 % 4: 7 % 5: 9.5 % 6: 12 % 7: 20 %	0	—	×

The following determination settings are performed by Autotuning:

- Pole direction determination by Autotuning in the Motor D-axis Measurement Mode
- Pole determination when the PG\_selection <A-10> is set to "0" (S mode) drive without sensor (without PG)
- Pole determination at start without sensor during the initial operation after power-on when the PG\_selection <A-10> is set to "1" (V mode)

### **Pole\_determination\_selection <A-31>**

[EDM] of the inverter provides two types of pole determination selections: "Motor d-axis pulse pole determination" and "Motor q-axis pulse pole determination."

Performing the Full Mode Autotuning will automatically set the pole determination suited for your motor characteristics to be applied to <A-31>.

Differences between the Motor q-axis pulse pole determination (1) and the Motor q-axis pulse pole determination (2) are conditions determined when the Full Mode Autotuning is performed. The motor q-axis pulse pole determination is used for operation in both ways.

### **Motor\_d-axis\_measurement\_pulse\_width <A-32>**

Set the pulse time width in the motor d-axis pulse pole determination. A negative value indicates that a determined pole has a negative characteristic.

This parameter is set by the Full Mode Autotuning.

### **Motor\_d-axis\_measurement\_voltage\_amplitude <A-33>**

Set the pulse voltage amplitude in the motor d-axis pulse pole determination.

This parameter is set by the Full Mode Autotuning.

### **<Motor d-axis pulse pole determination setting>**

When the Pole\_determination\_selection <A-31> is set to "Motor d-axis pole determination" by Autotuning:

- The settings of the Motor\_d-axis\_measurement\_pulse\_width <A-32> and the Motor\_d-axis\_measurement\_pulse\_voltage\_amplitude <A-33> will be enabled.

**<Motor q-axis pulse pole determination setting>**

When the Pole\_determination\_selection <A-31> is set to "Motor q-axis pole determination (1)" or "Motor q-axis pole determination (2)" by Autotuning and also the PG\_selection <A-10> is set to "0" (S mode) start without sensor or "1" (V mode) initial start without sensor after power-on:

- The setting of the Motor\_q-axis\_pulse\_pole\_determination\_current <A-07> will be enabled.
- This setting is not used by Autotuning in the Motor D-axis Measurement Mode.
- In the Motor\_q-axis\_pulse\_pole\_determination\_current <A-07>, set the command value of the motor q-axis pulse current as a ratio to the rated motor current.

Typically, it should be 50 % of the initialized data. If "Sensor-less start error (SLSE)" protection operates at start depending on load conditions, you should adjust this setting to a large degree.

However, note that increasing a value too much will cause a large shock at start.



### **CAUTION** About start in the ED motor vector control

- You can switch the setting of the Pole\_determination\_selection <A-31> manually.

However, when switching it manually, the inverter might determine the pole incorrectly, which can output torque in a direction opposite to the commanding direction.

In principle, do not change a value set by Autotuning.

- In the motor q-axis pulse pole determination, the rotor may rotate a few degrees at start. Note that it cannot be used in the system where this reverse behavior may cause any problem.

### 5.3.3 Area b (Setting Area for Operation Mode and Operation Sequence)

In area b, set the parameters related to the operation mode or stop mode of the inverter and operation sequence.

#### ■ <b-00>

Setting data rewrite protection setting

Display	Contents	Setting range or selecting item	Initialized data	Unit	Driving ReWrite
b-00	Setting_data_rewrite_protection	OFF: Without protection ON: With protection	OFF	—	×

#### Setting\_data\_rewrite\_protection <b-00>

When <b-00> is set to "ON," you cannot change data from the console or in other ways.

When you want to change the setting value of the parameter, select this as "OFF."

When you try to rewrite data with <b-00> set to "ON," "PrnCt" appears in the seven-segment display on the console.

#### ■ <b-01> through <b-06>

Stop mode setting

Display	Contents	Setting range or selecting item	Initialized data	Unit	Driving ReWrite
b-01	Stop_mode_selection	0: Free stop 1: Deceleration stop 2: Deceleration stop with DC brake	1	—	○
b-02	[V/f] Stop_frequency	0.0 to 30.0	1.0	Hz	○
	[IM] [EDM] Stop_speed	0 to 300	30	r/min	
b-03	DC_brake_operation_time	0.0 to 10.0	0.0	sec	○
b-04	[V/f] —	—	—	—	—
	[IM] [EDM] DC_brake_gain	20.0 to 500.0 (Rated excitation current = 100 %)	100.0	%	○
b-05	JOG_stop_mode_selection	0: Free stop 1: Deceleration stop 2: Deceleration stop with DC brake	0	—	○
b-06	[V/f] JOG_stop_frequency	0.0 to 10.0	1.0	Hz	○
	[IM] [EDM] JOG_stop_speed	0 to 300	30	r/min	

In the Stop\_mode\_selection <b-01> and the JOG\_stop\_mode\_selection <b-05>, select a behavior when turning off an operation or jog command.

For [IM] and [EDM], when the Operation\_mode\_selection <i-07> is not "0" (speed control mode), free stop

always occurs regardless of the settings of <b-01> and <b-05>. In the JOG\_stop\_speed <b-06>, set the speed at JOG stop.

Differences among these stop modes are as follows:

### Free stop

Turning off an operation or JOG command will cause the inverter to stop voltage output.

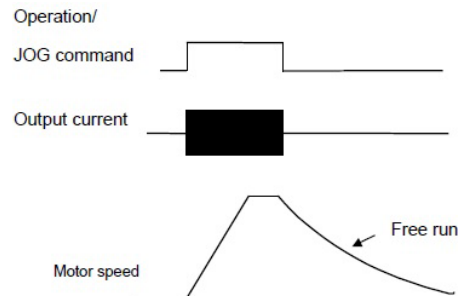

### Deceleration stop

The inverter gradually decelerates according to the deceleration time until it reaches the settings of the Stop\_frequency/Stop\_speed <b-02> and the JOG\_stop\_frequency/JOG\_stop\_speed <b-06>, and then it stops voltage output.

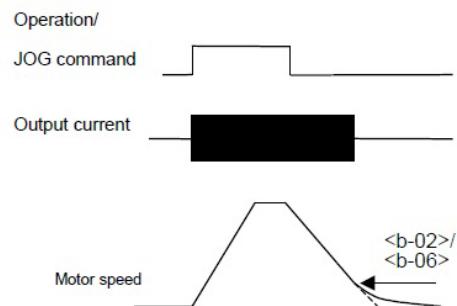

### Deceleration stop with DC brake

The inverter gradually decelerates according to the deceleration time until it reaches the speed specified in the Stop\_frequency/Stop\_speed <b-02> and the JOG\_stop\_frequency/JOG\_stop\_speed <b-06>, and then it puts on the DC brake for the amount of time specified in the DC\_brake\_operation\_time <b-03>.

• [V/f]

You can adjust current at DC brake with the DC\_brake\_voltage <8.dcbv> in the basic setting area.

• [IM] [EDM]

You can set current at DC brake with the DC\_brake\_gain <b-04>.

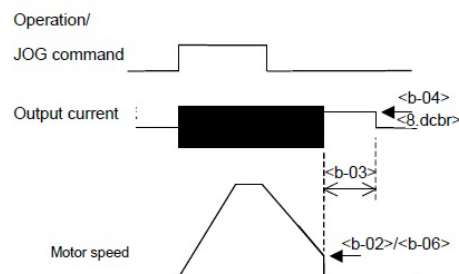

## CAUTION About free run in the ED motor vector control

- Since the ED motor has the permanent magnet embedded in the rotor, it generates voltage proportional to speed even in the free run condition.
- In the area where generated voltage is higher than direct current voltage of the inverter (for example, running in the constant output (power constant) area), the inverter continues to control and to generate voltage until it reaches the speed where generated voltage is lower than direct current voltage even when free stop is selected.
- When you use the constant output (power constant) area and want to immediately stop output voltage with the operation turned off, put the main circuit contactor (52M) between the motor and the inverter to operate it with a relay contact [52MA].

## ■ &lt;b-07&gt;

Instantaneous power interruption restart behavior setting

Display	Contents	Setting range or selecting item	Initialized data	Unit	Driving ReWrite
b-07	Instantaneous_power_ interruption_restart	OFF: Not restart ON: Restart	OFF	—	×

**Instantaneous\_power\_interruption\_restart <b-07>**

Select whether or not restarting the inverter after restoring power when instantaneous power interruption occurs and the operation is temporarily stopped.

Instantaneous power interruption means that direct current voltage becomes the specified value or less and then returns to the specified value or more without control power failure.

- "OFF": The inverter does not restart even after the power is restored.  
It remains to be stopped.  
To restart it, you need to turn off the operation or JOG command and turn it on.
- "ON": The inverter automatically restarts after the power is restored.  
However, when it operates from the contact signal or the digital communication option command, the operation command to the inverter should be kept "ON."  
After the inverter stops, when you cannot restart it with the operation command kept "ON," the startup stall protection (StrF) will operate.

**WARNING** About instantaneous power interruption restart

- When the Instantaneous\_power\_interruption\_restart <b-07> is set to "ON," the motor automatically restarts after detecting instantaneous power interruption and restoring power. Therefore, do not come close to the motor while instantaneous power interruption is being detected.

Otherwise, you may be injured.

## ■ &lt;b-08&gt;

## Reverse prohibition mode setting

Display	Contents	Setting range or selecting item	Initialized data	Unit	Driving ReWrite
b-08	Reverse_prohibition_mode_selection	0: Normal 1: Reverse prohibition against command 2: Reverse prohibition	0	—	×

**Reverse\_prohibition\_mode\_selection <b-08>**

Set the reverse prohibition.

- Normal <b-08>: "0"  
It indicates the normal operation and does not have limitations of forward and reverse operations.
- Reverse prohibition against command <b-08>: "1"  
It prohibits the opposite direction to the operation command at inverter start.  
Once the inverter starts, the opposite direction to the command at start is prohibited until it stops. Even when you switch the forward start and the reverse start command after start, the direction does not change unless the inverter stops.

	Positive frequency/speed command	Negative frequency/speed command
Start in the forward operation	Forward operation	Limited to the positive minimum frequency
Start in the reverse operation	Reverse operation	Limited to the negative minimum frequency

- Reverse operation prohibition <b-08>: "2"  
It prohibits the reverse operation of the motor regardless of the direction of the operation command. Here, "forward operation" means the rotation direction where the phase sequence of the inverter output voltage is T1/U, T2/V, and then T3/W.  
The frequency/speed command of the reverse direction is limited to the positive minimum frequency/speed.

■ <b-09> through <b-12>

Frequency/speed, operation, JOG command input selection

Display	Contents	Setting range or selecting item	Initialized data	Unit	Driving ReWrite
b-09	Command_input_when_coupled	0: Terminal block 1: Console 2: Digital communication option	1	—	×
b-10	Frequency_command_input_selection/ Speed_command_input_selection	0: Interlocked 1: Analog input (1) terminal [AIN1] 2: Console 3: Digital communication option 4: Analog input (2) <IO66-Z> or digital communication option terminal [AIN2] 5: Digital setting input option <BCD66-Z> 6: Analog input (3) <IO66-Z> terminal [AIN3] 7: Internal PLC	0	—	×
b-11	Operation_command_input_selection	0: Interlocked	0	—	×
b-12	JOG-command_input_selection	1: Terminal block 2: Console 3: Digital communication option			

Select frequency/speed, operation, and JOG command input.

You can also set these input places collectively with the Command\_input\_when\_coupled <b-09>.

The table below lists the input place for each command with a combination of the settings of <b-09> through <b-12>.

		Speed_command_input_selection <b-09>		
		0: Terminal block	1: Console	2: Digital communication option
Frequency_command_input_selection/Speed_command_input_selection <b-10>	0: Interlocked	Control board <VFC66-Z> terminal [AIN1]	<0.FrEF>/<0.SrEF> setting	Speed command by communication
	1: Terminal [AIN1]	Control board <VFC66-Z> terminal [AIN1]		
	2: Console	<0.FrEF>/<0.SrEF> setting		
	3: Digital communication option	Command by communication		
	4: Analog input (2) optional board terminal [AIN2]	<IO66-Z> and others		
	5: Digital setting input option	<BCD66-Z>		
	6: Analog input (3) optional board terminal [AIN3]	<IO66-Z>		
	7: Internal PLC	Internal PLC		
Operation command <b-11>	0: Interlocked	Set the control board <VFC66-Z>, the control input terminal [ST-F], and the multifunction input terminal to the start command (reverse)	Console [START] [FOR/REV] key	Operation command by communication
	1: Terminal block	Set the control board <VFC66-Z>, the control input terminal [ST-F], and the multifunction input terminal to the start command (reverse)		
	2: Console	Console [START] [FOR/REV] key		
	3: Digital communication option	Operation command by communication		
JOG command <b-12>	0: Interlocked	Set the control board <VFC66-Z> and the multifunction input terminal to the JOG command (forward), (reverse)	Console [JOG/→] [FOR/REV] key	JOG command by communication
	1: Terminal block	Set the control board <VFC66-Z> and the multifunction input terminal to the JOG command (forward), (reverse)		
	2: Console	Console [JOG/→] [FOR/REV] key		
	3: Digital communication option	JOG command by communication		

- [V/f]  
When the frequency command is set to the terminal block, you can switch input characteristics (0 to  $\pm 10$  V voltage input, 0 to +10 V voltage input, 4 to 20 mA current input) with the Analog\_speed\_command\_characteristic\_selection <b-17>.  
In the factory default setting, 0 to  $\pm 10$  V voltage input is selected.
- [IM] [EDM]  
When the speed command is set to the terminal block, you can switch input characteristics (0 to  $\pm 10$  V voltage input, 0 to +10 V voltage input, 4 to 20 mA current input) with the Analog\_speed\_command\_

characteristic\_selection <b-17>.

In the factory default setting, 0 to  $\pm 10$  V voltage input is selected.



## WARNING Using control input terminal [ST-F]

- When you turn on the power or perform protection reset with signals input in the control input terminal [ST-F], the motor suddenly restarts. After checking that no signal is input in the control input terminal [ST-F], turn on the power or perform protection reset.

Otherwise, you may be injured.

### ■ <b-13> through <b-16>

[V/f] Torque limiter setting

Display	Contents	Setting range or selecting item	Initialized data	Unit	Driving ReWrite
b-13	Powering_torque_limit	0 to 150	150	%	○
b-14	Regenerative_torque_limit	-150 to 0	-150	%	○

#### Powering\_torque\_limit <b-13>

#### Regenerative\_torque\_limit <b-14>

Set the powering and regenerative torque limit values. When the torque command exceeds these values, it is limited to this setting value.

The torque limiter is based on calculated torque, and its accuracy is not guaranteed. Please use vector control mode [IM] or [EDM] if an accurate torque limiter is required.

The maximum (minimum) value in the setting range changes within the range of up to 200 % (-200 %) according to the rated current of your motor. When using the motor suited for the inverter capacity, it should be typically set to up to 150 % (-150 %).

[V/f] Torque limiter usage selection

Display	Contents	Setting range or selecting item	Initialized data	Unit	Driving ReWrite
b-15	Powering_torque_limit_usage_selection	OFF: Unused	ON	—	×
b-16	Regenerative_torque_limit_usage_selection	ON: Used			

#### Powering\_torque\_limit\_usage\_selection <b-15>

#### Regenerative\_torque\_limit\_usage\_selection <b-16>

When <b-15> or <b-16> is set to "ON," powering or regenerative torque is limited.

#### Powering side

If calculated torque exceeds Powering\_torque\_limit<b-13> to the powering side when <b-15> is "ON," acceleration of frequency is limited and frequency is lowered. In case of prohibiting reduction of frequency, enter "OFF" in <b-15>.

#### Regeneration side

If calculated torque exceeds Regenerative\_torque\_limit<b-14> to the regenerative side when <b-16> is "ON,"

deceleration of the frequency is limited.

[IM] [EDM] Torque limiter setting

Display	Contents	Setting range or selecting item	Initialized data	Unit	Driving ReWrite
b-13	Forward_powering_torque_limit	0 to Value depending on the Rated_motor_current <A-04>	150	%	○
b-14	Forward_regenerative_torque_limit	Value depending on -Rated_motor_current <A-04> to 0	-150	%	○
b-15	Reverse_powering_torque_limit	Value depending on -Rated_motor_current <A-04> to 0	-150	%	○
b-16	Reverse_regenerative_torque_limit	0 to Value depending on the Rated_motor_current <A-04>	150	%	○

**Forward\_powering\_torque\_limit <b-13>**

**Forward\_regenerative\_torque\_limit <b-14>**

**Reverse\_powering\_torque\_limit <b-15>**

**Reverse\_regenerative\_torque\_limit <b-16>**

For [IM] and [EDM], you can set powering and regenerative torque limit values for each forward and reverse operation. When the torque command exceeds these values, it is limited to this setting value.

The maximum (minimum) value of torque limit is calculated for VF66B-2R222 through 5522 and 2R244 through 5544 as follows:

$200 \times (\text{Rated inverter current}) / \text{Rated\_motor\_current} \langle \text{A-04} \rangle$

(However, when the calculated value exceeds 200 %, it should be 200 %).

It is calculated for VF66B-7522 through 18022 and 7544 through 100044 as follows:

$150 \times (\text{Rated inverter current}) / \text{Rated\_motor\_current} \langle \text{A-04} \rangle$

(However, when the calculated value exceeds 200 %, it should be 200%).

■ <b-17> through <b-19>

Analog speed command characteristic setting (control board <VFC66-Z> terminal [AIN1])

Display	Contents	Setting range or selecting item	Initialized data	Unit	Driving ReWrite
b-17	Analog_frequency_command_characteristic_selection/ Analog_speed_command_characteristic_selection	0: 0 to $\pm 10$ V (bipolar) 1: 0 to $\pm 10$ V (unipolar) 2: 4 to 20 mA	1	—	×

Display	Contents	Setting range or selecting item	Initialized data	Unit	Driving ReWrite
b-18	Analog_frequency_command_upper_limit_frequency/ Analog_speed_command_upper_limit_speed	Absolute value of the Analog_frequency_command_lower_limit_frequency/Analog_speed_command_lower_limit_speed <b-19> to 100.0	100.0	%	○
b-19	Analog_frequency_command_lower_limit_frequency/ Analog_speed_command_lower_limit_speed	-Analog_frequency_command_upper_limit_frequency/Analog_speed_command_upper_limit_speed <b-18> to Analog_frequency_command_upper_limit_frequency/Analog_speed_command_upper_limit_speed <b-18>	0.0	%	○

#### **Analog\_frequency\_command\_characteristic\_selection/Analog\_speed\_command\_characteristic\_selection <b-17>**

Select the frequency/speed command input to the analog input (1) terminal [AIN1] from voltage input (bipolar and unipolar) and current input.

You need to change the setting of the parameter and also the switch [SW1] on the control board <VFC66-Z>.

- When "2" (4 to 20 mA input) is used in <b-17>: "ON" (terminal block side)
- When "0" or "1" (voltage input) is used in <b-17>: "OFF" (console side)

Set it to "ON"/"OFF" using the tip of a pair of tweezers or a tool with a narrow tip (about 0.8 mm).

For the position of the switch [SW1], refer to {5.4.5 Analog Input (1) Gain Adjustment (For 4 to 20 mA Input Characteristic)}.

#### **Analog\_frequency\_command\_upper\_limit\_frequency/Analog\_speed\_command\_upper\_limit\_speed <b-18>**

#### **Analog\_frequency\_command\_lower\_limit\_frequency/Analog\_speed\_command\_lower\_limit\_speed <b-19>**

Set the value as a ratio to the Maximum\_frequency/Maximum\_speed <A-00>.

For settings of the frequency/speed command place selection, refer to the sections of the Command\_input\_when\_coupled <b-09> and the Frequency\_command\_input\_selection/Speed\_command\_input\_selection <b-10>.

### ◆When using analog input (1) terminal [AIN1] for frequency/speed command

The characteristics of the frequency/speed command input with analog input (1) are described below.

#### (1) Voltage input (0 to $\pm 10$ V): when <b-17> is "0"

A negative value of command input voltage will cause the inverter to be reversed.

However, when the inverter operates with the reverse operation command, a positive voltage value will cause it to be reversed and a negative voltage to be forwarded.

For +10 V input, a value specified in the Analog\_frequency\_command\_upper\_limit\_frequency/Analog\_speed\_command\_upper\_limit\_speed <b-18> is applied. For -10 V input, a negative value specified in the Analog\_frequency\_command\_upper\_limit\_frequency/Analog\_speed\_command\_upper\_limit\_speed <b-18> is applied. When a negative value smaller than a value specified in the Analog\_frequency\_command\_lower\_limit\_frequency/Analog\_speed\_command\_lower\_limit\_speed <b-19> is limited.

When using the negative maximum value, you need to set -100 % to the Analog\_frequency\_command\_lower\_limit\_frequency/Analog\_speed\_command\_lower\_limit\_speed <b-19>.

When the Minimum\_frequency/Minimum\_speed <A-01> is not "0," the absolute value is limited so that it is not below this frequency/speed. In this case, around 0 V, a hysteresis characteristic is observed as shown in the figure below.

When the inverter starts in the forward operation, the forward minimum frequency/speed is applied. When it starts in the reverse operation, the reverse minimum frequency/speed is applied.

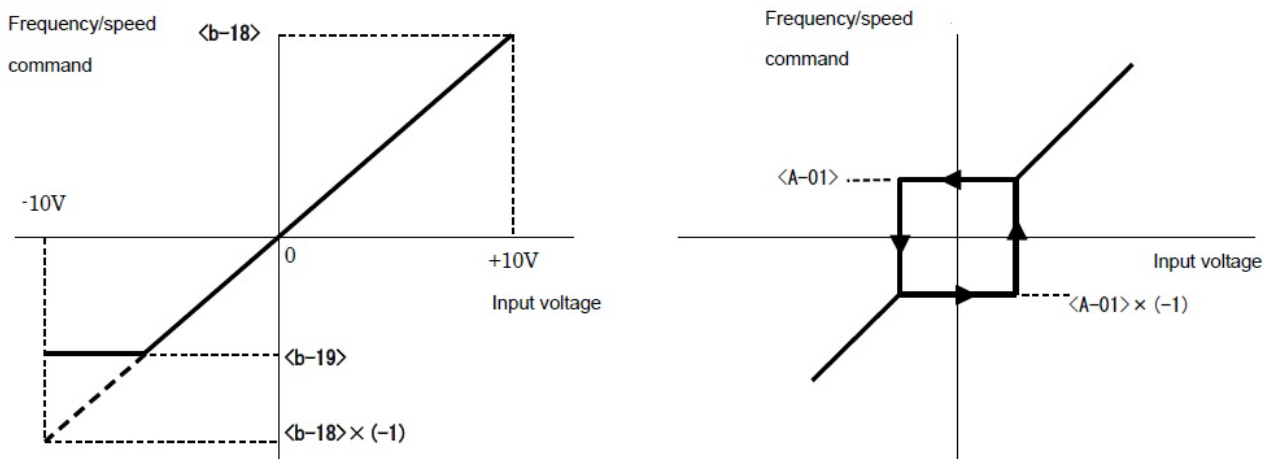

Selecting voltage input (0 to  $\pm 10$  V) [left] and Minimum frequency <A-01> hysteresis characteristic around 0 V [right]

#### (2) Voltage input (0 to 10 V): when <b-17> is "1"

For 0 V input, a value specified in the Analog\_frequency\_command\_lower\_limit\_frequency/Analog\_speed\_command\_lower\_limit\_speed <b-19> is applied. For 10 V input, a value specified in the Analog\_frequency\_command\_upper\_limit\_frequency/Analog\_speed\_command\_upper\_limit\_speed <b-18> is applied.

- Only positive voltage input is enabled. Negative voltage is limited to the Analog\_frequency\_command\_lower\_limit\_frequency/Analog\_speed\_command\_lower\_limit\_speed <b-19>.
- When a negative value is set in the Analog\_frequency\_command\_lower\_limit\_frequency/Analog\_speed\_command\_lower\_limit\_speed <b-19>, the frequency/speed command is "0."

When the Minimum\_frequency/Minimum\_speed <A-01> is not "0," the absolute value is limited so that it is not below this frequency/speed.

The frequency/speed command is enabled for forward operation only. For reverse operation, use the reverse operation command.

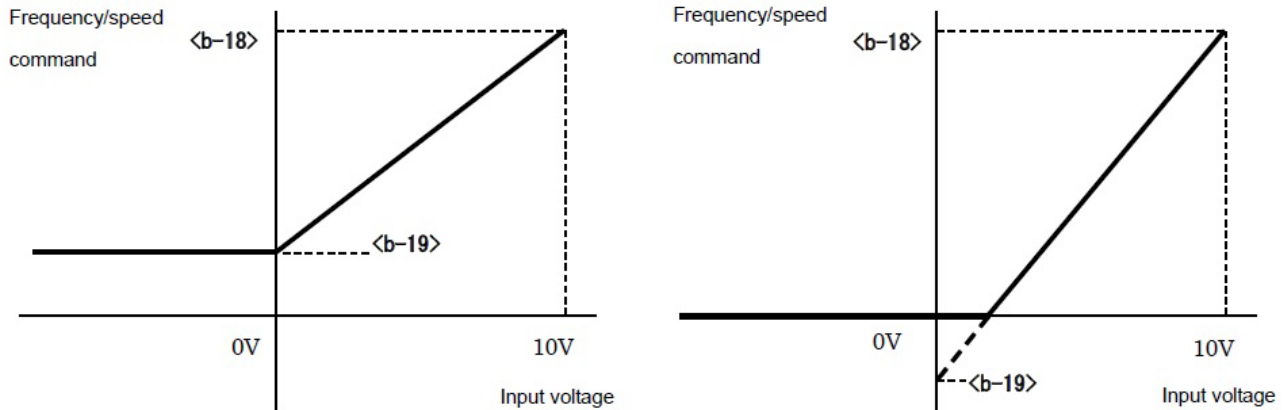

Selecting 0 to 10 V (<b-19> is set to

### (3) Current input (4 to 20mA): when <b-17> is "2"

For 4 mA input, a value specified in the Analog\_frequency\_command\_lower\_limit\_frequency/Analog\_speed\_command\_lower\_limit\_speed <b-19> is applied. For 20 mA input, a value specified in the Analog\_frequency\_command\_upper\_limit\_frequency/Analog\_speed\_command\_upper\_limit\_speed <b-18> is applied.

- Only positive current input is enabled. Negative current is limited to the Analog\_frequency\_command\_lower\_limit\_frequency/Analog\_speed\_command\_lower\_limit\_speed <b-19>.
- When a negative value is set in the Analog\_frequency\_command\_lower\_limit\_frequency/Analog\_speed\_command\_lower\_limit\_speed <b-19>, the frequency/speed command is "0."

When the Minimum\_frequency/Minimum\_speed <A-01> is not "0," the absolute value is limited so that it is not below this frequency/speed.

The frequency/speed command is enabled for forward operation only. For reverse operation, use the reverse operation command.

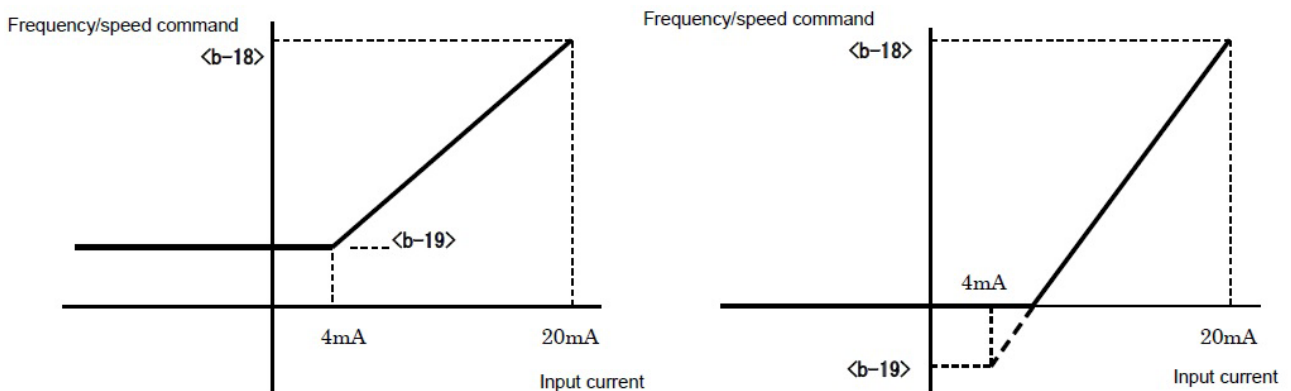

Selecting 4 to 20 mA (<b-19> is set to



## WARNING Safety notice

- Be sure to turn off the inverter before connecting terminals. Otherwise, it may result in a risk of electric shock.
- Close the front cover before turning on the power. Otherwise, it may result in a risk of electric shock.

## ■ &lt;b-20&gt;

Analog input zero limit setting

Display	Contents	Setting range or selecting item	Initialized data	Unit	Driving ReWrite
b-20	Analog_input_ ZeroLimit_voltage	0.000 to 1.000	0.000	V	○

**Analog\_input\_ZeroLimit\_voltage <b-20>**

The command is forcibly set to "0" when the absolute value of the command input voltage into the analog input (1) terminal [AIN1] on the control board <VFC66-Z> is less than or equal to this setting value.

Use it when a value does not become completely zero even if you set 0 V with analog circuit drift.

- [IM] [EDM]

It is enabled for both speed and torque commands.

## ■ &lt;b-21&gt;

Analog output (1) characteristic selection (control board &lt;VFC66-Z&gt; terminal [AOT1])

Display	Contents	Setting range or selecting item	Initialized data	Unit	Driving ReWrite
b-21	Analog_output(1)_ characteristic_selection	0: Output voltage 1: Output current 2: [V/f] Output torque [IM] [EDM] Torque command 3: Frequency/speed 4: Frequency/speed command 5: Internal PLC output 6: Calibration 7: Monitor for adjustment ----- -1: 6F frequency -2: 6F speed -3: 6F calibration	1	—	×

**Analog\_output(1)\_characteristic\_selection <b-21>**

Select analog output (1) data between the terminals [AOT1] and [GND] on the control board <VFC66-Z>.

Here, "6F" means a sixfold frequency signal. When "-2" (6F speed) or "-3" (6F calibration) is selected in <b-21>, a sixfold signal of the frequency conversion value is output. You cannot adjust gain and offset for 6F output.

Analog output and 6F output selected in the Analog\_output(1)\_characteristic\_selection

Selecting items		Output voltage/6F output
0	Output voltage	[200 V class] 7.5 V/200 V
		[400 V class] 7.5 V/400 V
1	Output current	5 V/rated inverter current

Selecting items		Output voltage/6F output
2	Torque command/output torque torque	5 V/100 %
3	Frequency/speed	10 V/Maximum_frequency and Maximum_speed <A-00>
4	Frequency/speed command (after acceleration and deceleration)	10 V/Maximum_frequency and Maximum_speed <A-00>
5	Internal PLC output	5 V/20000 (100 %)
6	Calibration	Output 5 V
7	Monitor for adjustment	—
-1	6F frequency	Output a sixfold frequency signal of the output frequency
-2	6F speed	Output a sixfold frequency signal of the value where speed is converted to frequency
-3	6F calibration	Output a sixfold frequency signal of the value equivalent to the Maximum_frequency and Maximum_speed <A-00>

(Note) For details of PLC output, refer to "Control Block Editor Function Manual."

#### ◆When 6F output is set in Analog\_output(1)\_characteristic\_selection

You need to change the setting of the parameter and also the switch [SW2] on the control board <VFC66-Z>. Follow the instructions below.

##### 1. Turn off the inverter.

##### 2. Open the front cover.

- For how to open the front cover, refer to {3.2 How to Open and Close Front Cover}.
- Use the Phillips screwdriver (M4).

##### 3. Turn the switch [SW2] to 1 (console board side).

- Use the tip of a pair of tweezers or a tool with a narrow tip (about 0.8 mm).

##### 4. Close the front cover.

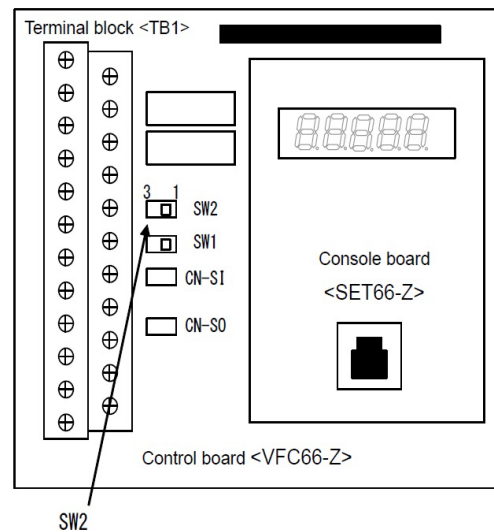

- When "-2" (motor speed) is selected in <b-21>  
The terminals [AOT1] - [GND] output a sixfold frequency signal (6F signal) of the frequency conversion value F shown in the figure below.  
The frequency conversion value F is calculated as follows:  
$$F = (\text{Motor speed})/60 \times (\text{Number of motor poles})/2 \text{ (Hz)}$$
- When "-3" (calibration) is selected in <b-21>  
A sixfold frequency signal is output. It is equivalent to the Maximum\_frequency and Maximum\_speed <A-00>.  
When using the digital counter type frequency/speed meter, turn the pulse count 1/6.

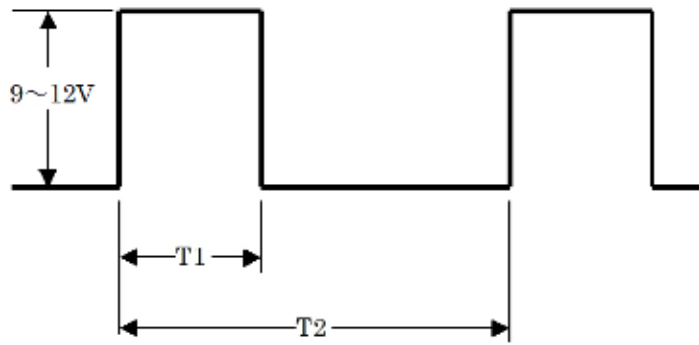

6F signal output waveform

T1 and T2 in the figure are described below.

T1 = 1 ms (when the frequency conversion value F of the maximum speed is 120 Hz or less)  
 = 0.5 ms (when the frequency conversion value F of the maximum speed is 240 Hz or less)  
 = 0.25 ms (when the frequency conversion value F of the maximum speed exceeds 240 Hz)

T2 =  $1/(6 \times F)$  where F is output frequency or a frequency conversion value



## WARNING Safety notice

- Be sure to turn off the inverter before connecting terminals.  
Otherwise, it may result in a risk of electric shock.
- Be sure to turn off the inverter before changing the switch.  
Otherwise, it may result in a risk of electric shock.
- Close the front cover before turning on the power.  
Otherwise, it may result in a risk of electric shock.

### 5.3.4 Area c (setting area for parameters related to multifunction input)

In the area c, you can set parameters related to the multifunction input on the terminal block of the inverter.

■ <c-00> through <c-17>

Display	Setting item	Selecting item	Initialized data	Unit	Driving ReWrite
c-00	Multifunction_input_place_selection	0: Terminal block 1: Digital communication option	0	—	×
c-01	Multifunction_input_terminal(1)_function_selection	0: Preset frequency/Preset speed selection 1	29	—	×
c-02	Multifunction_input_terminal(2)_function_selection	1: Preset frequency/Preset speed selection 2	30	—	×
c-03	Multifunction_input_terminal(3)_function_selection	2: Preset frequency/Preset speed selection 3	31	—	×
c-04	Multifunction_input_terminal(4)_function_selection <sup>*3</sup>	3: Acceleration or deceleration time selection 1	32	—	×
c-05	Multifunction_input_terminal(5)_function_selection	4: Acceleration or deceleration time selection 2	33	—	×
c-06	Multifunction_input_terminal(6)_function_selection	5: Frequency/speed UP command (MRH mode)	0	—	×
c-07	Multifunction_input_terminal(7)_function_selection	6: Frequency/speed DOWN command (MRH mode)	1	—	×
c-08	Multifunction_input_terminal(8)_function_selection	7: Frequency/speed hold	2	—	×
c-09	Multifunction_input_terminal(9)_function_selection	8: S-pattern acceleration/deceleration prohibition	3	—	×
c-10	Multifunction_input_terminal(10)_function_selection	9: Maximum frequency/Maximum speed reduction	4	—	×
c-11	Multifunction_input_terminal(11)_function_selection	10: Droop control disabled	5	—	×

Display	Setting item	Selecting item	Initialized data	Unit	Driving ReWrite
c-12	Multifunction_input_terminal(12)_function_selection	11: [V/f] - *1 [IM] [EDM] Speed/torque control selection	6	—	×
c-13	Multifunction_input_terminal(13)_function_selection	12: Forward/reverse operation command selection	7	—	×
c-14	Multifunction_input_terminal(14)_function_selection	13: DC brake command	8	—	×
c-15	Multifunction_input_terminal(15)_function_selection	14: [V/f] - [IM] [EDM] Initial excitation command	9	—	×
c-16	Multifunction_input_terminal(16)_function_selection	15: External failure signal 1 (Protection relay [86A] operation)	10	—	×

Display	Setting item	Selecting item	Initialized data	Unit	Driving ReWrite
c-17	Multifunction_input_terminal(17)_function_selection	16: External failure signal 2 (Protection relay [86A] operation) 17: External failure signal 3 (Protection relay [86A] operation) 18: External failure signal 4 (Protection relay [86A] operation) 19: External failure signal 1 (Protection relay [86A] not operated) 20: External failure signal 2 (Protection relay [86A] not operated) 21: External failure signal 3 (Protection relay [86A] not operated) 22: External failure signal 4 (Protection relay [86A] not operated) 23: Traceback external trigger 24: Second setting block selection 25: Emergency stop (Normally close) 26: —*1 27: Frequency/speed command terminal block selection 28: Start command (forward)*2 29: Start command (reverse) (STARTR) 30: JOG command (forward) (JOGF) 31: JOG command (reverse) (JOGR) 32: Emergency stop (Normally open) 33: Protection reset (RESET) 34: External signal input 1 35: External signal input 2 36: External signal input 3 37: External signal input 4 38: —*1 39: —*1	11	—	×

\* 1: Do not select this item.

\* 2: Do not select Start command [forward] because it is typically allocated to the control input terminal [ST-F].

\* 3: Even when the selecting item (24: Second setting block selection) is set to the Multifunction\_input\_terminal(4)\_function\_selection, the function will not be available.

**Multifunction\_input\_place\_selection <c-00>**

With "0" (Terminal block) set to the Multi\_function\_input\_place\_selection <c-00>, when values of the Multi\_function\_input\_terminals(1)\_function\_selection <c-01> through the Multi\_function\_input\_terminals(17)\_function\_selection <c-17> are set the functions.

The functions have been set can be controlled by turning the signals to the Multi\_function\_input\_terminals (1) through (17) "ON" and "OFF".

With "1" (Digital communication option) set to the Multifunction\_input\_place\_selection <c-00>, when values of the Multifunction\_input\_terminal(1)\_function\_selection <c-01> through the Multifunction\_input\_terminal(17)\_function\_selection <c-17> are set to "0" (Preset frequency selection 1) through "27" (Frequency command terminal block selection), these functions are controlled by signals from the digital communication option. Accordingly, the control from the terminal block is invalid.

Even if the Multi\_function\_input\_selection <c-00> is set to "1" (Digital communication option), the functions of "29" (operation command [reverse]) to "37" (external failure signal input 4) are controlled by terminal block.

**Multifunction\_input\_terminal(1)\_function\_selection through Multifunction\_input\_terminal(5)\_function\_selection <c-01> through <c-05>**

These parameters set the terminals [MI1] through [MI5] on the control board <VFC66-Z>.

**Multifunction\_input\_terminal(6)\_function\_selection through Multifunction\_input\_terminal(17)\_function\_selection <c-06> through <c-17>**

These parameters set the terminals [MI6] through [MI17] on the optional board.

**Priority of digital communication option and internal PLC function**

●When the PLCL\_function\_usage\_selection is set to "ON," any setting of the Multifunction\_input\_place\_selection is ignored.

The multifunction input terminals (1) through (5) ([MI1] through [MI5]) on the control board <VFC66-Z> and the multifunction input terminals (6) through (17) ([MI6] through [MI17]) on the optional board become an input relay terminal of the internal PLC function.

Each function of the multifunction input terminals is controlled by the internal PLC function.

●When the PLCL\_function\_usage\_selection <i-00> is set to "OFF" and the PLCH\_function\_usage\_selection <i-01> is set to "ON," the multifunction input terminal (4) [MI4] is set to "32" (Emergency stop (Normally open)), regardless of the setting of the Multifunction\_input\_terminal(4)\_function\_selection <c-04>.

**Examples of connection of multifunction input terminals (1) through (5)**

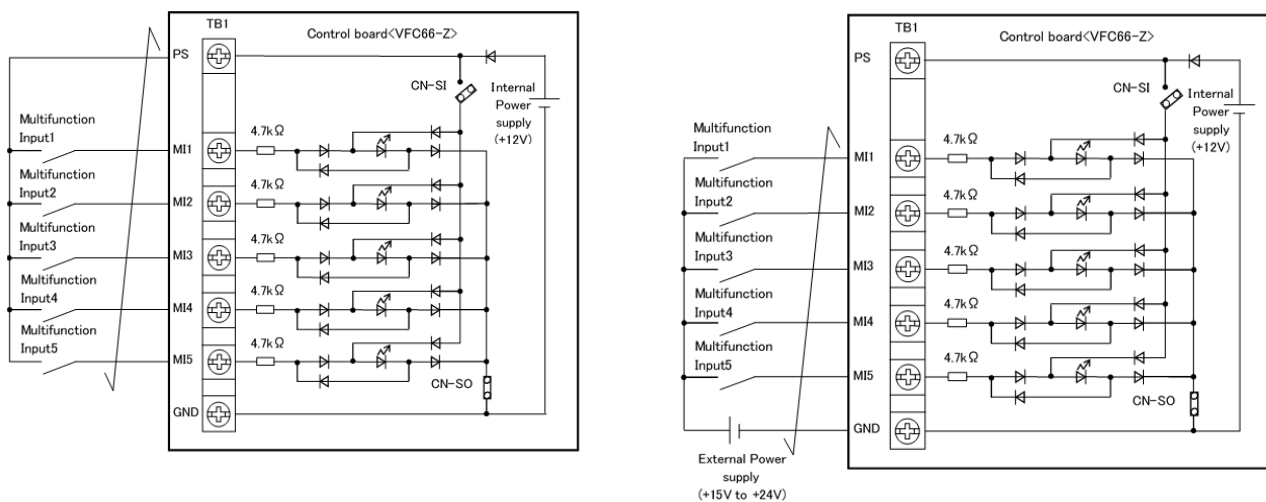

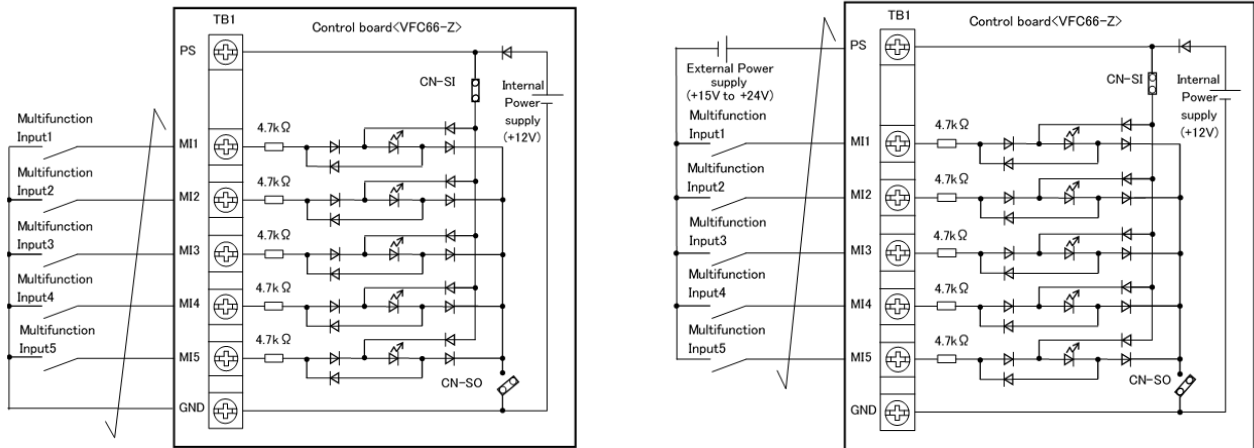

The above figures show typical connection examples of the multifunction input signals. The maximum permitted voltage is 24 V, and the maximum permitted current per terminal is 3 mA.

You can select source mode or sink mode for the multifunction input signals. Also, you can select internal or external power supply of the inverter for each mode.

- In the initial state, the source mode is selected.
- You can switch from the source mode to the sink mode (and vice versa) by changing the position of the jumper socket [CN-SO] and [CN-SI] on the control board <VFC66-Z>.

## ⚡ WARNING Safety notice

- Be sure to turn off the inverter before connecting terminals.  
It may result in a risk of electric shock.
- Close the front cover before turning on the power.  
It may result in a risk of electric shock.
- Be sure to turn off the inverter before handling the jumper.  
It may result in a risk of electric shock, injury, failure, or malfunction.

- **To use internal power supply when the jumper socket is positioned at [CN-SO]**  
Install a switch, etc. between the multifunction input terminals (1) through (5) ([MI1] through [MI5]) and the terminal [PS], and switch it on/off. Use a Phillips screwdriver (M3) to install it.
- **To use internal power supply when the jumper socket is positioned at [CN-SI]**  
Install a switch, etc. between the multifunction input terminals (1) through (5) ([MI1] through [MI5]) and the terminal [GND], and switch it on/off. Use a Phillips screwdriver (M3) to install it.

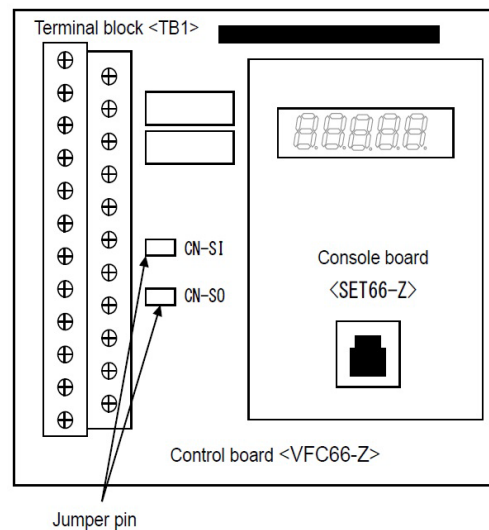

### Details of multifunction input settings

Details of each selecting item for the multifunction input terminals are described below.

#### ▪ Selecting item: 0 to 2

##### Preset frequency/Preset speed selection

The combination of Preset frequency/speed selections 1 through 3 turned on/off enables you to select a setting of the Preset\_frequency/speed(1) through the Preset\_frequency/speed(7) (<d-15> through <d-21>) and operate the inverter.

Preset frequency/ Preset speed selection 3	Preset frequency/ Preset speed selection 2	Preset frequency/ Preset speed selection 1	Frequency/speed command
OFF	OFF	OFF	As normally specified (preset function will not be used)
OFF	OFF	ON	<d-15> (Preset_frequency(1)/Preset_speed (1))
OFF	ON	OFF	<d-16> (Preset_frequency(2)/Preset_speed (2))
OFF	ON	ON	<d-17> (Preset_frequency(3)/Preset_speed (3))
ON	OFF	OFF	<d-18> (Preset_frequency(4)/Preset_speed (4))
ON	OFF	ON	<d-19> (Preset_frequency(5)/Preset_speed (5))
ON	ON	OFF	<d-20> (Preset_frequency(6)/Preset_speed (6))
ON	ON	ON	<d-21> (Preset_frequency(7)/Preset_speed (7))

#### ▪ Selecting item: 3, 4

##### Acceleration or deceleration time selection

You can use Acceleration or deceleration time selection 1 and 2 to change acceleration or deceleration time while the inverter is running.

To use S-pattern acceleration or deceleration, you should set the S-pattern\_acceleration/deceleration\_usage\_selection <d-06> to "ON."

Acceleration or deceleration time selection 2	Acceleration or deceleration time selection 1	Selected acceleration or deceleration time (including S-pattern acceleration or deceleration)
OFF	OFF	Normal (acceleration or deceleration time selected in <d-00>)
OFF	ON:	Acceleration_time(2) and Deceleration_time(2) (<5.Acc2>, <6.dEc2>, and <d-11> through <d-14>)
ON	OFF	Acceleration_time(3) and Deceleration_time(3) (<d-02> and <d-03> (without S-pattern acceleration or deceleration))
ON	ON	Acceleration_time(4) and Deceleration_time(4) (<d-04> <d-05> (without S-pattern acceleration or deceleration))

- **Selecting item: 5, 6**

- **Frequency UP and DOWN command (MRH mode)**

- **Speed UP and DOWN command (MRH mode)**

When the MRH\_function\_usage\_selection <d-27> is set to "ON", acceleration or deceleration can be controlled through an UP or DOWN command.

When frequency/speed exceeds its upper or lower limit, the inverter automatically accelerates or decelerates until it reaches the upper or lower limit without an UP or DOWN command. Specifying a negative value to the lower limit speed enables the inverter to operate in the opposite direction.

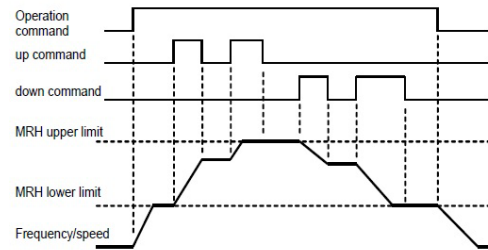

- **Selecting item: 7**

- **Frequency/speed hold**

When this signal is set to "ON" while the inverter is accelerating or decelerating, it temporarily stops acceleration or deceleration and holds the frequency/speed at that time. When it is changed to "OFF," the inverter will accelerate or decelerate again.

However, this hold function is not available while the inverter is decelerating to stop with a stop command.

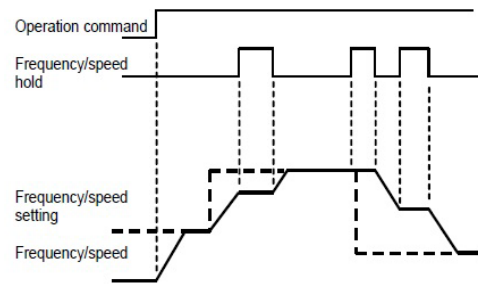

- **Selecting item: 8**

- **S-pattern acceleration or deceleration prohibition**

Even when the inverter executes S-pattern acceleration or deceleration with the S-pattern\_acceleration/deceleration\_usage\_selection set to "ON," setting this signal to "ON" will forcibly prohibit the S-pattern acceleration/deceleration and return the inverter to normal acceleration or deceleration.

- **Selecting item: 9**

- **Maximum frequency/Maximum speed reduction**

When "1" (Terminal block) is selected to the Frequency/Speed\_command\_input\_selection <b-10>, setting this signal to "ON" will cause Maximum frequency/speed to be reduced, based on a setting of the Maximum\_frequency/speed\_reduction\_rate <H-12>, as shown in the figure.

Change it to "ON"/"OFF" while the inverter stops. Even when it is changed while the inverter is running, the change will not take effect until the inverter stops.

This function is enabled only for analog input from the terminal block.

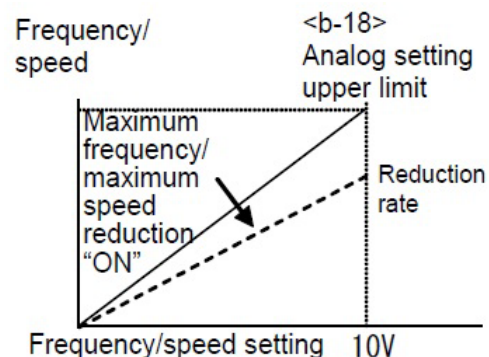

- **Selecting item: 10**

**Droop control disabled**

Even when the Droop\_control\_usage\_selection <i-02> is set to "ON," setting this signal to "ON" will cause the droop function not to be operated.

- **Selecting item: 11**

**[IM] [EDM] Speed/torque control selection**

When "4" (Speed/torque control contact change) is set to the Operation\_mode\_selection <i-07>, using this signal enables you to switch speed control to torque control and vice versa.

"OFF" enables the speed control, and "ON" enables the torque control.

- **Selecting item: 12**

**Forward/reverse operation command selection**

When "1" (Terminal block) is set to the Operation\_command\_input\_selection <b-11> or JOG-command\_input\_selection <b-12>, setting this signal to "ON" will switch between forward and reverse of the operation/JOG command.

- Forward operation will be changed to reverse, and reverse to forward.

When "1" is set to the Operation\_command\_input\_selection <b-11>, you should install a switch between the control input terminal [ST-F] and the terminal [PS] on the control board <VFC66-Z> and then set the operation signal to "ON"/"OFF."

- For details of how to install it, refer to {4.5 Start and Stop through External Contact in V/f Control}.

- **Selecting item: 13**

**DC brake command**

Setting this signal to "ON" will cause a DC brake which applies direct current to the motor.

You can adjust the current at this time with the following settings:

- [V/f]: DC\_brake\_voltage <8.dabr>
- [IM] [EDM] DC\_brake\_gain <b-04>

When this signal is set to "OFF," the motor will stop after the time specified in the DC\_brake\_operation\_time <b-03> has elapsed.

When an operation/JOG command is input together with the DC brake, the operation/JOG command is prioritized.

- **Selecting item: 14**

**[IM] [EDM] Initial excitation command**

Setting this signal to "ON" will cause an initial excitation operation which applies exciting current to the motor.

Use this function when exciting the motor for fast response time at start.

<b>Initial excitation operation mode</b>
--

For initial excitation operation, an "AC initial excitation mode" and "DC initial excitation mode" are provided. It can be selected in the Initial_excitation_selection <i-18>.
---

- **Selecting item: 15 through 18**

- **External failure signal (Protection relay [86A] operation)**

Use failure signals from peripherals as an input of this signal to protect and stop the inverter.

When External failure signals 1 through 4 are set to "ON," the inverter blocks output to turn on the protection relay [86A]. At the same time, "EF1" through "EF4" are displayed on the console, and traceback is also triggered.

To release the protection operation, reset it. To reset the protection operation, use the [STOP/RESET] key or set one of multifunction input terminals to protection reset and then turn it on.

- **Selecting item: 19 through 22**

- **External failure signal (Protection relay [86A] not operated)**

These are similar to the setting items 15 through 18 except that the protection relay [86A] does not operate. Also, traceback is not triggered for these signals.

Setting each command of operation/JOG/DC brake of the inverter to "OFF" will automatically release the protection operation.

- **Selecting item: 23**

- **Traceback external trigger**

Typically, traceback is triggered when a failure or protection operation occurs. Input of this signal can forcibly trigger it. For traceback, refer to {5.3.7 Area F}.

- **Selecting item: 24**

- **Second setting block selection**

Setting this signal to "ON" will cause each parameter specified in the second setting block to be used.

This setting is not available for the terminal [M14].

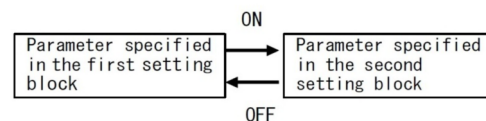

- **Selecting item: 25**

- **Emergency stop (Normally close)**

This is an emergency stop signal through Normally close contact input. When the contact is opened, the inverter urgently stops.

### Emergency stop setting

When this function is set to one of terminal blocks, the contact should be typically short circuited.

When the contact is opened, the inverter urgently stops and cannot operate.

- **Selecting item: 27**  
**Frequency/speed command terminal block selection**  
 When this signal is set to "ON," a frequency/speed command input will be forcibly set to the terminal block (terminal [AIN1] on the control board <VFC66-Z>), regardless of a setting of the Frequency/Speed\_command\_input\_selection <b-10>.  
 When this signal is input together with that of Preset frequency/Preset speed selection, this will be prioritized.  
 When <IO66-Z> or a digital communication option is installed, it will be forcibly changed from the terminal [AIN1] on the control board <VFC66-Z> to the terminal [AIN2] on <IO66-Z> or the digital communication optional board, regardless of a setting of the Digital\_communication\_option\_selection <J-00>.  
 Please note that a protection function of <IO66-Z> or a digital communication option does not work, when "0" (OFF) is set to the Digital\_communication\_option\_selection <J-00>.
- **Selecting item: 28**  
**Start command (forward) (STARTF)**  
 When "1" (Terminal block) is set to the Operation\_command\_input\_selection <b-11> and this signal is set to "ON," the motor starts running.  
 Do not set this function because it is allocated to the control input terminal [ST-F].
- **Selecting item: 29**  
**Start command (reverse) (STARTR)**  
 When "1" (Terminal block) is set to the Operation\_command\_input\_selection <b-11> and this signal is set to "ON," the motor starts running in reverse.
- **Selecting item: 30**  
**JOG command (forward) (JOGF)**  
 When "1" (Terminal block) is set to the JOG\_command\_input\_selection <b-12> and this signal is set to "ON," the motor jogs forward.
- **Selecting item: 31**  
**JOG command (reverse) (JOGR)**  
 When "1" (Terminal block) is set to the JOG\_command\_input\_selection <b-12> and this signal is set to "ON," the motor jogs in reverse.
- **Selecting item: 32**  
**Emergency stop (Normally open)**  
 This is an emergency stop signal through Normally open contact input. When the contact is short circuited, the inverter urgently stops.
- **Selecting item: 33**  
**Protection reset (RESET)**  
 Setting this signal to "ON" during the protection operation will release the protection operation.
- **Selecting item: 34 through 37**  
**External signal input**  
 These items send "ON" signals from peripherals to an optional board.  
 For details, refer to the "Instruction Manual" of the optional board.

**WARNING** Safety notice

- Be sure to turn off the inverter before connecting terminals.

It may result in a risk of electric shock.

- Close the front cover before turning on the power.

It may result in a risk of electric shock.

**WARNING** Using the start command (forward) of the control input terminal [ST-F] and multifunction input terminals

- When you turn on the power or perform protection reset with signals input in a start command (forward) of the terminal [ST-F] or multifunction input terminals, the motor suddenly restarts. After checking that no signal is input in a start command (forward) of the terminal [ST-F] or multifunction input terminals, turn on the power or perform protection reset.

Otherwise, you may be injured.

### 5.3.5 Area d (setting area for acceleration or deceleration time, frequency/speed jump functions, and MRH functions)

In the area d, you can set parameters related to acceleration or deceleration time, frequency/speed preset or jump functions, and MRH functions (acceleration/deceleration function by contact input) of the inverter.

#### ■ <d-00> through <d-14>

Selection and setting of acceleration or deceleration time

Display	Contents	Setting range or selecting item	Initialized data	Unit	Driving ReWrite
d-00	Acceleration/Deceleration_time_selection	0: Acceleration/Deceleration time (1)	0	—	×
d-01	JOG_acceleration/deceleration_time_selection	1: Acceleration/Deceleration time (2) 2: Acceleration/Deceleration time (3) 3: Acceleration/Deceleration time (4)	1	—	×
d-02	Acceleration_time(3)	0.0 to 3600.0	30.0	sec	○
d-03	Deceleration_time(3)				
d-04	Acceleration_time(4)	0.0 to 3600.0	30.0	sec	○
d-05	Deceleration_time(4)				
d-06	S-pattern_acceleration/deceleration_usage_selection	OFF: Unused ON: Used	OFF	—	×
d-07	S-pattern_rise_time(1)	0.0 to 60.0	0.1	sec	○
d-08	S-pattern_acceleration_reach_time(1)				
d-09	S-pattern_fall_time(1)				
d-10	S-pattern_deceleration_reach_time(1)				
d-11	S-pattern_rise_time(2)	0.0 to 60.0	0.1	sec	○
d-12	S-pattern_acceleration_reach_time(2)				
d-13	S-pattern_fall_time(2)				
d-14	S-pattern_deceleration_reach_time(2)				

#### Acceleration/Deceleration\_time\_selection <d-00>

#### JOG\_acceleration/deceleration\_time\_selection <d-01>

Select a setting of acceleration/deceleration time used for normal or JOG operation.

A setting of acceleration/deceleration time for normal operation can be changed through multifunction input.

Items selected in <d-00>, <d-01>, or multifunction input	Acceleration time	Deceleration time	S-pattern rise time	S-pattern acceleration reach time	S-pattern fall time	S-pattern deceleration reach time
0: Acceleration/deceleration time (1)	3.Acc1	4.dEc1	d-07	d-08	d-09	d-10
1: Acceleration/deceleration time (2)	5.Acc2	6.dEc2	d-11	d-12	d-13	d-14
2: Acceleration/deceleration time (3)	d-02	d-03	0.0	0.0	0.0	0.0
3: Acceleration/deceleration time (4)	d-04	d-05	0.0	0.0	0.0	0.0

The Acceleration\_time(1) <3.Acc1>, Deceleration\_time(1) <4.dEc1>, Acceleration\_time(2) <5.Acc2>, and Deceleration\_time(2) <6.dEc2> are items of the basic setting area.

When the Acceleration/Deceleration time (3) or (4) is selected, the amount of time related to S-pattern acceleration/deceleration will all become "0.0."

As shown in the figure below, these acceleration/deceleration time settings consist of the acceleration/deceleration time and the amount of time represented as S-pattern curves from "0" to the setting of the Maximum\_frequency/Maximum\_speed.

- To use the S-pattern acceleration or deceleration function, you should set the S-pattern\_acceleration/deceleration\_usage\_selection <d-06> to "ON."
- When it is set to "OFF," S-pattern acceleration/deceleration is not executed even if each S-pattern acceleration/deceleration time is specified.

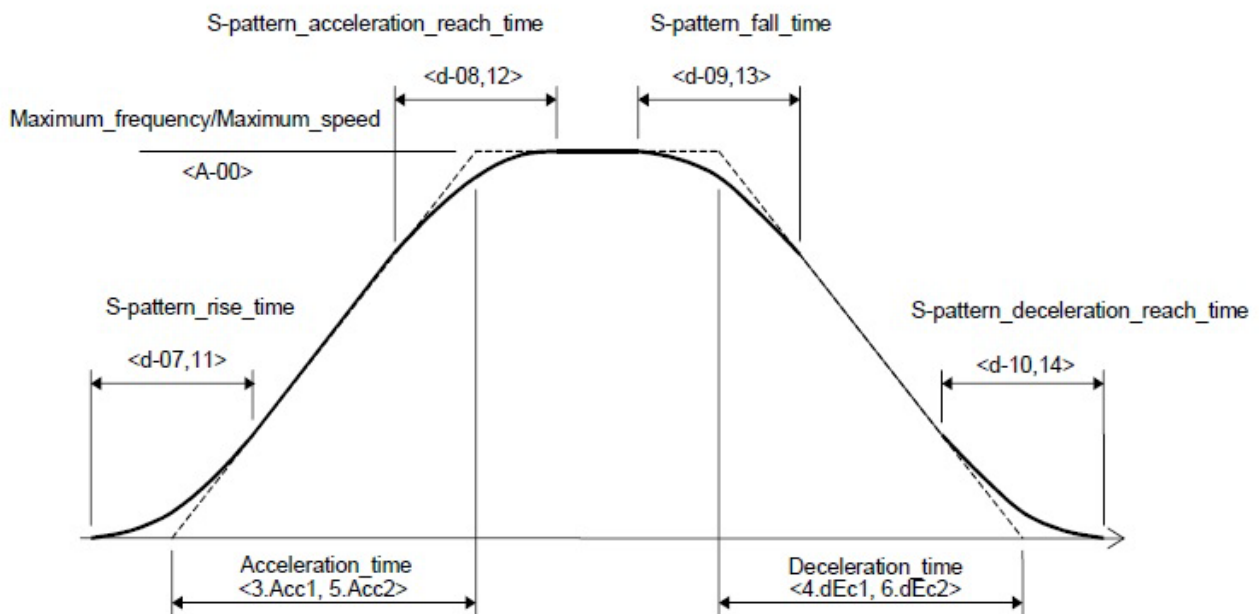

Time chart of acceleration/deceleration (S-pattern acceleration/deceleration)

## ■ &lt;d-15&gt; through &lt;d-21&gt;

## [V/f] Setting of preset operation frequency command

Display	Contents	Setting range or selecting item	Initialized data	Unit	Driving ReWrite
d-15	Preset_frequency(1)	-Maximum_frequency <A-00> to +Maximum_frequency <A-00>	0.0	Hz	○
d-16	Preset_frequency(2)				
d-17	Preset_frequency(3)				
d-18	Preset_frequency(4)				
d-19	Preset_frequency(5)				
d-20	Preset_frequency(6)				
d-21	Preset_frequency(7)				

## [IM] [EDM] Setting of preset operation speed command

Display	Contents	Setting range or selecting item	Initialized data	Unit	Driving ReWrite
d-15	Preset_speed(1)	-Maximum_speed <A-00> to +Maximum_speed <A-00>	0	r/min	○
d-16	Preset_speed(2)				
d-17	Preset_speed(3)				
d-18	Preset_speed(4)				
d-19	Preset_speed(5)				
d-20	Preset_speed(6)				
d-21	Preset_speed(7)				

These are frequency/speed command settings of preset operation functions selected by multifunction input signals.

For preset operations selected by multifunction input signals, refer to {5.3.4 Area c}.

## [V/f] Frequency command jump function setting

Display	Contents	Setting range or selecting item	Initialized data	Unit	Driving ReWrite
d-22	Jump_frequency(1)	0.0 to Maximum_frequency <A-00>	0.0	Hz	○
d-23	Jump_frequency(2)				
d-24	Jump_frequency(3)				
d-25	Jump_frequency(4)				
d-26	Jump_frequency_width	0.0 to 10.0	0.0	Hz	○

## [IM] [EDM] Speed command jump function setting

Display	Contents	Setting range or selecting item	Initialized data	Unit	Driving ReWrite
d-22	Jump_speed(1)	0 to Maximum_speed <A-00>	0	r/min	○
d-23	Jump_speed(2)				
d-24	Jump_speed(3)				
d-25	Jump_speed(4)				
d-26	Jump_speed_width	0 to 300	0	r/min	○

To avoid resonance point speed caused by load machines, use these functions to jump frequency/speed commands.

As shown in the figure below, they are jumped at each point with hysteresis characteristics.

Frequency/speed commands, which are input to the acceleration/deceleration control, will be jumped.

Therefore, while the inverter is accelerating or decelerating, they pass within the jump width at a slope depending on acceleration or deceleration time settings.

Frequency/speed command

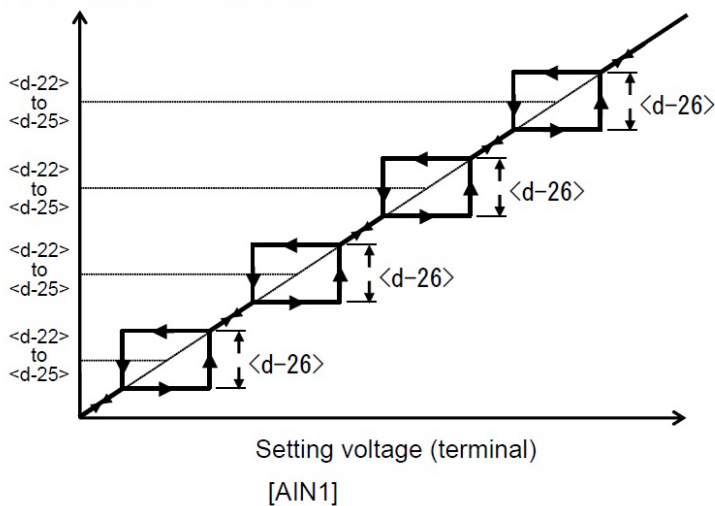

Frequency/speed command

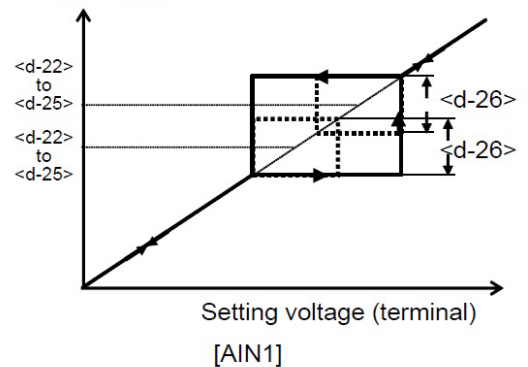

Frequency/speed command jump function [left], Multiple jumped areas are overlapped [right]

■ <d-27> through <d-29>

[V/f] MRH mode setting

Display	Contents	Setting range or selecting item	Initialized data	Unit	Driving ReWrite
d-27	MRH_function_usage_selection	OFF: Unused ON: Used	OFF	—	×
d-28	MRH_upper_limit_frequency	MRH_lower_limit_frequency <d-29> to Maximum_frequency <A-00>	5.0	Hz	○
d-29	MRH_lower_limit_frequency	-Maximum_frequency <A-00> to MRH_upper_limit_frequency <d-28>	0.0	Hz	○

[IM] [EDM] MRH mode setting

Display	Contents	Setting range or selecting item	Initialized data	Unit	Driving ReWrite
d-27	MRH_function_usage_selection	OFF: Unused ON: Used	OFF	—	×
d-28	MRH_upper_limit_speed	MRH_lower_limit_speed <d-29> to Maximum_speed <A-00>	300	r/min	○
d-29	MRH_lower_limit_speed	-Maximum_speed <A-00> to MRH_upper_limit_speed <d-28>	0	r/min	○

When the MRH\_function\_usage\_selection is set to "ON," acceleration or deceleration can be controlled through contacts. This is called the MRH mode.

When "1" (Terminal block) is set to the Frequency/Speed\_command\_input\_selection <b-10>, speed can be increased or decreased through multifunction input contacts.

For multifunction input, refer to {5.3.4 Area c}.

When an UP command is input, speed is increased to a setting value of the MRH\_upper\_limit\_frequency/speed <d-28>. When a DOWN command is input, speed is decreased to a setting value of the MRH\_lower\_limit\_frequency/speed <d-29>.

When UP and DOWN commands are not input or both are input, the inverter will keep the speed at that time. However, when the current frequency/speed is not between the setting values of the MRH\_upper\_limit\_frequency/speed <d-28> and of the MRH\_lower\_limit\_frequency/speed <d-29>, the inverter automatically accelerates or decelerates until it reaches that value.

By setting a negative value to the MRH\_lower\_limit\_frequency/speed <d-29>, you can operate the inverter in the opposite direction through contacts.

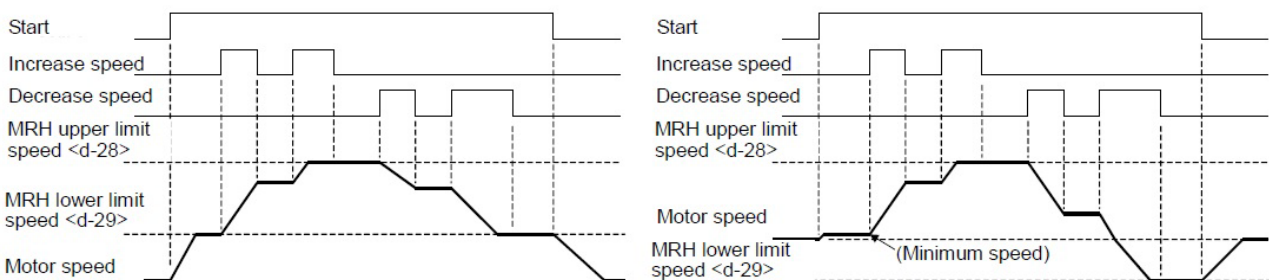

Motor speed when a positive value [left] or a negative value [right] is specified to the MRH\_lower\_limit\_frequency/speed

While the MRH mode is selected, when a multifunction input preset frequency/speed selection signal is input, a

frequency/speed command of multifunction input preset frequency/speed will be prioritized, and when a frequency/speed command terminal block selection signal is input, a frequency/speed command of frequency/speed command terminal block will be prioritized.

For the MRH mode selected by multifunction input signals, refer to {5.3.4 Area c}.

#### ■ [IM] [EDM] <d-30> through <d-32>

[IM] [EDM] Setting of speed deviation limiting function during acceleration/deceleration

Display	Contents	Setting range or selecting item	Initialized data	Unit	Driving ReWrite
d-30	Speed_deviation_limiting_command_selection	OFF: Without limiting command ON: With limiting command	OFF	—	○
d-31	Maximum_deviation(positive)	0.0 to 100.0	5.0	%	○
d-32	Maximum_deviation(negative)	-100.0 to 0.0	-5.0	%	○

#### Speed\_deviation\_limiting\_command\_selection <d-30>

#### Maximum\_deviation(positive) <d-31>

#### Maximum\_deviation(negative) <d-32>

When the Speed\_deviation\_limiting\_command\_selection <d-30> is set to "ON," output of motor speed and acceleration/deceleration control is limited to the deviation specified in the Maximum\_deviation(positive) <d-31> or Maximum\_deviation(negative) <d-32>.

These functions can prevent sudden acceleration caused by rapid change of load and power supply voltage and also restore speed at a slope specified in acceleration or deceleration time settings, for example, when the speed is decreased due to torque limit and the load is suddenly reduced while speed control operation. However, lowering deviation too much will cause acceleration or deceleration to be limited.

### 5.3.6 Area E (setting area for frequency characteristics, torque limit, torque command characteristics, and speed control)

In the area E, you can set parameters related to frequency characteristics, speed control, and torque of the inverter.

#### ■ <E-00>, <E-01>

Regeneration stall prevention function setting

Display	Contents	Setting range or selecting item	Initialized data	Unit	Driving ReWrite
E-00	Regeneration_stall_prevention_function_usage_selection	OFF: Unused ON: Used	OFF	—	×
E-01	Regeneration_stall_prevention_voltage	[200 V class] 320 to 365	345	V	○
		[400 V class] 640 to 730	690		

If direct-current voltage rises exceeding the setting value of the Regeneration\_stall\_prevention\_voltage, the torque command of regeneration (negative direction for forward and positive direction for reverse) is limited to 0. During deceleration, these functions can temporarily stop the deceleration to prevent the inverter from tripping due to an overvoltage (oV) protection operation.

When using these functions with the dynamic braking (DB) optional unit <VFDB2009>, it should set up in 200V class and more than 5V should set regeneration\_stall\_prevention\_voltage as the high level in 400V class more than 10V from the level of the dynamic braking (DB) optional unit <VFDB2009> operation level.

■ [V/f] <E-02>, <E-06>

[V/f] Start mode selection

Display	Contents	Setting range or selecting item	Initialized data	Unit	Driving ReWrite
E-02	Start_mode_selection	0: Free start 1: Minimum frequency start	1	—	×
E-06	Restart_delay_time	0.100 to 10.000	0.100	sec	×

**Start\_mode\_selection <E-02>**

Select "Free start" or "Minimum frequency start" as a start mode.

**Restart\_delay\_time <E-06>**

Specify a time lapse after stopping the inverter and before restarting it. Before the specified time has elapsed, the inverter will not restart even when the operation signal is set to "ON."

When you restart a motor with larger capacity immediately after stopping it, the inverter may fail to free-start due to magnetic flux remaining in the motor. In this case, set a larger value to the Restart\_delay\_time <E-06> for adjustment.

When the inverter is turned off at a frequency of 1/10 or less of the maximum frequency, it will start at the minimum frequency even if free start is selected.

A difference between "Free start" and "Minimum frequency start" is described below.

**Free start**

When an operation command is turned on while the motor rotates separately, the inverter starts at a frequency synchronized with the motor speed.

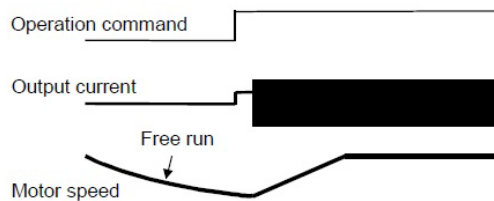

**Minimum frequency start**

The inverter starts at a frequency specified in the Minimum\_frequency <A-01> regardless of the motor rotation.

After instantaneous power interruption, it restarts at the same operation frequency as immediately before the power interruption is detected.

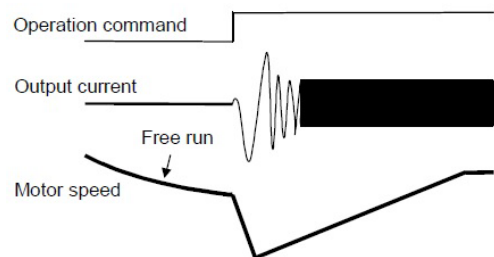

### ■ [IM] [EDM] <E-02>

[IM] [EDM] High-efficient operation mode selection

Display	Contents	Setting range or selecting item	Initialized data	Unit	Driving ReWrite
E-02	High-efficient_mode_usage_selection	OFF: Unused	[IM] OFF	—	×
		ON: Used	[EDM] ON		

### High-efficient\_mode\_usage\_selection <E-02>

[IM]

When running with small loads, the inverter adjust an excitation current command to achieve high-efficient operation.

Since the response of the inverter will be impaired by this function, you should set it to "OFF" when high-speed response is required.

[EDM]

When you set it to "OFF," output voltage has V/f constant characteristics. Typically, keep it "ON."

### ■ <E-03>

Motor rotation direction change setting

Display	Contents	Setting range or selecting item	Initialized data	Unit	Driving ReWrite
E-03	Forward_direction_change	OFF: Forward ON: Reverse	OFF	—	×

### Forward\_direction\_change <E-03>

Setting <E-03> to "ON" enables you to reverse the rotation direction of the motor without rewiring the inverter output terminals [T1/U, T2/V, and T3/W].

When "2" (Reverse prohibition) is set to the Reverse\_prohibition\_mode\_selection <b-08> with <E-03> set to "ON," forward rotation is prohibited.

### ■ <E-04>

Simulation mode setting

Display	Contents	Setting range or selecting item	Initialized data	Unit	Driving ReWrite
E-04	Simulation_mode	OFF: Without simulation operation ON: Simulation operation	OFF	—	×

### Simulation\_mode <E-04>

When <E-04> is set to "ON," the inverter can enter a simulation mode. In the simulation mode, the inverter virtually enters the operation mode without voltage output. Since voltage is not output in a simulation, a sequence check can be done with the inverter connected and without operating the motor.

■ <E-05>

[V/f] Boost mode selection

Display	Contents	Setting range or selecting item	Initialized data	Unit	Driving ReWrite
E-05	Autoboost_mode	OFF: Manual boost ON: Auto boost	OFF	—	×

**[V/f] Autoboost\_mode <E-05>**

In [V/f], output from the inverter can be boosted depending on the motor or load characteristics. You can select the following two boost modes:

**Manual boost**

Adjust the amount of boost with the Torque\_boost\_amount <7.tbSt> to suit motor load characteristics. When driving multiple motors, select Manual boost.

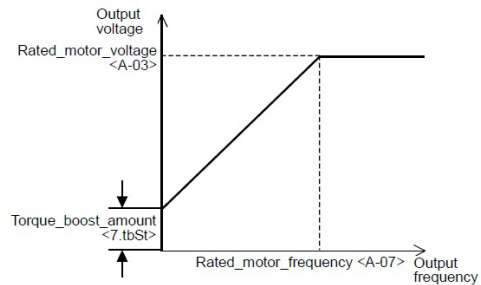

**Auto boost**

Automatically adjust the amount of boost depending on load. A setting of the Torque\_boost\_amount <7.tbSt> is not available.

Since deadtime compensation or primary resistance should be set with good accuracy, you should perform Autotuning when using it. For deadtime compensation or primary resistance, refer to {5.3.2 Area A}.

This cannot be used when multiple motors are driven.

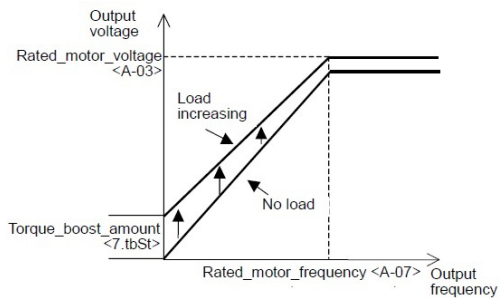

[IM] [EDM] Torque command mode selection

Display	Contents	Setting range or selecting item	Initialized data	Unit	Driving ReWrite
E-05	Torque_command_mode_selection	0: % torque command 1: Absolute value torque command	0	—	×

In [IM] and [EDM], select a torque command characteristic in the constant output (power constant) area. A difference between two types of torque commands is described below.

**% torque command**

Even when a torque command is constant, to keep output constant in the constant output (power constant) area, output torque is decreased inversely proportional to speed.

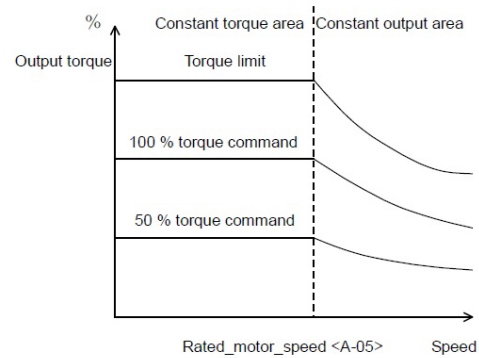
**Absolute value torque command**

When a command is constant even in the constant output (power constant) area, output torque is also constant. A value of torque limit is decreased to keep constant output.

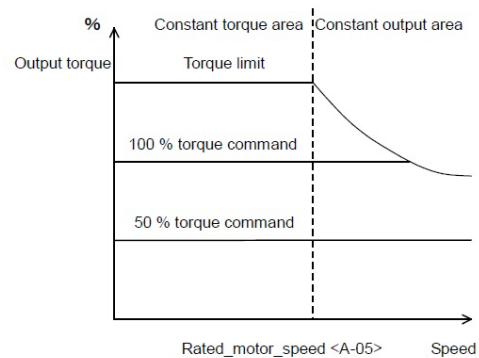

## ■ [V/f] &lt;E-06&gt;

Refer to the section of <E-02> in [V/f].

## ■ [IM] &lt;E-06&gt;

Refer to the section of <E-11> in [IM].

## ■ [EDM] &lt;E-06&gt;

[EDM] Restart prohibition time

Display	Contents	Setting range or selecting item	Initialized data	Unit	Driving ReWrite
E-06	Restart_prohibition_time	100 to 999	100	msec	○

**Restart\_prohibition\_time <E-06>**

Select the amount of time the inverter is prohibited from restarting. Normally, do not change its Initialized data.

■ <E-07> through <E-09>

[V/f] V/f pattern selection

Display	Contents	Setting range or selecting item	Initialized data	Unit	Driving ReWrite
E-07	V/f_pattern_selection	0: V/f constant straight line 1: Square reduction 2: Polygonal line	0	—	×
E-08	Voltage_at_turnoff_point	[200 V class] 0 to 230	0	V	×
		[400 V class] 0 to 460			
E-09	Frequency_at_turnoff_point	0.0 to Maximum_frequency <A-00>	0.0	Hz	×

Select a V/f pattern to suit load characteristics.  
A difference among three types of patterns is described below.

**V/f pattern: Straight line**

This is used when load has constant torque characteristics.

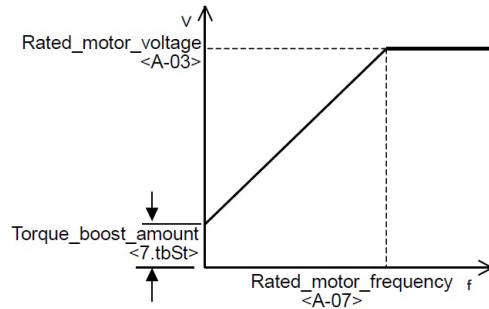

**V/f pattern: Square reduction**

This is effective when load has square reduction torque characteristics (for such as a fan and a pump).

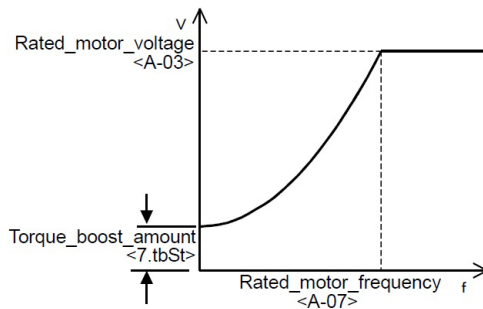

**V/f pattern: Polygonal line**

This is effective when load has two-step torque characteristics.

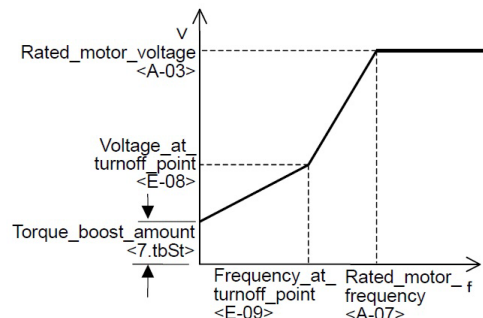

## [IM] [EDM] Current control gain adjustment

Display	Contents	Setting range or selecting item	Initialized data	Unit	Driving ReWrite
E-07	Current_control_proportion_gain	40.0 to 200.0	100.0	%	○
E-08	Current_control_integral_gain(1)	20.0 to 500.0	100.0	%	○
E-09	Current_control_integral_gain(2)				

These functions adjust current control gain. Normally, do not change its Initialized data.

## ■ [IM] [EDM] &lt;E-10&gt;

## [IM] [EDM] Motor temperature compensation usage selection

Display	Contents	Setting range or selecting item	Initialized data	Unit	Driving ReWrite
E-10	Motor_temperature_compensation	OFF: Without compensation ON: With compensation	OFF	—	×

**Motor\_temperature\_compensation <E-10>**

Set it to "ON" when temperature compensation is required, depending on motor temperature detected by a temperature sensor embedded in the motor.

The inverter control calculation function includes a motor temperature compensation calculation function, but it cannot calculate temperature before operation. Especially when start torque is required in a place where the motor becomes low temperatures while the inverter stops, this temperature detection option should be used to compensate start torque.

Using this function requires the temperature detection optional board for a PT100 internal motor <TVPT66-Z> or the temperature detection optional board for a thermistor internal motor <TVTH66-Z> and also the motor temperature sensor.

## ■ [IM] &lt;E-11&gt;, &lt;E-06&gt;

## [IM] Magnetic flux command adjustment

Display	Contents	Setting range or selecting item	Initialized data	Unit	Driving ReWrite
E-11	Flux_command	20.0 to 150.0	100.0	%	×
E-06	Flux_reinforcing_rate_at_start	100.0 to 150.0	100.0	%	×

**Flux\_command <E-11>**

This is a command value which indicates a size of magnetic flux used for vector control. Typically, set it to 100.0 %.

**Flux\_reinforcing\_rate\_at\_start <E-06>**

This is used when magnetic flux is reinforced only at start to enlarge start torque.

Typically, set it to 100.0 % (without reinforcing) because it may be instable depending on the motor.

## ■ [EDM] &lt;E-11&gt;

[EDM] Free start maximum speed setting

Display	Contents	Setting range or selecting item	Initialized data	Unit	Driving ReWrite
E-11	Free_start_maximum_speed	100 to 150	100	%	○

**Free\_start\_maximum\_speed <E-11>**

Specify the maximum speed, at which the inverter can start from free run, as a ratio to the Rated\_motor\_speed <A-05>.

This item cannot be set when it operates with the control without speed sensor.

## ■ [IM] [EDM] &lt;E-12&gt;

[IM] Motor cooling fan (drive without speed sensor) selection

Display	Contents	Setting range or selecting item	Initialized data	Unit	Driving ReWrite
E-12	Motor_cooling_fan (sensor-less_drive)	0: Self cooling fan 1: Forced air cooling fan	0	—	×

**Motor\_cooling\_fan(sensor-less\_drive) <E-12>**

Select "1" (Forced air cooling fan) when the motor cooling fan is driven by other motors. Select "0" (Self cooling fan) when it is directly connected to the motor shaft and the motor is cooled by rotation of the motor itself.

[EDM] Inverter maximum output voltage setting

Display	Contents	Setting range or selecting item	Initialized data	Unit	Driving ReWrite
E-12	Inverter_output_maximum_voltage	80 to 300	100	%	○

**[EDM] Inverter\_output\_maximum\_voltage <E-12>**

This is used to limit inverter output voltage. Specify a ratio to the Rated\_motor\_voltage <A-03>.

When rotation speed of the motor rises and output voltage exceeds a setting of the Inverter\_output\_maximum\_voltage <E-12> due to electromotive force caused by the permanent magnet embedded in the ED motor, this function executes magnetic flux weakening and limits output voltage.

### 5.3.7 Area F (setting area for built-in dynamic brake (DB) operation, protection functions, and traceback)

In the area F, you can set parameters related to dynamic brake operation, various protection functions, and traceback functions.

#### ■ <F-00>

Built-in DB(DynamicBrake) operation level setting

Display	Contents	Setting range or selecting item	Initialized data	Unit	Driving ReWrite
F-00	Built-in_DB(DynamicBrake)_operation_level	[200 V class] 320.0 to 360.0	340.0	V	○
		[400 V class] 640.0 to 720.0	680.0		

#### Built-in\_DB(DynamicBrake)\_operation\_level

VF66B-2R222 through 2222 [200 V class] and VF66B-2R244 through 2244 [400 V class] have a built-in dynamic brake (DB) transistor.

In <F-00>, set the operation level of this built-in dynamic brake (DB) transistor. When direct-current voltage becomes higher than a specified value, the built-in dynamic brake (DB) transistor turns on, and when lower, it turns off.

Normally, do not change its Initialized data. However, when power supply voltage is higher and it turns on even if it is not in the brake mode, you should set a larger value. When using it in combination with the sine wave converter, specify 360 V [200 V class] or 720 V [400 V class] to this setting item.

- When dynamic brake (DB) resistance and a thermal relay are connected between the direct-current terminals [+2] and [B] on the main circuit terminal block, dynamic brake will become effective. For the place and others of the terminal block, refer to {3.3.1 How to Connect Inverter Terminals}.
- Use a Phillips screwdriver or a hexagon box wrench (M4 through M12).



### WARNING Safety notice

- Be sure to turn off the inverter before connecting parts to terminals.

It may result in a risk of electric shock.

- Close the front cover before turning on the power.

It may result in a risk of electric shock.

## ■ &lt;F-01&gt; and &lt;F-02&gt;

## Overfrequency/overspeed protection setting

Display	Contents	Setting range or selecting item	Initialized data	Unit	Driving ReWrite
F-01	Forward_overfrequency_protection_setting/ Forward_overspeed_protection_setting	0.0 to 150.0	105.0	%	×
F-02	Reverse_overfrequency_protection_setting/ Reverse_overspeed_protection_setting	-150.0 to 0.0	-105.0	%	×

When output frequency/speed exceeds the settings of the Forward\_overfrequency/overspeed\_protection\_setting <F-01> and of Reverse\_overfrequency/overspeed\_protection\_setting <F-02> relative to the maximum frequency/speed, the overfrequency/overspeed protection function is activated to cause the inverter to trip. Set a value for forward and reverse each.

When changing a setting of the Maximum\_frequency/Maximum\_speed <A-00>, you should also review this setting.

 **WARNING** Overfrequency/overspeed protection setting

- In the Forward\_overfrequency/overspeed\_protection\_setting <F-01> and Reverse\_overfrequency/overspeed\_protection\_setting <F-02>, do not set a value significantly exceeding the rated motor speed. It may result in a risk of serious accidents.

## ■ &lt;F-03&gt;

## Overload protection setting

Display	Contents	Setting range or selecting item	Initialized data	Unit	Driving ReWrite
F-03	Overload_protection_setting	20 to 110	100	%	○

**Overload\_protection\_setting <F-03>**

Set a reference current value of overload protection as a ratio to the Rated\_motor\_current <A-04>. It starts when an effective value of output current exceeds a state where 150 % of the overload protection reference (rated motor current <A-04> × overload protection setting <F-03>) is output for over 60 seconds.

However, the overload protection reference is limited to the rated output current.

When an effective value of inverter output current exceeds 105 % of this reference current, this is considered as an overload situation, and an overload protection counter starts. As shown in the figure, an overload protection (oL) will be activated according to the 150 % - 60 sec characteristic curve.

The overload protection counter can be displayed on the console. Compared to an overtorque protection counter, the larger value is displayed.

A value of the overload protection counter is increased in the overload situation over time. When it reaches 100 %, an overload protection is activated to cause the inverter to trip.

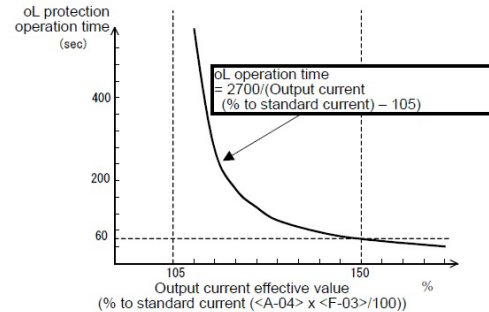

Overload protection (oL) operation time

### OL pre-alarm function

You can use an oL pre-alarm function to output signals when the overload counter exceeds a specified point. For details, refer to [5.3.9 Area H].

#### ■ <F-04>, <F-05>

Cumulative operation timer setting

Display	Contents	Setting range or selecting item	Initialized data	Unit	Driving ReWrite
F-04	Cumulative_operation_timer(1)(Main circuit capacitor life)	0 to 65535	43800	Hr	×
F-05	Cumulative_operation_timer(2)(Cooling fan life)	0 to 65535	21900	Hr	×

For changing monitor items and replacing the cooling fan, refer to {7.2 When [ALM] LED on Console Turns On} and {7.3 How to Replace Cooling Fan}.

## ■ &lt;F-06&gt;

Motor overheat protection

Display	Contents	Setting range or selecting item	Initialized data	Unit	Driving ReWrite
F-06	Motor_overheat_protection_operation_selection	OFF: Without protection operation ON: With protection operation	OFF	—	×

**Motor\_overheat\_protection\_operation\_selection <F-06>**

Select whether motor overheat protection is enabled or not.

Using this function requires <TVPT66-Z> or <TVTH66-Z> and the motor temperature sensor.

When <F-06> is set to "ON," the inverter trips in the following conditions:

- Motor temperature exceeds a setting of the Motor\_protect\_temperature <G-17>.

## ■ &lt;F-07&gt;

Protection relay [86A] operation setting upon power failure

Display	Contents	Setting range or selecting item	Initialized data	Unit	Driving ReWrite
F-07	Protection_relay(86A)_operation_selection_upon_power_failure	OFF: Without protection operation ON: With protection operation	OFF	—	×

**Protection\_relay(86A)\_operation\_selection\_upon\_power\_failure <F-07>**

Select a protection relay [86A] operation when the inverter detects power failure.

- When <F-07> is set to "OFF"

Even if the inverter detects power failure, a protection relay [86A] will not be activated. An operation command (or JOG command, DC brake command) is only set to "OFF" after the power is restored, and power failure is reset.

When the Instantaneous\_power\_interruption\_restart <b-07> is set to "ON," after the power is restored, power failure is automatically reset to restart the inverter.

- When <F-07> is set to "ON"

When the inverter detects power failure, the protection relay [86A] will be activated and the inverter will trip. In this case, like other protection operations, you should perform protection reset using reset terminals or the [STOP/RESET] key.

Even when the Instantaneous\_power\_interruption\_restart <b-07> is set to "ON," the inverter does not automatically restart.

**WARNING** About instantaneous power interruption restart

- If the Instantaneous\_power\_interruption\_restart <b-07> is set to "ON," the motor automatically restarts when the power is restored after instantaneous power interruption is detected. Therefore, do not come close to the motor while instantaneous power interruption is being detected.

Otherwise, you may be injured.

## ■ &lt;F-08&gt;

Protection retry function setting

Display	Contents	Setting range or selecting item	Initialized data	Unit	Driving ReWrite
F-08	Protection_retry_count_setting	0 to 5	0	Times	○

**Protection\_retry\_count\_setting <F-08>**

When a protection operation occurs, this function executes "auto protection reset" and "auto restart" the number of times which is specified in the Protection\_retry\_count\_setting <F-08>.

It executes auto reset in one second after the protection operation occurs, and then it executes auto restart. When another protection operation occurs within ten seconds after restart, the inverter increases a value of the retry counter by one. When the value is below a setting value of the Protection\_retry\_count\_setting <F-08>, the inverter resets the protection operation again to restart.

When a protection operation does not occur in ten seconds after auto restart, the inverter considers it as a successful retry and clears the retry counter.

For only the following protection operations, the protection retry can be performed: The retry against other protections is prohibited for safety reasons.

- Overvoltage protection
- Overspeed protection
- Overfrequency protection
- Power failure ([86A] is set to "ON")
- Optional error
- External failure (protection relay [86A] operation)

## ■ &lt;F-09&gt; through &lt;F-12&gt;

External failure detection delay time setting

Display	Contents	Setting range or selecting item	Initialized data	Unit	Driving ReWrite
F-09	External_failure(1)_detection_delay_time	0.0 to 30.0	0.0	sec	○
F-10	External_failure(2)_detection_delay_time				
F-11	External_failure(3)_detection_delay_time				
F-12	External_failure(4)_detection_delay_time				

Time required to detect external failure signals can be delayed during the amount of time specified in the External\_failure(1) through (4)\_detection\_delay\_time (<F-09> through <F-12>).

These are used to adjust detection sensitivity of external failure signals.

## ■ &lt;F-13&gt; through &lt;F-26&gt;

The inverter incorporates a traceback function which can store, read out, and analyze control data such as current and voltage of protection operations to rapidly restore it.

For data stored by the traceback function, you can specify current and voltage defined as Initialized data as well as output from each internal PLC when the PLCH function is used.

With the "VF66 PC Tool," you can read out traceback data on your personal computer. For details, refer to the "VF66PCTool Operating Manual."

Traceback function setting

Display	Contents	Setting range or selecting item	Initialized data	Unit	Driving ReWrite
F-13	Traceback_pitch	0 to 100	1	msec	○
F-14	Traceback_trigger_point	1 to 99	80	—	○
F-15	Traceback_CH1_selection	0 to 12	0	—	○
F-16	Traceback_CH2_selection				
F-17	Traceback_CH3_selection				
F-18	Traceback_CH4_selection				
F-19	Traceback_CH5_selection				
F-20	Traceback_CH6_selection				
F-21	Traceback_CH7_selection				
F-22	Traceback_CH8_selection				
F-23	Traceback_CH9_selection				
F-24	Traceback_CH10_selection				
F-25	Traceback_CH11_selection				
F-26	Traceback_CH12_selection				

**Traceback\_pitch <F-13>**

Set an interval of traceback.

**Traceback\_trigger\_point <F-14>**

Set a traceback trigger point.

**Traceback\_CH1 through CH12\_selection (<F-15> through <F-26>)**

Select whether each channel of traceback should be data within the inverter or a variable of the internal PLCc function.

The table below lists details of setting values.

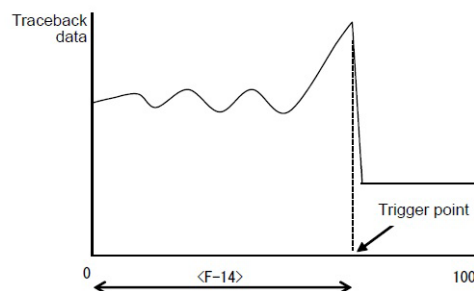

Traceback point setting

## Traceback pitch and traceback point settings

The traceback pitch and traceback point should be set before traceback data of protection operations and others is captured.

<F-15> to <F-26> set- tings	0		1 to 12	
	Recorded data	Dimension	Recorded data	Dimension
ch1	T1/U phase current	(3536/rated inverter current value)	PLC output RAM (1 through 12) • Settings of <F-15> through <F-26> become an output RAM selection.	20000/100 %
ch2	T2/V phase current			
ch3	T3/W phase current			
ch4	Direct-current voltage	[200 V class] 10/1 V		
ch5	Output voltage	[400 V class] 5/1 V		
ch6	[V/f] Unused	—		
	[IM] [EDM] Motor speed	20000/maximum speed		
ch7	[V/f] Frequency command (After acceleration and deceleration control)	20000/maximum frequency		
	[IM] [EDM] Speed control (After acceleration and deceleration control)	20000/maximum speed		
ch8	[V/f] Calculation torque	5000/100 %		
	[IM] [EDM] Torque command	5000/100 %		
ch9	Output frequency	20000/maximum frequency (Frequency corresponding to the maximum speed)		
ch10	[V/f] Unused	—		
	[IM] Slip frequency	20000/frequency corresponding to the maximum speed		
	[EDM] Motor d-axis current command	10000/100 %		
ch11	[V/f] Unused	—		
	[IM] Magnetic flux	1024/rated magnetic flux		
	[EDM] Motor q-axis current command	10000/100 %		
ch12	[V/f] [IM] Motor temperature	10/1°C		
	[EDM] Motor d-axis position	65536/360 degrees		

■ [IM] [EDM] <F-27> through <F-29>

[IM] [EDM] Overtorque protection setting

Display	Contents	Setting range or selecting item	Initialized data	Unit	Driving ReWrite
F-27	Overtorque_protection_function_selection	OFF: Without protection function ON: With protection function	ON	—	×
F-28	Overtorque_protection_level_setting	110 to 205	150	%	○
F-29	Overtorque_protection_operation_standard_torque	50 to 105	105	%	○

In <F-27> through <F-29>, set overtorque protections.

In the Overtorque\_protection\_function\_selection <F-27>, you can select whether protection operation is enabled or not.

When <F-27> is set to "ON," if a torque command exceeds a standard torque value specified in the Overtorque\_protection\_operation\_standard\_torque <F-29>, the inverter considers it as an overtorque condition and activate the overtorque protection counter.

As shown in the figure, when the torque command reaches a value specified in the Overtorque\_protection\_level\_setting <F-28>, an overtorque protection (oT) is activated at a curve of 60 seconds.

Like the overload protection (oL) counter, the overtorque protection counter can be displayed on the console. Compared with the overload protection counter, the larger value is displayed.

A value of the overtorque protection counter is increased in the overtorque condition over time. When it reaches 100 %, an overload protection is activated to cause the inverter to trip.

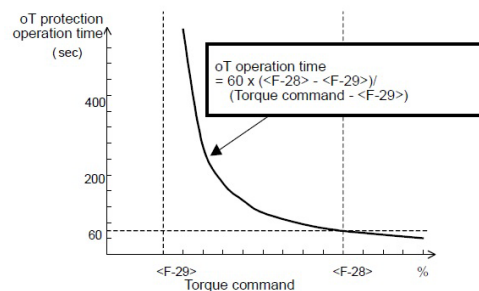

Overtorque protection (OT) operation time

### Overtorque protection compensation

For a torque command used for overtorque protection (oT), machine loss can be subtracted from an actual torque command for compensation.

For details, refer to {5.3.10 Area i}.

■ [IM] [EDM] <F-30> through <F-32>

[IM] [EDM] Speed control error protection setting

Display	Contents	Setting range or selecting item	Initialized data	Unit	Driving ReWrite
F-30	Speed_control_error_function_usage_selection	OFF: Without protection function ON: With protection function	OFF	—	×
F-31	Speed_control_error_detection_speed_width(positive)	2.0 to 30.0	5.0	%	○
F-32	Speed_control_error_detection_speed_width(negative)	-30.0 to -2.0	-5.0	%	○

In the Speed\_control\_error\_function\_usage\_selection <F-30>, you can select whether speed control error protection is enabled or not.

When <F-30> is set to "ON," if motor speed exceeds a range of  $\langle 0.SrEF \rangle + \langle F-32 \rangle$  through  $\langle 0.SrEF \rangle + \langle F-31 \rangle$  (in this case, a negative value is specified in <F-32>) relative to the Speed\_command  $\langle 0.SrEF \rangle$ , a speed control error occurs to cause the inverter to trip.

This protection is activated if the speed control part or PG has an abnormality or if speed is decreased when load torque exceeds a torque limit.

When "0" is set to the Operation\_mode\_selection <i-07>, a speed command selected in the Frequency/Speed\_command\_input\_selection <b-10> becomes a standard speed command.

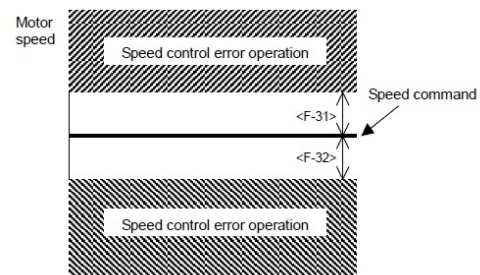

Operating range of speed control error protection function

### 5.3.8 Area G (setting area for analog input and output)

In the area G, you can set parameters related to analog input and output, including inverter temperature and others.

#### ■ <G-00>

Temperature detection selection (When <TVTH66-Z> and <TVPT66-Z> are used)

Display	Contents	Setting range or selecting item	Initialized data	Unit	Driving ReWrite
G-00	Temperature_detection_selection	0: None 1: Thermistor <TVTH66-Z> 2: PT100 <TVPT66-Z>	0	—	×

#### Temperature\_detection\_selection <G-00>

Select a motor temperature detector installed on the motor.

- When "0" is selected to <G-00>: Temperature is not detected.
- When "1" is selected to <G-00>: <TVTH66-Z> is used.
- When "2" is selected to <G-00>: <TVPT66-Z> is used.

For details, refer to the "Instruction Manual" of each option.

#### ■ <G-01> and <G-02>

Motor temperature detection adjustment (When <TVTH66-Z> and <TVPT66-Z> are used)

Display	Contents	Setting range or selecting item	Initialized data	Unit	Driving ReWrite
G-01	Temperature_detection_offset_adjustment	-20.0 to 20.0	0.0	%	○
G-02	Temperature_detection_gain_adjustment	50.0 to 150.0	100.0	%	○

Adjust offset and gain of temperature detected by the motor temperature compensation optional board <TVTH66-Z> or <TVPT66-Z>.

For details, refer to the "Instruction Manual" of each option.

#### ■ <G-03>

Analog input (2) characteristics selection (When <IO66-Z> and the digital communication option are used)

Display	Contents	Setting range or selecting item	Initialized data	Unit	Driving ReWrite
G-03	Analog_input(2)_characteristics_selection	0: 0 to $\pm 10$ V 1: 0 to 10 V 2: 4 to 20 mA	1	—	×

Select a type of input characteristics of the analog input (2) terminal [AIN2] on <IO66-Z> and the digital communication option.

When "2" is selected to the Analog\_input(2)\_characteristics\_selection <G-03>, switch operation will be required

on <IO66-Z> and the digital communication option.  
For details, refer to the "Instruction Manual" of each option.

#### ■ <G-04> and <G-05>

Analog input (2) limit setting (When <IO66-Z> and the digital communication option are used)

Display	Contents	Setting range or selecting item	Initialized data	Unit	Driving ReWrite
G-04	Analog_input(2)_upper_limit_frequency/speed	Absolute value of Analog_input(2)_lower_limit_frequency/speed <G-05> to 100.0	100.0	%	○
G-05	Analog_input(2)_lower_limit_frequency/speed	-Analog_input(2)_upper_limit_frequency/speed <G-04> to +Analog_input(2)_upper_limit_frequency/speed <G-04>	0.0	%	○

These settings are enabled when <IO66-Z> and the digital communication option are used.  
Set an upper limit or lower limit value of frequency/speed (as a ratio to the maximum frequency/speed) when analog input specified in the Analog\_input(2)\_characteristics\_selection <G-03> is input to the analog input terminal [AIN2] as a speed command.

- For forward direction, even when a speed command exceeding the frequency/speed specified in the Analog\_input(2)\_upper\_limit\_frequency/speed <G-04> is input to the terminal [AIN2], the frequency/speed is limited not to exceed that specified value.
- For reverse direction, the frequency/speed is limited so that it may not drop below the value specified in the Analog\_input(2)\_lower\_limit\_frequency/speed <G-05>.

For details, refer to the "Instruction Manual" of each option.

#### ■ <G-06>

Analog input (3) characteristics selection (When <IO66-Z> is used)

Display	Contents	Setting range or selecting item	Initialized data	Unit	Driving ReWrite
G-06	Analog_input(3)_characteristics_selection	0: 0 to $\pm 10$ V 1: 0 to 10 V 2: None 3: Pulse train (0 to 150 kHz)	1	—	×

Select a type of input characteristics of the analog input terminal [AIN3] on <IO66-Z>.

For details, refer to the optional "Instruction Manual."

For details of characteristics of analog input voltage (0 to  $\pm 10$  V, 0 to 10 V) and current (4 to 20 mA), refer to the sections of the Analog\_frequency\_command\_characteristic\_selection <b-17>, Analog\_frequency\_command\_upper\_limit\_frequency <b-18>, and Analog\_frequency\_command\_lower\_limit\_frequency <b-19>.

Pulse train input: When selecting "3" to <G-06>, move the position of the SW3 on <IO66-Z> to side 1, and input pulse signals with a duty ratio of 1:1 at a voltage of 0 to 15 V between the terminals [AIN3] and [G-IN].

Its setting characteristics are the same as those of voltage input (0 to 10 V). Refer to the descriptions related to (0 to 10 V) replacing 0 to 10 V with 0 to 150 kHz.



## WARNING Safety notice

- Be sure to turn off the inverter before connecting terminals.  
It may result in a risk of electric shock.
- Close the front cover before turning on the power.  
It may result in a risk of electric shock.

### ■ <G-07> and <G-08>

Analog input (3) limit setting (When <IO66-Z> is used)

Display	Contents	Setting range or selecting item	Initialized data	Unit	Driving ReWrite
G-07	Analog_input(3)_upper_limit_frequency/speed	Absolute value of Analog_input(3)_lower_limit_frequency/speed <G-08> to 100.0	100.0	%	○
G-08	Analog_input(3)_lower_limit_frequency/speed	-Analog_input(3)_upper_limit_frequency/speed <G-07> to +Analog_input(3)_upper_limit_frequency/speed <G-07>	0.0	%	○

These settings are enabled when <IO66-Z> is used.

Set an upper limit or lower limit value of frequency/speed (as a ratio to the maximum frequency/speed) when analog input specified in the Analog\_input(3)\_characteristics\_selection <G-06> is input to the analog input terminal (3) [AIN3] as a speed command.

For details, refer to the optional "Instruction Manual."

### ■ <G-09>

Analog output (2) characteristics selection (When <IO66-Z> and the digital communication option are used)

Display	Contents	Setting range or selecting item	Initialized data	Unit	Driving ReWrite
G-09	Analog_output(2)_characteristics_selection	0: Output voltage 1: Output current 2: [V/f] Output torque [IM] [EDM] Torque command 3: [V/f] Frequency [IM] [EDM] Motor speed 4: [V/f] Frequency command [IM] [EDM] Motor speed command 5: Internal PLC output 6: Calibration 7: Monitor for adjustment	1	—	×

For details, refer to the optional "Instruction Manual."

## ■ &lt;G-10&gt;

Analog output (3) characteristics selection (When &lt;IO66-Z&gt; is used)

Display	Contents	Setting range or selecting item	Initialized data	Unit	Driving ReWrite
G-10	Analog_output(3)_characteristics_selection	0: Output voltage 1: Output current 2: [V/f] Output torque [IM] [EDM] Torque command 3: [V/f] Frequency [IM] [EDM] Motor speed 4: [V/f] Frequency command [IM] [EDM] Motor speed command 5: Internal PLC output 6: Calibration 7: Monitor for adjustment 8: Output voltage (4 to 20 mA) 9: Output current (4 to 20 mA) 10: [V/f] Output torque (4 to 20 mA) [IM] [EDM] Torque command (4 to 20 mA) 11: [V/f] Frequency (4 to 20 mA) [IM] [EDM] Motor speed (4 to 20 mA) 12: [V/f] Frequency command (4 to 20 mA) [IM] [EDM] Motor speed command (4 to 20 mA) 13: Internal PLC output (4 to 20 mA) 14: Calibration (12 mA output)	0	—	×

For details, refer to the optional "Instruction Manual."

**Analog output selected in <G-09> (Selecting item 0 to 7)**  
**Analog output selected in <G-10> (Selecting item 0 to 14)**

Selecting items		Output voltage
0	Output voltage	[200 V class] 7.5 V/200 V
		[400 V class] 7.5 V/400 V
1	Output current	5 V/Rated inverter current
2	[V/f] Output torque	5 V/100 %
	[IM] [EDM] Torque command	
3	[V/f] Frequency	10 V/Maximum_frequency <A-00>
	[IM] [EDM] Motor speed	10 V/Maximum_speed <A-00>
4	[V/f] Frequency command (After acceleration and deceleration control)	10 V/Maximum_frequency <A-00>
	[IM] [EDM] Motor speed command (After acceleration and deceleration control)	10 V/Maximum_speed <A-00>
5	Internal PLC output	5 V/20000 (100 %)
6	Calibration	Output 5 V
7	Monitor for adjustment	—
8	Output voltage	[200 V class] 16 mA/200 V
		[400 V class] 16 mA/400 V
9	Output current	12 mA/Rated inverter current
10	[V/f] Output torque	12 mA/100 %
	[IM] [EDM] Torque command	
11	[V/f] Frequency	20 mA/Maximum_frequency <A-00>
	[IM] [EDM] Motor speed	20 mA/Maximum_speed <A-00>
12	[V/f] Frequency command (After acceleration and deceleration control)	20 mA/Maximum_frequency <A-00>
	[IM] [EDM] Motor speed command (After acceleration and deceleration control)	20 mA/Maximum_speed <A-00>
13	Internal PLC output	12 mA/20000 (100 %)
14	Calibration	Output 12 mA

For details, refer to the "Control Block Editor Function Manual."  
 For 4 to 20 mA output, refer to the optional "Instruction Manual."

■ <G-15>

Line speed setting

Display	Contents	Setting range or selecting item	Initialized data	Unit	Driving ReWrite
G-15	Line_speed_monitor_adjustment	0.0 to 2000.0	0.0	—	○

**Line\_speed\_monitor\_adjustment <G-15>**

Adjust the amount of gain of the monitor item (Line speed <L\_SP>) displayed on the console.  
Set the line speed at the time when a value of the Maximum\_frequency/speed <A-00> is reached.  
A value displayed in the line speed monitor is calculated in the following formula:

$$\text{Monitor speed} \times \text{Line\_speed\_monitor\_adjustment} \langle \text{G-15} \rangle / \text{Maximum\_frequency/speed} \langle \text{A-00} \rangle$$

**■ <G-16>**

Analog input monitor display selection

Display	Contents	Setting range or selecting item	Initialized data	Unit	Driving ReWrite
G-16	Analog_input_monitor_display_selection	1: Analog input (1) [AIN1] 2: Analog input (2) [AIN2] 3: Analog input (3) [AIN3] 4: Analog input (4) [AIN4] 5: Analog input (5) [AIN5]	1	—	○

**Analog\_input\_monitor\_display\_selection <G-16>**

Set an analog input channel in the monitor item (Analog input voltage <Vin>) displayed on the console.

- When "1" is selected to <G-16>: A value of voltage input into the analog input (1) terminal [AIN1] on the control board <VFC66-Z>
- When "2" is selected to <G-16>: A value of voltage input into the analog input (2) terminal [AIN2] on <IO66-Z> and the digital communication option

For changing monitor items and a list of them, refer to {4.1.6 Checking Operating State} and {4.1.7 List of Monitor Items}.

**■ <G-17>**

Motor protect temperature (When <TVPT66-Z> or <TVTH66-Z> is used)

Display	Contents	Setting range or selecting item	Initialized data	Unit	Driving ReWrite
G-17	Motor_protect_temperature	150 to 180	150	°C	○

**Motor\_protect\_temperature <G-17>**

This setting is enabled when the temperature detection option <TVPT66-Z> or <TVTH66-Z> is installed.  
When the Motor\_overheat\_protection\_operation\_selection <F-06> is set to "ON", set a temperature for activating the motor overheat protection.

Normally, do not change its Initialized data of 150 °C.

### 5.3.9 Area H (setting area for multifunction output)

In the area H, you can set parameters of inverter multifunction output.

■ <H-00> through <H-12>

Multifunction output setting item

Display	Setting item	Setting range or selecting item	Initialized data	Unit	Driving ReWrite
H-00	Multifunction_output_terminal(1)_function_selection	0: —	7	—	×
H-01	Multifunction_output_terminal(2)_function_selection	1: Frequency/speed detection (1) (Frequency/speed equal to detection setting)	1	—	×
H-02	Multifunction_output_terminal(3)_function_selection	2: Frequency/speed detection (1) (Frequency/speed more than or equal to the detection setting)	0	—	×
H-03	Multifunction_output_terminal(4)_function_selection	3: Frequency/speed detection (1) (Frequency/speed less than or equal to the detection setting)	8	—	×
H-04	Multifunction_output_terminal(5)_function_selection	4: Frequency/speed detection (2) (Frequency/speed equal to detection setting)	2	—	×

Display	Setting item	Setting range or selecting item	Initialized data	Unit	Driving ReWrite
H-05	Multifunction_output_terminal(6)_function_selection	5: Frequency/speed detection (2) (Frequency/speed more than or equal to the detection setting)  6: Frequency/speed detection (2) (Frequency/speed less than or equal to the detection setting)  7: Setting reached  8: Torque detection  9: Torque detection (absolute value)  10: During power failure  11: Overload protection pre-alarm  12: During retry  13: In reverse operation  14: Protection operation code  15: —  16: In operation  17: (For expanded options)  18: Timer 1 elapsed  19: Timer 2 elapsed  20: Second setting block being selected  21: Cooling fan failed  22: DB abnormal state	3	—	×
H-06	[V/f] Frequency_detection(1)	-Maximum_frequency <A-00> to +Maximum_frequency <A-00>	0.0	Hz	○
	[IM] [EDM] Speed_detection(1)	-Maximum_speed <A-00> to +Maximum_speed <A-00>	0	r/min	○
H-07	[V/f] Frequency_detection(2)	-Maximum_frequency <A-00> to +Maximum_frequency <A-00>	0.0	Hz	○
	[IM] [EDM] Speed_detection(2)	-Maximum_speed <A-00> to +Maximum_speed <A-00>	0	r/min	○
H-08	[V/f] Frequency_detection_width	0.0 to 10.0	0.0	Hz	○
	[IM] [EDM] Speed_detection_width	0 to 600	0	r/min	○
H-09	Torque_detection (with_polarity)	-205 to 205	0	%	○

Display	Setting item	Setting range or selecting item	Initialized data	Unit	Driving ReWrite
H-10	Torque_detection(absolute_value)	0 to 205	0	%	○
H-11	Overload_protection_pre-alarm_operation_level_setting	0 to 100	50	%	○
H-12	Maximum_frequency_reduction_rate	50.0 to 100.0	90.0	%	○

The multifunction output terminals (1) and (2) ([MO1] and [MO2]) on the control board <VFC66-Z> are set as output terminals of multifunction output functions specified in the Multifunction\_output\_terminal(1) through (6)\_function\_selection (<H-00> through <H-05>).

- [MO1] through [MO6] are open collector output terminals.

The multifunction output terminals (3) through (6) ([MO3] through [MO6]) are terminals on the optional board.

#### When the PLCL\_function\_usage\_selection <i-00> is set to "ON"

When the PLCL\_function\_usage\_selection <i-00> is set to "ON," the above setting items are ignored, and the multifunction output terminals ([MO1] through [MO6]) on the control board <VFC66-Z> and the optional board are used as output terminals from the PLC function.

Also, the multifunction output terminals described below can be used as input terminals to the PLC function.

### ◆ Connection of multifunction output terminals (1) through (2)

The figures below show typical connection examples of the multifunction output signals.

For the multifunction output, open collector transistor output is used. To use this, an external direct-current power supply is required. The maximum permitted voltage is 24 V, and the maximum permitted current per terminal is 20 mA.

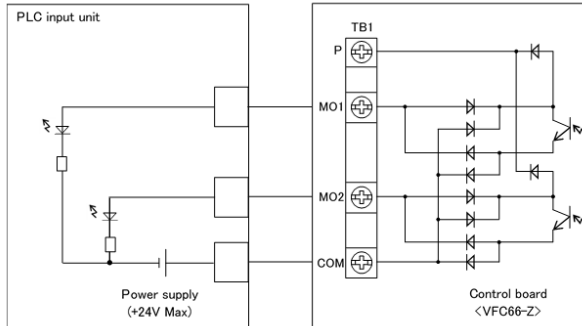

1.Connection with PLC (Source mode)

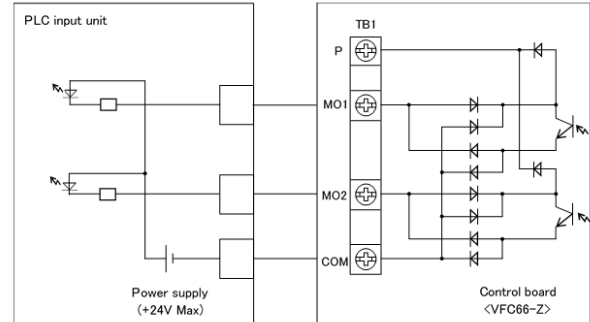

2.Connection with PLC (Sink mode)

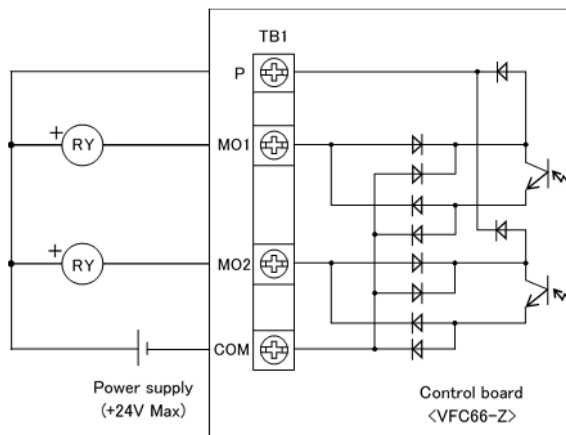

3.Connection with a relay

### Details of multifunction output settings

- **Selecting item: 1, 4**

#### **Frequency/speed detection (1) (2) (Frequency/speed equal to detection setting)**

When the frequency/speed becomes equal to the setting values of the Frequency/Speed\_detection(1) <H-06> and Frequency/Speed\_detection(2) <H-07> within the range from -Frequency/Speed\_detection\_width <H-08> to a +Frequency/Speed\_detection\_width <H-08>, output is enabled.

For output, a hysteresis width corresponding to 0.2 % of the setting of Maximum\_frequency/speed <A-00> is provided.

"Top" in the following figure indicates a value of the Maximum\_frequency/speed <A-00>.

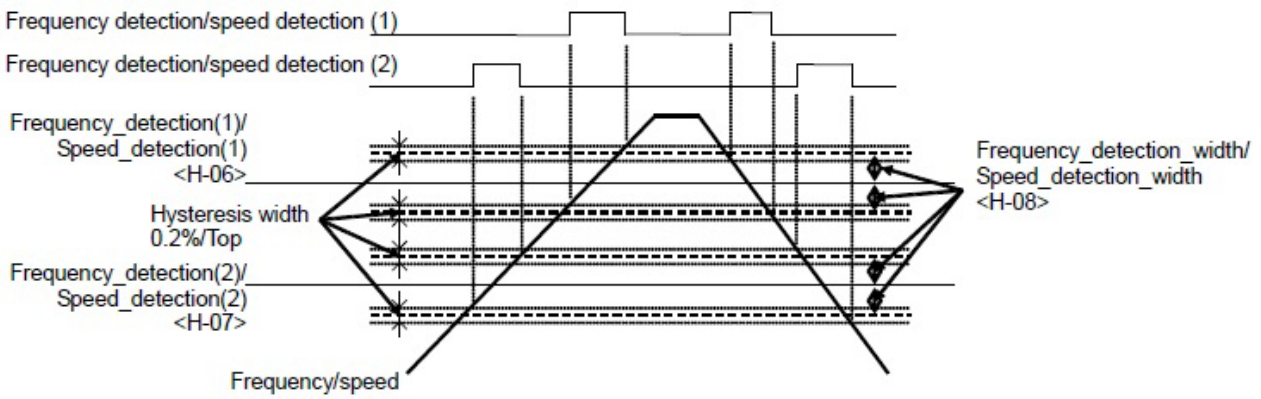

• **Selecting item: 2, 5**

**Frequency/speed detection (1) (2) (Frequency/speed more than or equal to the detection setting)**

When frequency/speed becomes larger than settings of the Frequency/Speed\_detection(1) <H-06> and Frequency/Speed\_detection(2) <H-07>, output is enabled.

Frequency/speed is detected as a signed number, not an absolute value.

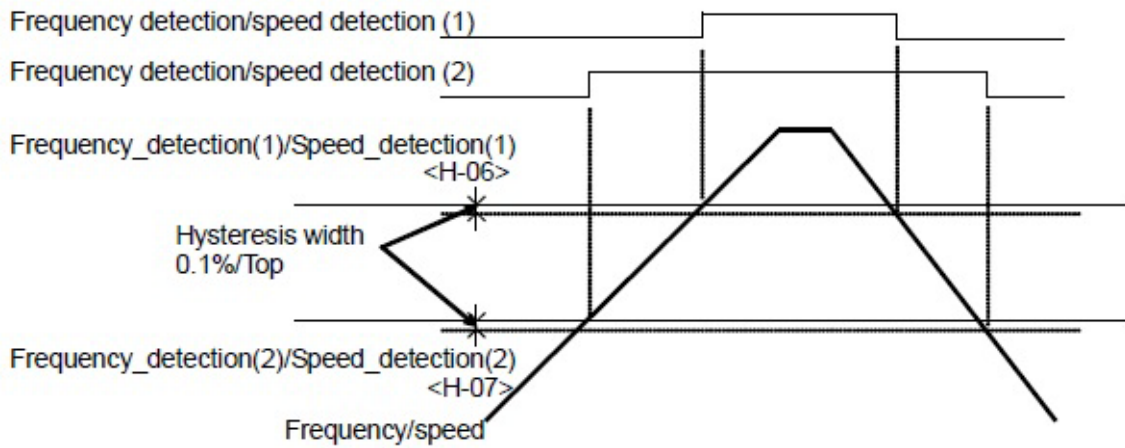

- **Selecting item: 3, 6**

**Frequency/Speed\_detection(1)(2) (Frequency/speed less than or equal to the detection setting)**

When frequency/speed becomes smaller than settings of the Frequency/Speed\_detection(1) <H-06> and Frequency/Speed\_detection(2) <H-07>, output is enabled.

Frequency/speed is detected as a signed number, not an absolute value.

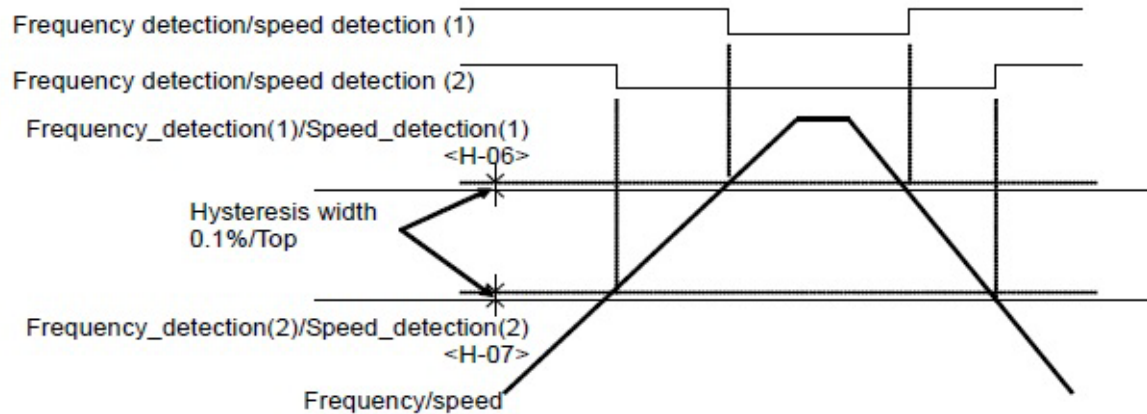

- **Selecting item: 7**

**Setting reached**

When frequency/speed reaches around a frequency/speed command value (within  $\pm 0.1\%$ ), output is enabled.

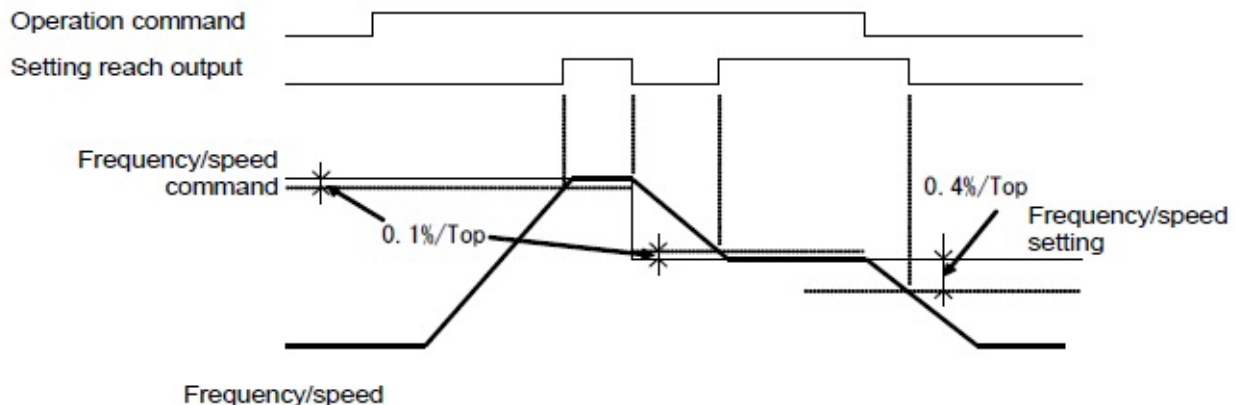

- **Selecting item: 8**

**Torque detection**

When a calculated torque/torque command becomes larger than a setting of the Torque\_detection(with\_polarity) <H-09>, output is enabled.

[V/f] does not assure the accuracy of calculated torque. When accuracy assurance of torque is required, the vector mode should be used.

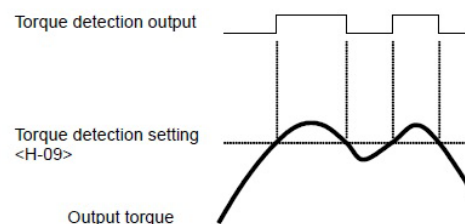

• **Selecting item: 9**

**Torque detection (absolute value)**

When an absolute value of a calculated torque/torque command becomes larger than a setting of the Torque\_detection(absolute\_value) <H-10>, output is enabled.

[V/f] does not assure the accuracy of calculated torque. When accuracy assurance of torque is required, the vector control should be used.

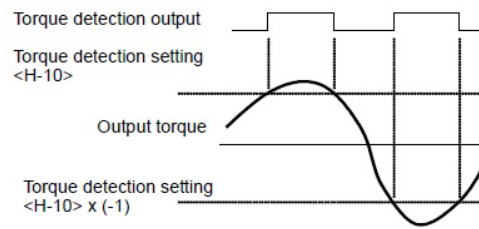

• **Selecting item: 10**

**During power failure**

When voltage of the direct-current part is in the following conditions, output is enabled:

- [200 V class]: 180 V or less
- [400 V class]: 360 V or less

When voltage of the direct-current part is in the following conditions, output is not available:

- [200 V class]: 200 V or higher
- [400 V class]: 400 V or higher

However, when power is no longer supplied from the control board <VFC66-Z>, output is not available.

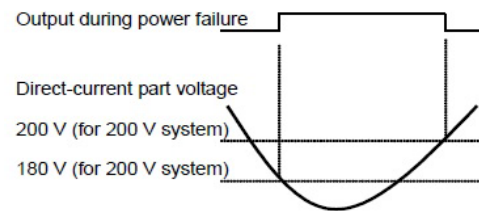

• **Selecting item: 11**

**Overload protection pre-alarm**

When an overload condition described in the section of the Overload\_protection\_setting <F-03> occurs and a value of the overload counter exceeds a level specified in the Overload\_protection\_pre-alarm\_operation\_level\_setting <H-11>, output is enabled.

A count value for activating overload protection (overtorque protection) shall be 100 %.

Suppose that the overload protection is set to be activated in a condition where 150 % of current is output for 60 seconds and that 50 % is set to the Overload\_protection\_pre-alarm\_operation\_level\_setting <H-11>. In this case, when 150 % of current is output for 30 seconds (i.e., 50 % of 60 seconds of the overload protection activation time), output is enabled.

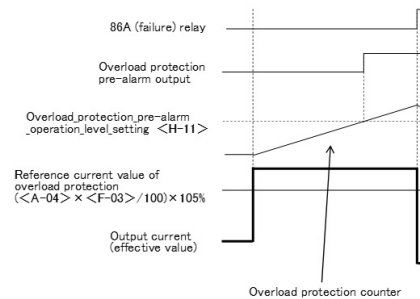

• **Selecting item: 12**

**During retry**

For ten seconds after the protection retry operation, output is enabled. For the protection retry operation, refer to the section of the area F.

• **Selecting item: 13**

**In reverse operation**

- [V/f]

When the output frequency is a negative value, output is enabled.

- [IM] [EDM]

When the motor is running in reverse, output is enabled. To prevent chattering, a hysteresis characteristic of 12 r/min (control without speed sensor or control with speed sensor) is provided around a speed of 0.

- **Selecting item: 14**

**Protection operation code**

When a failure occurs or a protection operation is activated, this function uses four multifunction output terminals to output a code corresponding to the activated protection.

Unlike other functions, this function requires four multifunction output terminals and you should set "Protection operation code" to all of them.

List of output code

Contents	MO1	MO2	MO3	MO4
Overcurrent protection	ON	OFF	OFF	OFF
IGBT protection operation	OFF	ON	OFF	OFF
Inverter overheat protection	OFF	ON	OFF	OFF
Gate board abnormality	OFF	ON	OFF	OFF
Charging resistance overheat protection	OFF	ON	OFF	OFF
Direct-current part overvoltage protection	ON	ON	OFF	OFF
Overload protection	OFF	OFF	ON	OFF
FCL protection operation	OFF	OFF	ON	OFF
Overtorque protection	OFF	OFF	ON	OFF
Motor overheat protection	OFF	OFF	ON	OFF
Current sensor abnormality	ON	OFF	ON	OFF
Open phase	ON	OFF	ON	OFF
Startup stall protection	OFF	ON	ON	OFF
Overspeed protection	ON	ON	ON	OFF
[V/f] Overfrequency protection	ON	ON	ON	OFF
Speed control error	ON	ON	ON	OFF
Start error without sensor	ON	ON	ON	OFF
Sensor error	ON	ON	ON	OFF
PG error	ON	ON	ON	OFF
CPU abnormality	OFF	OFF	OFF	ON
Memory abnormality	OFF	OFF	OFF	ON
Optional error	OFF	OFF	OFF	ON
Communication timeout error	ON	OFF	OFF	ON

Contents	MO1	MO2	MO3	MO4
Insufficient voltage (power failure)	OFF	ON	OFF	ON
Setting error	ON	ON	OFF	ON
External failure 1	OFF	OFF	ON	ON
External failure 2	ON	OFF	ON	ON
External failure 3	OFF	ON	ON	ON
External failure 4	ON	ON	ON	ON

- **Selecting item: 16**  
**In operation**  
 While the motor is running, output is enabled.
- **Selecting item: 18**  
**Timer 1 elapsed**  
 When cumulative operation time exceeds a value specified in the Cumulative\_operation\_timer(1) <F-04>, output is enabled.
- **Selecting item: 19**  
**Timer 2 elapsed**  
 When cumulative operation time exceeds a value specified in the Cumulative\_operation\_timer(2) <F-05>, output is enabled.
- **Selecting item: 20**  
**Second setting block selection**  
 When the second setting block is selected as the active setting block , output is enabled.
- **Selecting item: 21**  
**Cooling fan failed**  
 When the fan failure (FnF)(GnFF)(G1FF)(G2FF)(G3FF) occurs, output is enabled.
- **Selecting item: 22**  
**DB abnormal state**  
 When the dynamic brake (DB) optional unit <VFDB2009> has an abnormality, output is enabled.

### 5.3.10 Area i (setting area for internal PLC, droop control, and mechanical loss compensation)

In the area i, you can set parameters related to the internal PLC function, droop control, and functions specific to the vector mode.

#### ■ <i-00> and <i-01>

PLC function selection

Display	Contents	Setting range or selecting item	Initialized data	Unit	Driving ReWrite
i-00	PLCL_function_usage_selection	OFF: Unused ON: Used	OFF	—	×
i-01	PLCH_function_usage_selection	0: Unused 1: PLCH ON 2: PLCH ON (PLCH output is considered as frequency/speed command input)	0	—	×

#### PLCL\_function\_usage\_selection <i-00>

When using the PLCL function, select "ON." Typically, set it to "OFF."

#### PLCH\_function\_usage\_selection <i-01>

When using the PLCH function, select "1" or "2." Typically, set it to "0."

- When "1" is selected to <i-01>

Output "o00001" from the internal PLC function becomes a frequency/speed command value via the internal change rate limits (basic setting items <3.Acc1>, <4.dEc1>, and others).

When using this function with basic setting items, select "1."

- When "2" is selected to <i-01>

Output "o00001" from the internal PLC function becomes a frequency/speed command value.

To ensure that a frequency/speed command generated in the internal PLC function is not affected by the change rate limits, select "2."

For details, refer to the "VF66PCTool Operation Manual."

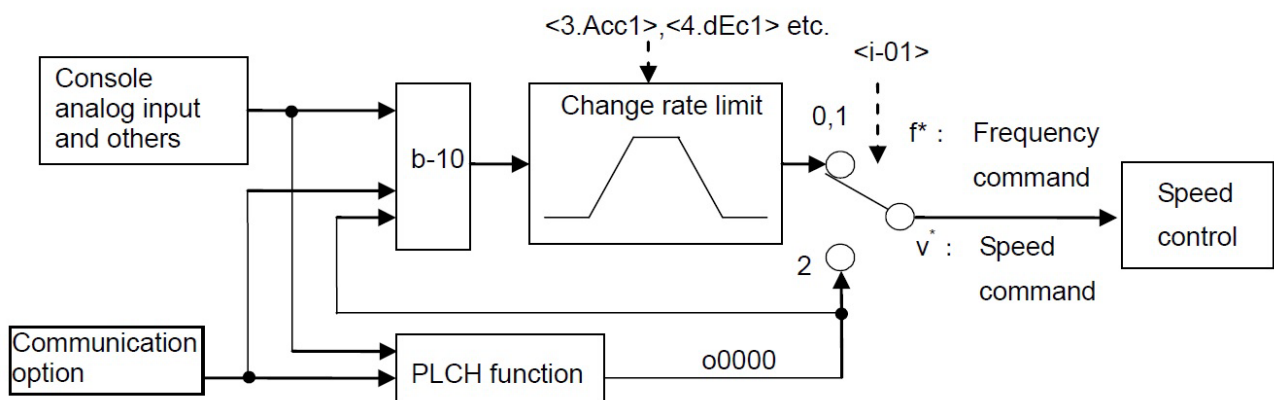

PLCH speed control selection

## ■ &lt;i-02&gt; through &lt;i-06&gt;

## Droop control setting

Display	Contents	Setting range or selecting item	Initialized data	Unit	Driving ReWrite
i-02	Droop_control_usage_selection	OFF: Unused ON: Used	OFF	—	×
i-03	Droop_start_frequency/speed	0.0 to 100.0	0.0	%	○
i-04	Droop_rate_changeover_frequency/speed	0.0 to 100.0	0.0	%	○
i-05	Droop_rate	0.0 to 50.0	0.0	%	○
i-06	Droop_start_torque	0.0 to 90.0	0.0	%	○

Set values of the Droop\_start\_frequency/speed <i-03> and the Droop\_rate\_changeover\_frequency/speed <i-04>, as a ratio to the Maximum\_frequency/speed <A-00>.

Specify each droop control. For example, these settings are used to keep a balance of torque from two motors.

**Droop\_control\_usage\_selection <i-02>**

Select whether droop control is enabled or not.

**Droop\_start\_frequency/speed <i-03>**

When frequency/speed becomes more than or equal to a value of the Droop\_start\_frequency/speed <i-03>, droop control starts.

When it becomes below a value specified in <i-03> as a result of the droop control, it is limited to the value.

**Droop\_rate\_changeover\_frequency/speed <i-04>**

When a frequency/speed command becomes more than or equal to a setting of the Droop\_rate\_changeover\_frequency/speed <i-04>, a setting of the Frequency\_command <0.FrEF>/Speed\_command <0.SrEF> becomes a standard amount of droop.

When it is lower than or equal to a setting of the Droop\_rate\_changeover\_frequency/speed <i-04>, a value specified in <i-04> becomes a standard.

When all areas are to be drooped at a rate to the Frequency\_command <0.FrEF>/Speed\_command <0.SrEF>, "0.0" should be set to the Droop\_rate\_changeover\_frequency/speed <i-04>.

Conversely, when they are to be drooped at a rate of the Maximum\_frequency/speed <A-00>, "100.0" should be set to the Droop\_rate\_changeover\_frequency/speed <i-04>.

**Droop\_rate <i-05>**

Set the amount of droop when a torque command reaches 100 %, as a ratio of droop amount to the standard frequency/speed. The standard becomes a setting of the Frequency\_command <0.FrEF>/Speed\_command <0.SrEF> when frequency/speed is more than or equal to a setting of the Droop\_rate\_changeover\_frequency/speed <i-04>, and it becomes a setting of <i-04> when frequency/speed is lower than or equal to <i-04>.

**Droop\_start\_torque <i-06>**

When torque is below a setting of <i-06>, droop control is not activated.

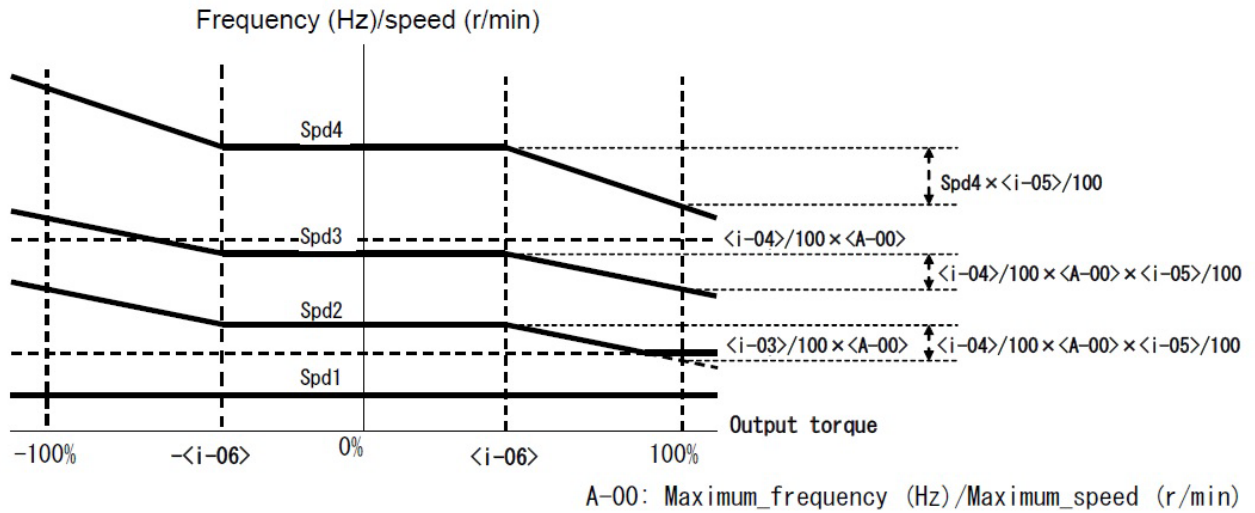

Droop control characteristics

### Droop control

[V/f] provides droop control as a simple way, but it does not assure accuracy of droop amount. When accuracy assurance of droop amount is required, [V/f] should be changed to [IM].

■ [IM] [EDM] <i-07>

[IM] [EDM] Operation mode (speed control/torque control) selection

Display	Contents	Setting range or selecting item	Initialized data	Unit	Driving ReWrite
i-07	Operation_mode_selection	0: Speed control (ASR) mode 1: Torque command is prioritized to negative direction 2: Torque command is prioritized to positive direction 3: Torque control (ATR) mode 4: Speed/torque control contact change	0	—	×

Select an operation mode (speed control/torque control/priority). These functions can be switched through external contacts in combination with multifunction input.

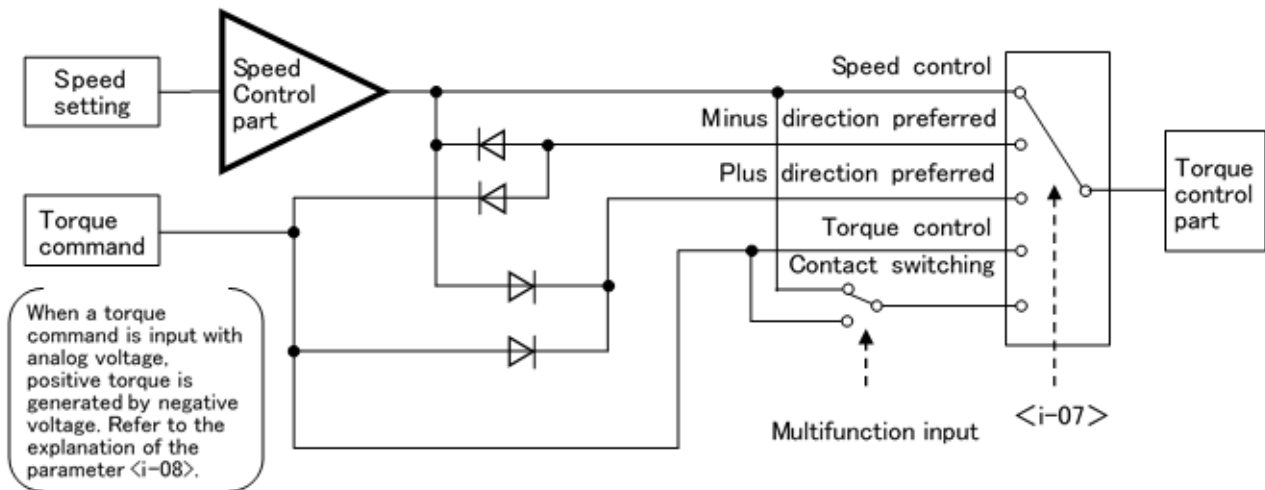

Operation mode selection

■ [IM] [EDM] <i-08>

[IM] [EDM] Torque command input place selection

Display	Contents	Setting range or selecting item	Initialized data	Unit	Driving ReWrite
i-08	Torque_command_input_place_selection	0: Analog input (1) control board <VFC66-Z> terminal [AIN1] 1: Analog input (2) <IO66-Z>, digital communication option terminal [AIN2] 2: Digital communication option 3: Internal PLC output	1	—	×

Set a torque command input place in the torque control mode.

- AIN1: Input from the terminal [AIN1] on the control board <VFC66-Z>.
- AIN2: Input from the terminal [AIN2] on <IO66-Z> and the digital communication optional board.
- Digital communication option: Input from the digital communication option.
- Internal PLC output: Torque command from the PLC. For details, refer to the "VF66PCTool Operating Manual."

When the analog input (1) and analog input (2) are selected to the Torque\_command\_input\_place\_selection, analog input characteristics should be 0 to  $\pm 10$  V.

For torque command characteristics when a torque command is input from the terminal block and the analog option, refer to the figure in the following descriptions of <i-09>.

#### ■ [IM] [EDM] <i-09>

[IM] [EDM] Analog input torque command gain

Display	Contents	Setting range or selecting item	Initialized data	Unit	Driving ReWrite
i-09	Analog_input_torque_command_gain	50.0 to 200.0	150.0	%	×

Set torque command gain to analog input. The figure to the right shows its characteristics.

When a torque command is input with analog voltage, positive torque is developed by negative voltage.

When the analog input (1) and analog input (2) are selected to the Torque\_command\_input\_place\_selection, analog input characteristics should be 0 to  $\pm 10$  V.

When "100.0" is set to the Analog\_input\_torque\_command\_gain <i-09>, input voltage of -10 V causes a torque command to reach 100 %.

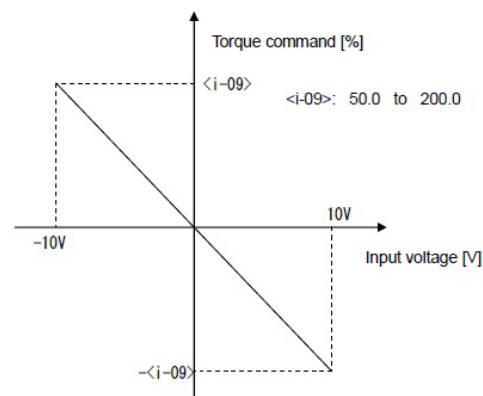

Analog input torque command gain

### ■ [IM] [EDM] <i-10> through <i-12>

#### [IM] [EDM] Changing JOG speed control gain

Display	Contents	Setting range or selecting item	Initialized data	Unit	Driving ReWrite
i-10	Speed_control_proportion_gain(2)	1 to 100	15	—	○
i-11	Speed_control_integral_time_constant(2)	20 to 10000	40	msec	○
i-12	System_inertia_moment(2)	0 to 65535	10	gm <sup>2</sup>	○

Set speed control proportion gain used for JOG operation when "1" is selected to the JOG\_proportion\_gain\_selection <i-13>.

For speed control proportion gain, refer to the speed control proportion gain setting described in {5.3.1 Basic Setting Area}.

### ■ [IM] [EDM] <i-13>

#### [IM] [EDM] JOG proportion gain selection

Display	Contents	Setting range or selecting item	Initialized data	Unit	Driving ReWrite
i-13	JOG_proportion_gain_selection	0: Use <7.ASrP> through <9.ASrJ> of the basic setting area 1: Use the Speed_control_proportion_gain(2) through System_inertia_moment(2) 2: Special mode	0	—	○

Set proportion gain, time constant, and inertia moment used for JOG operation.

- When "0" is selected to <i-13>: The setting values of the Speed\_control\_proportion\_gain(1) <7.ASrP>, Speed\_control\_integral\_time\_constant(1) <8.ASrI>, and System\_inertia\_moment(1) <9.ASrJ> are used.
- When "1" is selected to <i-13>: The setting values of <i-10> through <i-12> are used.
- When "2" is selected to <i-13>: Special mode. The setting values of <i-10> through <i-12> are used for JOG operation. The setting values of <i-10> through <i-12> are used even when a speed command is 5.56 % or less.

### ■ [IM] [EDM] <i-14> and <i-15>

[IM] [EDM] Speed control (ASR) selection

Display	Contents	Setting range or selecting item	Initialized data	Unit	Driving ReWrite
i-14	ASR_cancelation_usage_selection	OFF: Unused	ON	—	○
i-15	ASR_feed-forward_usage_selection	ON: Used			

The inverter <VF66B> has a robust speed control (MFC control) which combines feed forward with cancellation using a disturbance observer.

The cancellation and feed forward can be turned off separately. When both are turned off, a control function equal to the typical PI control will be provided. Refer to the section of the speed control proportion gain in {5.3.1 Basic Setting Area}.

### ■ [IM] [EDM] <i-16> and <i-17>

[IM] [EDM] Variable structure proportion gain adjustment

Display	Contents	Setting range or selecting item	Initialized data	Unit	Driving ReWrite
i-16	Variable_structure_proportion_gain_start_speed	0.01 to 100.00	5.00	%	○
i-17	Variable_structure_proportion_gain_minimun_gain_percentage	0 to 500	100	%	○

When "0" (S mode without Sensor) is set to the PG\_ selection <A-10>, a setting value of the Variable\_structure\_proportion\_gain\_minimun\_gain\_percentage <i-17> is 0.2 times a specified value.

Adjust variable structure proportion gain which changes proportion gain depending on a deviation between a speed command and motor speed.

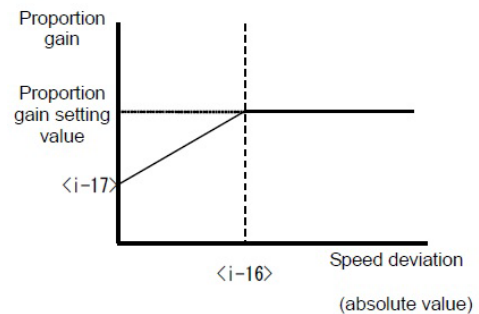

Variable structure proportion gain

### ■ [IM] <i-18>

[IM] Initial excitation mode selection (vector control with speed sensor)

Display	Contents	Setting range or selecting item	Initialized data	Unit	Driving ReWrite
i-18	Initial_excitation_selection	0: AC initial excitation 1: DC initial excitation	1	—	×

Select an initial excitation mode.

- When "0" is selected to <i-18>: For AC initial excitation, when the motor is rotated during initial excitation, the

frequency is changed to suit the motor speed to ensure that torque is not developed.

- When "1" is selected to <i-18>: For DC initial excitation, even when the motor is rotated during initial excitation, direct-current for excitation current is kept.

In the vector control without speed sensor, the AC initial excitation mode cannot be selected.

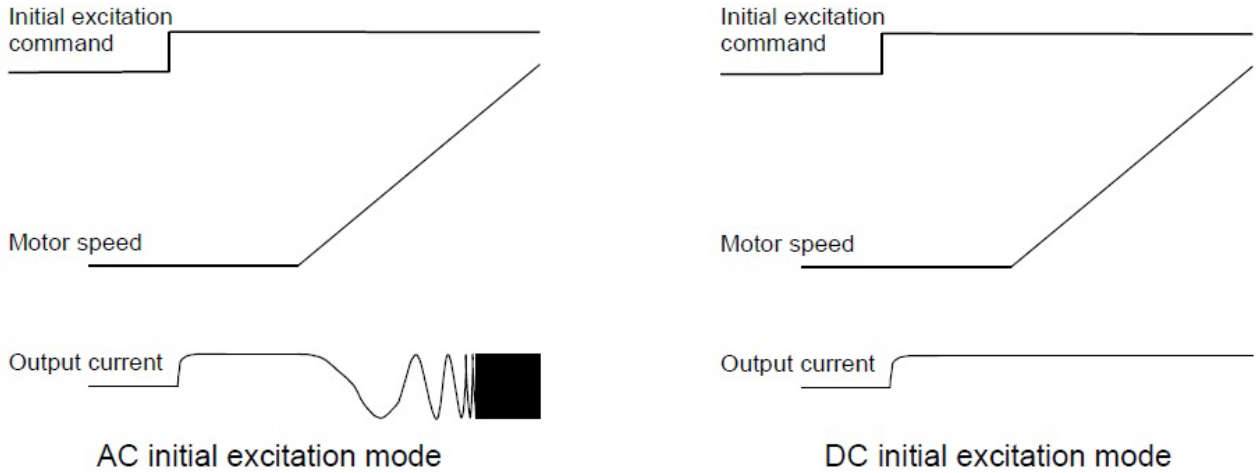

■ [IM] [EDM] <i-19> through <i-21>

For the overtorque protection (oT) and droop control, you can apply mechanical loss compensation to the torque command from which mechanical loss is subtracted.

When torque is controlled, no compensation to torque command input is provided. Also, no compensation to torque command monitor display is provided.

[IM] [EDM] Mechanical loss compensation setting

Display	Contents	Setting range or selecting item	Initialized data	Unit	Driving ReWrite
i-19	Mechanical_loss_compensation_usage_selection	OFF: Unused ON: Used	OFF	—	×
i-20	Mechanical_loss_offset_amount	0 to 100	0	%	○
i-21	Gradient_of_mechanical_loss	0 to 100	0	%	○

**Mechanical\_loss\_compensation\_usage\_selection <i-19>**

Select whether mechanical loss compensation is used or not. When it is not used, overtorque protection (oT) and droop control are performed with a value not including mechanical loss compensation.

**Mechanical\_loss\_offset\_amount <i-20>**

Set mechanical loss offset amount when speed is 0, where the rated torque shall be 100 %.

**Gradient\_of\_mechanical\_loss <i-21>**

Set a torque at the maximum speed that accounts for the motor speed proportion out of the mechanical loss.

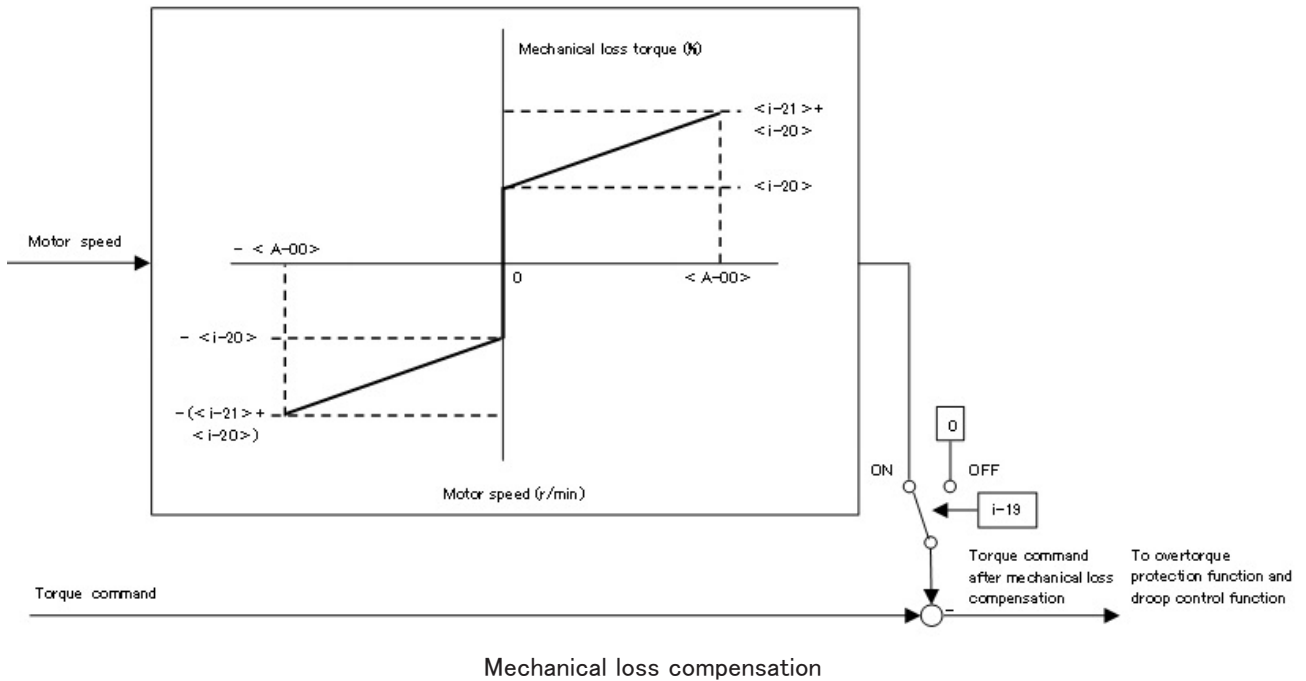

### ■ [IM] [EDM] <i-22> through <i-32>

#### [IM] [EDM] Position control setting

Display	Contents	Setting range or selecting item	Initialized data	Unit	Driving ReWrite
i-22	Positioning_speed(0)	16 to 200	100	r/min	○
i-23	Positioning_speed(1)		100	r/min	○
i-24	Positioning_acceleration_time	0.1 to 10.0	0.5	sec	○
i-25	Positioning_deceleration_time		0.5	sec	○
i-26	Creep_speed	2 to 16	2	r/min	○
i-27	Number_of_moving_pulse_within_a_creep_period	40 to 400	40	—	○
i-28	Number_of_stop_pulse	-50 to 50	0	—	○
i-29	Positioning_emergency_stop_selection	OFF: Without positioning emergency stop ON: With positioning emergency stop	OFF	—	×
i-30	Proportion_gain_for_positioning	1 to 100	15	—	○
i-31	Integral_time_constant_for_positioning	20 to 10000	40	msec	○
i-32	System_moment_of_inertia_for_positioning	0 to 65535	10	gm <sup>2</sup>	○

<i-22> through <i-32> are positioning control settings when <ASYC66-Z> is used in the special mode. Normally, do not change its Initialized data.

### 5.3.11 Area J (setting area for digital communication options)

In the area J, you can set parameters of inverter digital communication options.

■ <J-00> through <J-15>

Display	Setting item	Setting range or selecting item	Initialized data	Unit	Driving ReWrite
J-00	Digital_communica- tion_option_selection	0: OFF 1: OPCN66-Z 2: ASYC66-Z 3: DNET66-Z 4: PBUS66-Z 5: IO66-Z 6: BCD66-Z 7: CC66-Z 8: EIP66-Z	0	—	×
J-01	ASYC66-Z/ CC66-Z _option_baud_rate	ASYC66-Z 0: 1200 bps 1: 2400 bps 2: 4800 bps 3: 9600 bps 4: 19200 bps 5: 38400 bps CC66-Z 0: 156 kbps 1: 625 kbps 2: 2.5 Mbps 3: 5 Mbps 4: 10 Mbps 5: 10 Mbps	4	—	○
J-02	OPCN66-Z _option_baud_rate	0: 125 kbps 1: 250 kbps 2: 500 kbps 3: 1 Mbps 4: (For special adjustment)	3	—	×
J-03	PBUS66-Z _slave_address	0 to 126	2	—	×
J-04	OPCN66-Z_option_in- put	3 to 19	14	—	×
J-05	OPCN66-Z_option_ output	2 to 12	6	—	×
J-06	BCD66-Z_reading_ set_mode_selection	0 to 2	0	—	×

Display	Setting item	Setting range or selecting item	Initialized data	Unit	Driving ReWrite
J-07	ASYC66-Z , OPCN66-Z _transmission_selec- tion CC66-Z _CC-Link_version _number_of_occupied_ stations_selection EIP66-Z _IP_address_setting (upper_2_bytes) BCD66-Z_polarity_ signal_selection	Refer to each operation manual of ASYC66-Z , OPCN66-Z , CC66-Z , EIP66-Z , BCD66-Z.		—	×
J-08	ASYC66-Z , PBUS66-Z , CC66-Z Communication_ mode_selection EIP66-Z IP_address_ setting (lower_2_ bytes)	Refer to each operation manual of ASYC66-Z , PBUS66-Z , CC66-Z , EIP66-Z.		—	×
J-09	DNET66-Z _output_instance_ number_setting	0: Instance No.20 1: Instance No.21 2 through 10: TOYO original communication mode	0	—	×
J-10	DNET66-Z _input_instance_num- ber_setting	0: Instance No.70 1: Instance No.71 2 through 15: TOYO original communication mode	0	—	×
J-11	DNET66-Z _speed_scale_setting	-126 to 127	3	—	×
J-12	DNET66-Z _monitor_data_num- ber_setting	0 to 119	3	—	○
J-13	HighSpeed_response_ input_selection	0 to 1	0	—	×
J-14	Date/Time_data_se- lection_from_commu- nication	0: Without date/time data 1: With date/time data	0	—	×
J-15	Connected_number_ of_outside_DB (Dynamic_Brake)_ units_VFDB2009	-6 to 6	0	—	○

Display	Setting item	Setting range or selecting item	Initialized data	Unit	Driving ReWrite
J-16	EIP66-Z_subnet_mask_setting (upper_2_bytes)	For details, refer to the "instruction Manual" of <EIP66-Z>.		—	×
J-17	EIP66-Z_subnet_mask_setting (lower_2_bytes)			—	×
J-18	EIP66-Z_default_gate_way_setting (upper_2_bytes)			—	×
J-19	EIP66-Z_default_gate_way_setting (lower_2_bytes)			—	×

#### Digital\_communication\_option\_selection <J-00>

Even when this function is set to "OFF," the digital communication option can be selected for a speed command or operation command input, and multifunction input can be also used. However, optional errors are not checked.

To check optional errors, select a value supporting an installed option.

When a value other than "0" is selected without an option connected, an optional error occurs to cause the inverter to trip.

#### <J-01> through <J-08>

These settings are enabled when <ASYC66-Z>, <OPCN66-Z>, <PBUS66-Z>, <CC66-Z>, <EIP66-Z> and <BCD66-Z> are used. For details, refer to the "Instruction Manual" of each option. Normally, do not change its Initialized data.

#### <J-09> through <J-12>

These settings are enabled when <DNET66-Z> is used. For details, refer to the "Instruction Manual" of <DNET66-Z>.

#### [IM] [EDM] HighSpeed\_response\_input\_selection <J-13>

When "1" (Analog input (2) <IO66-Z>, digital communication option terminal [AIN2]) is set to the Torque\_command\_input\_place\_selection <i-08>, it is recommended that "1" be selected to the HighSpeed\_response\_input\_selection <J-13>. When "2" (Digital communication option) is set to <i-08>, it is recommended that "0" be selected to <J-13>.

With these settings, a torque command value can be input more quickly.

In [V/f], <J-13> is not used.

#### Date/Time\_data\_selection\_from\_communication <J-14>

Select whether date/time data from the digital communication option exists or not.

#### Connected\_number\_of\_outside\_DB(Dynamic\_Brake)\_units\_VFDB2009 <J-15>

Select the number of connections of <VFDB2009> as an absolute value.

When a negative value is set, if a communication with <VFDB2009> cannot be established or if it is protected, this function can stop the inverter to activate the [86A] relay.

For details, refer to the "Instruction Manual" of VFDB2009.

#### Subnet\_mask\_setting <J-16><J-17>

#### Default\_gate\_way\_setting <J-18><J-19>

These settings are enabled when <EIP66-Z> are used. For details, refer to the "Instruction Manual" of option.

### 5.3.12 Area L (setting area for input and output gain)

In the area L, you can set parameters such as analog input/output gain and offset of the inverter.

#### ■ <L-00>

Vdc detection gain setting

Display	Contents	Setting range or selecting item	Initialized data	Unit	Driving ReWrite
L-00	Vdc_detection_gain	80.0 to 120.0	100.0	%	×

#### Vdc\_detection\_gain <L-00>

This parameter indicates detection adjustment gain of direct-current voltage detected by the inverter.

By inputting voltage between the direct-current terminals [+2] and [-] during memory initialization, this Vdc detection gain is back calculated and the resulted value is set to this parameter. Normally, use it without changing the initialized value.

When the main circuit board <MAC66> or the gate board <GAC66> is replaced, an error may occur between "Vdc" display on the console and the actual voltage between direct-current terminals [+2] and [-]. In this case, to adjust direct-current voltage detection gain without initializing memory, refer to the descriptions of auto adjustment of direct-current voltage detection gain in {5.3.16 Area S}.

#### ■ <L-01> through <L-20>

Display	Setting item	Setting range or selecting item	Initialized data	Unit	Driving ReWrite
L-01	Analog_input(1)_gain	50.00 to 150.00	Adjusted	%	○
L-02	Analog_input(1)_offset	-50.00 to 50.00	Adjusted	%	○
L-03	Analog_output(1)_gain	50.0 to 150.0	Adjusted	%	○
L-04	Analog_output(1)_offset	-50.0 to 50.0	Adjusted	%	○
L-05	Analog_input(2)_gain	50.00 to 150.00	100.00	%	○
L-06	Analog_input(2)_offset	-50.00 to 50.00	0.00	%	○
L-07	Analog_input(3)_gain	50.00 to 150.00	100.00	%	○
L-08	Analog_input(3)_offset	-50.00 to 50.00	0.00	%	○
L-09	Analog_output(2)_gain	50.0 to 150.0	100.0	%	○
L-10	Analog_output(2)_offset	-50.0 to 50.0	0.0	%	○
L-11	Analog_output(3)_gain	50.0 to 150.0	100.0	%	○
L-12	Analog_output(3)_offset	-50.0 to 50.0	0.0	%	○
L-13	Analog_input(4)_gain	50.00 to 150.00	100.00	%	○
L-14	Analog_input(4)_offset	-50.00 to 50.00	0.00	%	○
L-15	Analog_input(5)_gain	50.00 to 150.00	100.00	%	○

Display	Setting item	Setting range or selecting item	Initialized data	Unit	Driving ReWrite
L-16	Analog_input(5)_offset	-50.00 to 50.00	0.00	%	○
L-17	Analog_output(4)_gain	50.0 to 150.0	100.0	%	○
L-18	Analog_output(4)_offset	-50.0 to 50.0	0.0	%	○
L-19	Analog_output(5)_gain	50.0 to 150.0	100.0	%	○
L-20	Analog_output(5)_offset	-50.0 to 50.0	0.0	%	○

<L-01> through <L-20> are setting areas for adjusting analog input/output gain and offset.

These values are automatically set by analog output adjustment and analog input adjustment of the area S. Therefore, normally you do not have to set them manually.

#### ■ <L-21>

Inverter operation mode monitor setting

Display	Contents	Setting range or selecting item	Initialized data	Unit	Driving ReWrite
L-21	Inverter_operation_mode_monitor (for read-out only)	SnPL (simple mode) FuLL (full mode)	SnPL	—	×

#### **Inverter\_operation\_mode\_monitor <L-21>**

This parameter only displays the operation mode. When the inverter operation mode is the full mode, "FuLL" is displayed.

For how to change to the "full mode," refer to {4.1.4 Changing Parameter Simple Mode and Full Mode}.

### **5.3.13 Area n (monitor adjustment area)**

In the area n, you can read out parameters of inverter capacity and mode setting.

#### ■ <n-00>

Inverter control method check

Display	Contents	Setting range or selecting item	Initialized data	Unit	Driving ReWrite
n-00	Inverter_control_mode (for read-out only)	o: V/f control V: Induction motor vector control E: ED motor vector control	o	—	×

#### **Inverter\_control\_mode <n-00>**

By reading out this setting, you can check the inverter control method.

This parameter is for read-out only. You cannot use it for writing. Writing is always prohibited.

To change the inverter control method, refer to {4.1.5 Changing Inverter Control Methods}.

## ■ &lt;n-01&gt;

Inverter capacity and voltage class check

Display	Contents	Setting range or selecting item	Initialized data	Unit	Driving ReWrite
n-01	Inverter Capacity/ Voltage_class (for read-out only)	2r222 to 18022  2r244 to 100044	Value correspond- ing to the inverter rating	—	×

**Capacity/Voltage\_class <n-01>**

By reading out this setting, you can check the inverter capacity and voltage class.

This parameter is for read-out only. You cannot use it for writing. Writing is always prohibited.

When changing the inverter capacity and voltage class specified for the control board <VFC66-Z> due to replacement of spare parts, you should first initialize memory.

For how to initialize memory, refer to {8.3 How to Initialize Inverter Main Unit}.

**5.3.14 Area o (special adjustment area)**

The area o is for special adjustment.

Setting of special adjustment analog output address and special adjustment console board output address

Display	Contents	Setting range or selecting item	Initialized data	Unit	Driving ReWrite
o-00	Special_adjustment_ analog_output_ad- dress_H	0 to 65535 (H' 0000 to H' FFFF)	—	—	○
o-01	Special_adjustment_ analog_output_ad- dress_L				
o-02	Special_adjustment_ SET66-Z_output_ad- dress_H	0 to 65535 (H' 0000 to H' FFFF)	—	—	○
o-03	Special_adjustment_ SET66-Z_output_ad- dress_L				
o-04 to o-53	—	These parameters are only for internal special adjustment. Normally, do not change its Initialized data.	—	—	—

The parameters of the area o are only for special adjustment and special applications. You cannot change them. Also, they do not appear in the seven-segment display on the console.

Each Initialized data should remain unchanged. Trying to write the data will result in an error.

### 5.3.15 Area P (setting area for internal PLC and P register)

In the area P, you can set constants of the inverter internal PLC function.

#### ■ <P-00> through <P-99>

Setting area for internal PLC and P register

Display	Contents	Setting range or selecting item	Initialized data	Unit	Driving ReWrite
P-00 to P-99	P-register_setting	Refer to the descriptions of the PLC function in another manual "VF66PCTool Operating Manual."	—	—	—

The area P is used for constants setting of the internal PLC function.

For details of the internal PLC function, refer to the "VF66PCTool Operating Manual." When the internal PLC function is not used, these settings are not required. You cannot input a value below "-20000" on the console. To input values below "-20000" for the PLC function, use <VF66 PC Tool>. For details, refer to the "VF66PCTool Operating Manual."

### 5.3.16 Area S (setting area for mode selection and analog input/output adjustment)

In the area S, you can set parameters related to special functions such as initialization, mode change, Autotuning, and data transfer as well as parameters of analog input/output gain and offset auto adjustment. To use parameters of the area S, you should input a password.

#### ■ <S-00>

##### Special mode selection

Display	Setting item	Setting range or selecting item	Initialized data	Unit	Driving ReWrite
S-00	Special_mode_selection	1: Initialize the inverter 2: Change the inverter mode 3: Clear protections 4: Switch the simple mode and full mode 10: [IM] [EDM] Full Mode Autotuning (forward) 11: [IM] [EDM] Full Mode Autotuning (reverse) 12: Direct Current Mode Autotuning (forward) 13: Direct Current Mode Autotuning (reverse) 14: [EDM] Motor D-axis Measurement Mode Autotuning (forward) 15: [EDM] Motor D-axis Measurement Mode Autotuning (reverse) 99: Initialize the inverter (for special adjustment) 101: Data transfer to <SET66EX-Z> 102: Copy data from <SET66EX-Z> (without area A) 103: Copy data from <SET66EX-Z> (with area A) 104: Compare data with <SET66EX-Z>	—	—	○

#### Special\_mode\_selection <S-00>

Setting items of <S-00> are described below.

In these items, set or change various functions of the inverter.

### ◆ Setting items of the Special\_mode\_selection <S-00>

Setting item	Descriptions
1	For details of initialization, refer to {8.3 How to Initialize Inverter Main Unit}.
2	For details of changing the inverter control method, refer to {4.1.5 Changing Inverter Control Methods}.
3	For details of clearing protections, refer to {5.4.1 How to Clear Protections}.
4	For details of switching the simple mode and full mode, refer to {4.1.4 Changing Parameter Simple Mode and Full Mode}.
10 to 15	For details of Autotuning, refer to {4.3 Autotuning of Parameters (Automatic Setting)}.
99	This is for special adjustment only. Do not use it usually.
101	For details of data transfer to <SET66EX-Z>, refer to {5.4.2 Data Transfer from/to External Console Option}.
102	For details of copying data (without area A) from <SET66EX-Z>, refer to {5.4.2 Data Transfer from/to External Console Option}.
103	For details of copying data (with area A) from <SET66EX-Z>, refer to {5.4.2 Data Transfer from/to External Console Option}.
104	For details of comparing data with <SET66EX-Z>, refer to {5.4.2 Data Transfer from/to External Console Option}.

When you input a different number from "1040" to <S-00> and press the [SET] key, "P-Err" (password error) is displayed.

### ■ <S-01> and <S-02>

Timer remaining time clear setting

Display	Contents	Setting range or selecting item	Initialized data	Unit	Driving ReWrite
S-01	Timer_remaining_time1_clear	1: Clear the Timer_remaining_time1	—	—	○
S-02	Timer_remaining_time2_clear	1: Clear the Timer_remaining_time2	—	—	○

Before clearing the timer\_remaining\_time(1)<S-01> or (2)<S-02>, enter the password "1040" into <S-01> or <S-02> respectively.

Otherwise, "P-Err" (password error) is displayed.

#### Timer\_remaining\_time1\_clear <S-01>

Before clearing the timer\_remaining\_time1<S-01>, enter the password "1040".

When "1" is set to <S-01> after entering the password "1040", a count value of the timer\_remaining\_time1 can be cleared.

#### Timer\_remaining\_time2\_clear <S-02>

Before clearing the timer\_remaining\_time2<S-02>, enter the password "1040".

When "1" is set to <S-02> after entering the password "1040", a count value of the timer\_remaining\_time2 can be cleared.

## ■ &lt;S-04&gt;

ROM rewrite switch

Display	Contents	Setting range or selecting item	Initialized data	Unit	Driving ReWrite
S-04	ROM_rewrite_switch	When "1040" is input after power-on, ROM can be rewritten.	—	—	×

**ROM\_rewrite\_switch <S-04>**

To transfer a program of the PLC function to ROM, you should specify "1040" to the ROM\_rewrite\_switch <S-04>.

For details of the PLC function, refer to the "VF66PCTool Operating Manual."

## ■ &lt;S-03&gt;, &lt;S-05&gt; through &lt;S-17&gt;

Direct-current voltage adjustment, speed control gain auto adjustment, and analog gain and offset auto adjustment

Display	Setting item	Setting range or selecting item	Initialized data	Unit	Driving ReWrite
S-03	Vdc_gain_adjustment	Direct-current voltage detection value	—	V	×
S-05	—	—	—	—	×
S-06	Analog_input(1)_adjustment	1: Offset adjustment Input a value 1000 times voltage (V): Gain adjustment	—	—	×
S-07	Analog_output(1)_adjustment	1: Offset adjustment 2: Gain adjustment	—	—	×
S-08	Analog_input(2)_adjustment	1: Offset adjustment Input a value 1000 times voltage (V): Gain adjustment	—	—	×
S-09	Analog_output(2)_adjustment	1: Offset adjustment 2: Gain adjustment	—	—	×
S-10	Analog_input(3)_adjustment	1: Offset adjustment Input a value 1000 times voltage (V): Gain adjustment	—	—	×
S-11	Analog_output(3)_adjustment	1: Offset adjustment 2: Gain adjustment	—	—	×
S-12	Analog_input(4)_adjustment	1: Offset adjustment Input a value 1000 times voltage (V): Gain adjustment	—	—	×
S-13	Analog_output(4)_adjustment	1: Offset adjustment 2: Gain adjustment	—	—	×

Display	Setting item	Setting range or selecting item	Initialized data	Unit	Driving ReWrite
S-14	Analog_input(5)_ad-justment	1: Offset adjustment Input a value 1000 times voltage (V): Gain adjustment	—	—	×
S-15	Analog_output(5)_ad-justment	1: Offset adjustment 2: Gain adjustment	—	—	×
S-16	Special adjustment	—	—	—	○
S-17	Changing_parameter_ upon_power_supply_ from_control_power_ terminal_[MR]/[MT]	By inputting "1040" after power-on, the setting parameters become changeable.	—	—	×

With the software version No.01-C5 or higher, you can change setting parameters while the power is supplied from the control power terminals [MR] and [MT], regardless of a setting of <S-17>.

Prior to software version No.01-C5, if <S-17> is not set, setting parameters cannot be changed while power is being supplied from the control power terminals [MR] and [MT].

"rtry" is displayed in the segment display.

For operating procedures listed below, refer to {5.4 Operation Using S Area Parameters}.

- How to adjust direct-current voltage with <S-03>
- How to automatically adjust analog input/output gain with <S-06> through <S-15>

## 5.4 Operation Using S Area Parameters

### 5.4.1 How to Clear Protections

To clear protections such as data displayed in the monitor item (Protection history display <trbLE>), perform the following steps on the console:

These steps can be performed even while the inverter is running.

Use "3" (Clear protections) of the Special\_mode\_selection <S-00>.

For details of the Special\_mode\_selection <S-00>, refer to {5.3.16 Area S}. For details of how to change parameter settings, refer to {4.1.3 Changing Parameter Settings}.

#### 1. When the [FNC] LED on the console turns off, press the [MONI/FNC] key.

- The [FNC] LED turns on, and a setting item appears in the seven-segment display. For example, immediately after the inverter is turned on, the first item of the basic setting area is displayed.

#### 2. Press the keys [↑] and [↓] to display "S-00."



#### 3. Press the [SET] key.

- "0" is displayed on the extreme right, and the underscore blinks on the extreme left.



#### 4. Press the [JOG/→] key to blink required digits, and then press the keys [↑] and [↓] to specify numbers to become "1040."



#### 5. Press the [SET] key.

- The password input is confirmed, and the screen returns to "S-00" display.
- When a different number from "1040" is input, "P-Err" indicating an error is displayed. In this case, press the keys [↑] and [↓] to return to "S-00." Follow the procedures again from the step 3.



Display indicating a password error

**6. Press the [SET] key.**

- Again, "0" is displayed on the extreme right, and the underscore blinks on the extreme left.

**7. Press the [JOG/→] key to blink a required digit, and then press the keys [↑] and [↓] to change the number to "3" (Clear protections).**

- The display of the setting value automatically returns to that of the setting item in ten seconds. Unless a setting value is specified while it is displayed, it cannot be changed.

**8. Press the [SET] key.**

- The display of the setting value automatically returns to that of the setting item in ten seconds. Unless the [SET] key is pressed while a setting value is displayed, it is not confirmed.
- Clear of data such as protection histories is confirmed, "CLEAR" is displayed for about 1.5 seconds, and then "S-00" is displayed again.

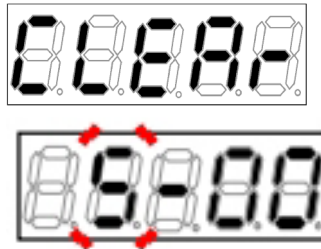
**9. Press the [MONI/FNC] key.**

- The [FNC] LED turns off, after a monitor item is displayed for about one second, its data appears.

**5.4.2 Data Transfer from/to External Console Option**

This section describes how to exchange data between the main unit and external console option <SET66EX-Z> which is connected to the inverter main unit.

### CAUTION Installation of the external console option

- Before installing <SET66EX-Z>, be sure to take any measures against static electricity. Otherwise, circuits inside the inverter may be damaged.

#### When the external console option is connected

When <SET66EX-Z> has been connected to the inverter main unit, the console on the main unit cannot be used. Also, when the main unit cannot communicate with <SET66EX-Z>, <SET66EX-Z> does not react. Check connections between them and others.

■ Transferring setting data to the external console option <SET66EX-Z>

To transfer setting data of the inverter main unit to the external console option <SET66EX-Z>, perform the following steps:

Use "101" of the Special\_mode\_selection <S-00>.

For details of the Special\_mode\_selection <S-00>, refer to {5.3.16 Area S}. For details of how to change parameter settings, refer to {4.1.3 Changing Parameter Settings}.

**1. Connect the console of the inverter main unit to <SET66EX-Z>.**

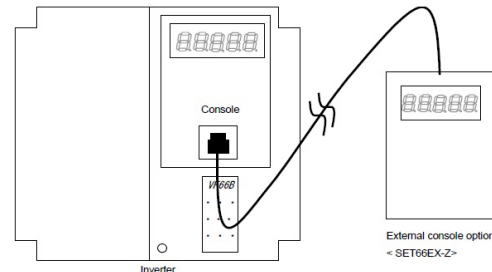

**2. When the [FNC] LED on the console turns off, press the [MONI/FNC] key.**

- The [FNC] LED turns on, and a setting item appears in the seven-segment display. For example, immediately after the inverter is turned on, the first item of the basic setting area is displayed.

**3. Press the keys [↑] and [↓] to display "S-00."**



**4. Press the [SET] key.**

- "0" is displayed on the extreme right, and the underscore blinks on the extreme left.

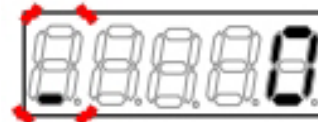

**5. Press the [JOG/→] key to blink required digits, and then press the keys [↑] and [↓] to specify numbers to become "1040."**



**6. Press the [SET] key.**

- The password input is confirmed, and the screen returns to "S-00" display.
- When a different number from "1040" is input, "P-Err" indicating an error is displayed. In this case, press the keys [↑] and [↓] to return to "S-00." Follow the procedures again from the step 4.

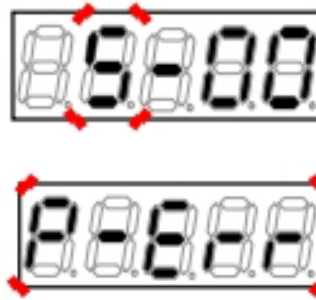

Display indicating a password error

**7. Press the [SET] key.**

- Again, "0" is displayed on the extreme right, and the underscore blinks on the extreme left.



**8. Press the [JOG/→] key to blink required digits, and then press the keys [↑] and [↓] to specify "101."**

- The display of the setting value automatically returns to that of the setting item in ten seconds. Unless a setting value is specified while it is displayed, it cannot be changed.



**9. Press the [SET] key.**

- The display of the setting value automatically returns to that of the setting item in ten seconds. Unless the [SET] key is pressed while a setting value is displayed, it is not confirmed.
- The change is confirmed, and "VtoS" and "SurE" blink alternately.

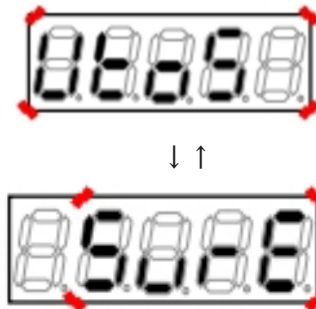

**10. Press the [SET] key.**

- The setting is confirmed, and "VtoS" is displayed.



Data is being transferred

- Data is transferred from the inverter main unit to <SET66EX-Z>. When it has been completed successfully, "End" is displayed.



Data transfer has been completed

- When communication between the main unit and <SET66EX-Z> is disconnected during transfer, transfer is interrupted.
  - (1) The inverter control method is displayed, and then it is interrupted.
  - (2) "rErr" blinks for ten seconds, then it is interrupted.



Error indication

In either case, the inverter control method is displayed after it is interrupted, and then a monitor item is displayed. Perform again the procedures from the first step.

- In a few seconds, the inverter control method is displayed, and then a monitor item is displayed.



■ Copying setting data from <SET66EX-Z> to the inverter main unit (the area A is not copied)

To transfer setting data of <SET66EX-Z> to the inverter main unit, perform the following steps:  
However, setting data of the area A is not copied.

To change an inverter model or motor model, use this way.

Use "102" of the Special\_mode\_selection <S-00>.

For details of the Special\_mode\_selection, refer to {5.3.16 Area S}. For details of how to change parameter settings, refer to {4.1.3 Changing Parameter Settings}.

### When the external console option is connected

When <SET66EX-Z> has been connected to the inverter main unit, the console on the main unit cannot be used.

Also, when the main unit cannot communicate with <SET66EX-Z>, <SET66EX-Z> does not react. Check connections between them and others.

**1. Connect the console of the inverter main unit to <SET66EX-Z>.**

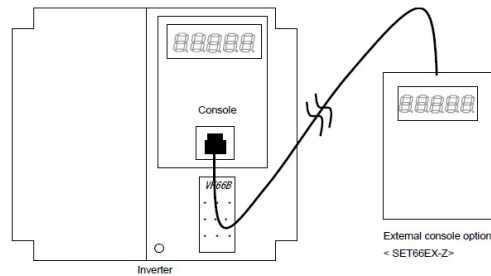

**2. When the [FNC] LED on the console turns off, press the [MONI/FNC] key.**

- The [FNC] LED turns on, and a setting item appears in the seven-segment display. For example, immediately after the inverter is turned on, the first item of the basic setting area is displayed.

**3. Press the keys [↑] and [↓] to display "S-00."**



**4. Press the [SET] key.**

- "0" is displayed on the extreme right, and the underscore blinks on the extreme left.

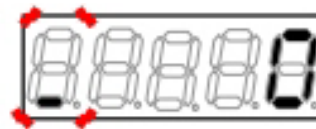

**5. Press the [JOG/→] key to blink required digits, and then press the keys [↑] and [↓] to specify numbers to become "1040."**



**6. Press the [SET] key.**

- The password input is confirmed, and the screen returns to "S-00" display.
- When a different number from "1040" is input, "P-Err" indicating an error is displayed. In this case, press the keys [↑] and [↓] to return to "S-00." Follow the procedures again from the step 4.



Display indicating a password error

**7. Press the [SET] key.**

- Again, "0" is displayed on the extreme right, and the underscore blinks on the extreme left.

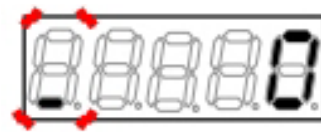
**8. Press the [JOG/→] key to blink required digits, and then press the keys [↑] and [↓] to specify "102."**

- The display of the setting value automatically returns to that of the setting item in ten seconds. Unless a setting value is specified while it is displayed, it cannot be changed.

**9. Press the [SET] key.**

- The display of the setting value automatically returns to that of the setting item in ten seconds. Unless the [SET] key is pressed while a setting value is displayed, it is not confirmed.
- The change is confirmed, and "StoV1" and "SurE" blink alternately.



↓ ↑



**10. Press the [SET] key.**

- The setting is confirmed, and "StoV1" is displayed.



Data is being transferred

- When the version of the inverter main unit is different from the software version of setting data saved in <SET66EX>, "VErr" may blink.
- Press the [STOP/RESET] key to interrupt copying data. Press the [SET] key to continue to copy data.



- Data is transferred from <SET66EX-Z> to the inverter main unit. When it has been completed successfully, "End" is displayed.
- When communication between the main unit and <SET66EX-Z> is disconnected during transfer, transfer is interrupted.
  - (1) The inverter control method is displayed, and then it is interrupted.
  - (2) "rErr" blinks for ten seconds, then it is interrupted.



Data transfer has been completed



Error indication

In either case, the inverter control method is displayed after it is interrupted, and then a monitor item is displayed. Perform again the procedures from the first step.

- Five seconds later, the inverter series name is displayed, and then contents similar to what are displayed at power-on are displayed. Refer to {4.1.2 What Are Displayed at Power-on}.



■ Copying setting data from <SET66EX-Z> (the area A is also copied)

To transfer setting data of <SET66EX-Z> to the inverter main unit, perform the following steps:  
Setting data of the area A is also copied.

When there is no change in both of the inverter model and the motor model, this way should be used.

Use "103" of the Special\_mode\_selection <S-00>.

For details of the Special\_mode\_selection, refer to {5.3.16 Area S}. For details of how to change parameter settings, refer to {4.1.3 Changing Parameter Settings}.

### When the external console option is connected

When <SET66EX-Z> has been connected to the inverter main unit, the console on the main unit cannot be used.

Also, when the main unit cannot communicate with <SET66EX-Z>, <SET66EX-Z> does not react. Check connections between them and others.

**1. Connect the console of the inverter main unit to <SET66EX-Z>.**

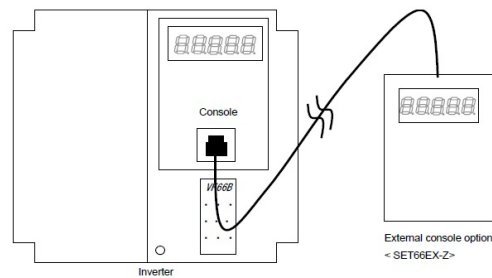

**2. When the [FNC] LED on the console turns off, press the [MONI/FNC] key.**

- The [FNC] LED turns on, and a setting item appears in the seven-segment display. For example, immediately after the inverter is turned on, the first item of the basic setting area is displayed.

**3. Press the keys [↑] and [↓] to display "S-00."**



**4. Press the [SET] key.**

- "0" is displayed on the extreme right, and the underscore blinks on the extreme left.



5. Press the [JOG/→] key to blink required digits, and then press the keys [↑] and [↓] to specify numbers to become "1040."



6. Press the [SET] key.

- The password input is confirmed, and the screen returns to "S-00" display.
- When a different number from "1040" is input, "P-Err" indicating an error is displayed. In this case, press the keys [↑] and [↓] to return to "S-00." Follow the procedures again from the step 4.



Display indicating a password error

7. Press the [SET] key.

- Again, "0" is displayed on the extreme right, and the underscore blinks on the extreme left.



8. Press the [JOG/→] key to blink required digits, and then press the keys [↑] and [↓] to specify "103."

- The display of the setting value automatically returns to that of the setting item in ten seconds. Unless a setting value is specified while it is displayed, it cannot be changed.



9. Press the [SET] key.

- The display of the setting value automatically returns to that of the setting item in ten seconds. Unless the [SET] key is pressed while a setting value is displayed, it is not confirmed.
- The change is confirmed, and "StoV2" and "SurE" blink alternately.



↓ ↑



**10. Press the [SET] key.**

- The setting is confirmed, and "StoV2" is displayed.



Data is being transferred

- When the version of the inverter main unit is different from the software version of setting data saved in <SET66EX>, "VErr" may blink.
- Press the [STOP/RESET] key to interrupt copying data. Press the [SET] key to continue to copy data.



- Data is transferred from <SET66EX-Z> to the inverter main unit. When it has been completed successfully, "End" is displayed. Setting data of the area A is also copied.
- When communication between the main unit and <SET66EX-Z> is disconnected during transfer, transfer is interrupted.



Data transfer has been completed

- (1) The inverter control method is displayed, and then it is interrupted.
- (2) "rErr" blinks for ten seconds, then it is interrupted.

In either case, the inverter control method is displayed after it is interrupted, and then a monitor item is displayed. Perform again the procedures from the first step.



Error indication

- Five seconds later, the inverter series name is displayed, and then contents similar to what are displayed at power-on are displayed. Refer to {4.1.2 What Are Displayed at Power-on}.



■ Comparing data between the inverter main unit and <SET66EX-Z>

To compare setting data between the inverter main unit and <SET66EX-Z>, perform the following steps: This function is useful when setting data of <SET66EX-Z> shall be original data of multiple inverters. Use "104" of the Special\_mode\_selection <S-00>. For details of the Special\_mode\_selection <S-00>, refer to {5.3.16 Area S}. For details of how to change parameter settings, refer to {4.1.3 Changing Parameter Settings}.

**When the external console option is connected**

When <SET66EX-Z> has been connected to the inverter main unit, the console on the main unit cannot be used. Also, when the main unit cannot communicate with <SET66EX-Z>, <SET66EX-Z> does not react. Check connections between them and others.

**1. Connect the console of the inverter main unit to <SET66EX-Z>.**

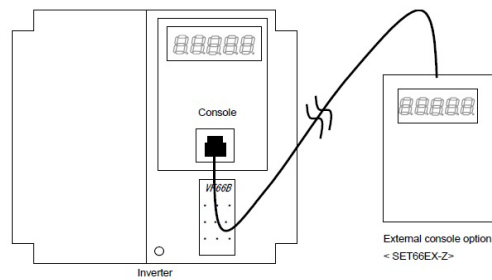

**2. When the [FNC] LED on the console turns off, press the [MONI/FNC] key.**

- The [FNC] LED turns on, and a setting item appears in the seven-segment display. For example, immediately after the inverter is turned on, the first item of the basic setting area is displayed.

**3. Press the keys [↑] and [↓] to display "S-00."**



**4. Press the [SET] key.**

- "0" is displayed on the extreme right, and the underscore blinks on the extreme left.



**5. Press the [JOG/→] key to blink required digits, and then press the keys [↑] and [↓] to specify numbers to become "1040."**



**6. Press the [SET] key.**

- The password input is confirmed, and the screen returns to "S-00" display.
- When a different number from "1040" is input, "P-Err" indicating an error is displayed. In this case, press the keys [↑] and [↓] to return to "S-00." Follow the procedures again from the step 4.



Display indicating a password error

**7. Press the [SET] key.**

- Again, "0" is displayed on the extreme right, and the underscore blinks on the extreme left.

**8. Press the [JOG/→] key to blink required digits, and then press the keys [↑] and [↓] to specify "104."**

- The display of the setting value automatically returns to that of the setting item in ten seconds. Unless a setting value is specified while it is displayed, it cannot be changed.

**9. Press the [SET] key.**

- The display of the setting value automatically returns to that of the setting item in ten seconds. Unless the [SET] key is pressed while a setting value is displayed, it is not confirmed.
- The change is confirmed, and "ComP" and "SurE" blink alternately.



↓ ↑



**10. Press the [SET] key.**

- The setting is confirmed, and "Comp" is displayed.



Data is being compared

- Compare data of the inverter main unit with that of <SET66EX-Z>.

When they match, "End" is displayed.

- When only setting data of the first setting block does not match: "CErr1" blinks.
- When only setting data of the second setting block does not match: "CErr2" blinks.
- Data of both blocks does not match: "CErrA" blinks.



- When communication between the main unit and <SET66EX-Z> is disconnected during transfer, transfer is interrupted.
  - The inverter control method is displayed, and then it is interrupted.
  - "rErr" blinks for ten seconds, then it is interrupted.

In either case, the inverter control method is displayed after it is interrupted, and then a monitor item is displayed. Perform again the procedures from the first step.



Communication error indication

- In a few seconds, the inverter control method is displayed, and then a monitor item is displayed.

**5.4.3 Direct-current Voltage Detection Gain Adjustment**

To change the Vdc\_detection\_gain <L-00> automatically, perform the following steps:

Use the Vdc\_adjustment <S-03>.

For details of the Vdc\_adjustment <S-03>, refer to {5.3.16 Area S}. For details of how to change parameter settings, refer to {4.1.3 Changing Parameter Settings}.

## **WARNING** Safety notice

- High voltage is applied to a direct-current voltage meter or a tester. Experts should measure voltage.
  - Close the front cover before turning on the power.
- It may result in a risk of electric shock.

## **CAUTION** Safety notice

- To measure direct-current voltage, use a direct-current voltage meter or a tester which can measure 500 V or more for the 200 V class inverter and 1000 V or more for the 400 V class inverter.

### Items to prepare

- Phillips screwdriver (M3)
- Phillips screwdriver (M4)
- Direct-current voltage meter or tester

### 1. Turn off the inverter.

### 2. Open the front cover.

- For how to open the front cover, refer to {3.2 How to Open and Close Front Cover}.
- Use the Phillips screwdriver (M4).

### 3. Install a direct-current voltage meter or a tester between the direct-current terminals [+2] and [-] on the main circuit terminal block of the inverter.

- For the terminal block and the position of terminals, refer to {3.3.1 How to Connect Inverter Terminals}.
- Use the Phillips screwdriver (M3).

### 4. Close the front cover and turn on the inverter.

### 5. When the [FNC] LED on the console turns off, press the [MONI/FNC] key.

- The [FNC] LED turns on, and a setting item appears in the seven-segment display. For example, immediately after the inverter is turned on, the first item of the basic setting area is displayed.

### 6. Press the keys [↑] and [↓] to display "S-00."



7. Press the [JOG/→] key to blink numbers, and then press the keys [↑] and [↓] to change them to become "S-03."



8. Press the [SET] key.

- "0" is displayed on the extreme right, and the underscore blinks on the extreme left.



9. Press the [JOG/→] key to blink required digits, and then press the keys [↑] and [↓] to specify numbers to become "1040."



10. Press the [SET] key.

- The password input is confirmed, and the screen returns to "S-03" display.
- When a different number from "1040" is input, "P-Err" indicating an error is displayed. In this case, press the keys [↑] and [↓] to return to "S-03." Follow the procedures again from the step 8.



Display indicating a password error

11. Press the [SET] key.

- Again, "0" is displayed on the extreme right, and the underscore blinks on the extreme left.



**12. Press the [JOG/→] key to blink required digits, and then press the keys [↑] and [↓] to change numbers to a value measured by the voltage meter or the tester.**

- The display of the setting value automatically returns to that of the setting item in ten seconds. Unless a setting value is specified while it is displayed, it cannot be changed.



Specify "597" if the measured value is 597 V

**13. Press the [SET] key.**

- The display of the setting value automatically returns to that of the setting item in ten seconds. Unless the [SET] key is pressed while a setting value is displayed, it is not confirmed.
- The setting of the Vdc\_detection\_gain <L-00> is automatically changed, and then "S-03" is displayed again.



**14. Press the [MONI/FNC] key.**

- The [FNC] LED turns off, after a monitor item is displayed for about one second, its data appears.



[V/f] Output frequency <Fout>



[IM] [EDM] Motor speed <SPd>

**15. Turn off the inverter, and open the front cover.**

**16. Remove the installed direct-current voltage meter or tester.**

**17. Close the front cover.**

### 5.4.4 Analog Input (1) Gain and Offset Adjustment

The sections {5.4.4} through {5.4.8} describe how to adjust analog input/output gain and offset automatically with area S parameters.

To change settings of the Analog\_input(1)\_gain <L-01> and Analog\_input(1)\_offset <L-02>, perform the following steps:

Use the Analog\_frequency/speed\_command\_characteristic\_selection <b-17> and the Analog\_input(1)\_adjustment <S-06>.

Here, use the Analog\_input(1)\_adjustment <S-06> to adjust a voltage of 0 to 10 V.

For details of the Analog\_frequency/speed\_command\_characteristic\_selection <b-17>, refer to {5.3.3 Area b}.

For details of how to change parameter settings, refer to {4.1.3 Changing Parameter Settings}.

#### Linearity of analog input command and output

When accuracy below  $\pm 0.2\%$  is required for linearity of analog input command and output, <IO66-Z> or a digital communication option should be used.



#### WARNING Short-circuit of terminals

● Be sure to turn off the inverter before short-circuiting the terminals.  
It may result in a risk of electric shock.



#### CAUTION Measuring voltage between terminals

● Great care must be taken not to touch wires and terminals when measuring voltage between terminals.  
It may result in a risk of electric shock.

Items to prepare

- Phillips screwdriver (M3)
- Phillips screwdriver (M4)
- Direct-current voltage meter or tester

1. When the [FNC] LED on the console turns off, press the [MONI/FNC] key.

- The [FNC] LED turns on, and a setting item appears in the seven-segment display. For example, immediately after the inverter is turned on, the first item of the basic setting area is displayed.

2. Press the keys [↑] and [↓] to display "b-00."



**3. Press the [JOG/→] key to blink a number, and then press the keys [↑] and [↓] to change it to become "b-17."**

- For details of the Analog\_frequency/speed\_command\_characteristic\_selection <b-17>, refer to {5.3.3 Area b}.



**4. Press the [SET] key.**

- The selection of "b-17" is confirmed, the current setting value (Initialized data is "1") is displayed.
- The display of the setting value automatically returns to that of the setting item in ten seconds. Unless a setting value is specified while it is displayed, it cannot be changed.



**5. Press the keys [↑] and [↓] to change the number to "0" (0 to ±10 V).**

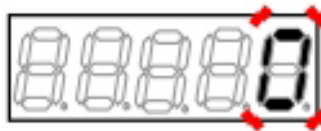

**6. Press the [SET] key.**

- The change is confirmed, and "b-17" is displayed again.
- The display of the setting value automatically returns to that of the setting item in ten seconds. Unless the [SET] key is pressed while a setting value is displayed, the change cannot be confirmed.



**7. Turn off the inverter.**

**8. Open the front cover.**

- For how to open the front cover, refer to {3.2 How to Open and Close Front Cover}.
- Use the Phillips screwdriver (M4).

**9. Short circuit the terminals [AIN1] and [GND] on the control board <VFC66-Z>.**

- For the terminal block and the position of terminals, refer to {3.3.1 How to Connect Inverter Terminals}.
- Use the Phillips screwdriver (M3).

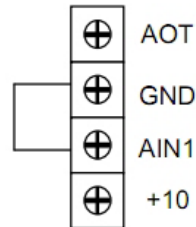

**10. Close the front cover and turn on the inverter.**

**11. Press the [MONI/FNC] key.**

- The [FNC] LED turns on, and a setting item appears in the seven-segment display. For example, immediately after the inverter is turned on, the first item of the basic setting area is displayed.

**12. Press the keys [↑] and [↓] to display "S-00."**



**13. Press the [JOG/→] key to blink numbers, and then press the keys [↑] and [↓] to change them to become "S-06."**

- For details of the Analog\_input(1)\_adjustment < S-06>, refer to {5.3.16 Area S}.



**14. Press the [SET] key.**

- "0" is displayed on the extreme right, and the underscore blinks on the extreme left.



15. Press the [JOG/→] key to blink required digits, and then press the keys [↑] and [↓] to specify numbers to become "1040."



16. Press the [SET] key.

- The password input is confirmed, and the screen returns to "S-06" display.
- When a different number from "1040" is input, "P-Err" indicating an error is displayed. In this case, press the keys [↑] and [↓] to return to "S-06." Follow the procedures again from the step 14.



Display indicating a password error

17. Press the [SET] key.

- Again, "0" is displayed on the extreme right, and the underscore blinks on the extreme left.



18. Press the [JOG/→] key to blink required digits, and then press the keys [↑] and [↓] to specify "1."

- The display of the setting value automatically returns to that of the setting item in ten seconds. Unless a setting value is specified while it is displayed, it cannot be changed.



19. Press the [SET] key.

- The change is confirmed, and "S-06" is displayed again.
- The display of the setting value automatically returns to that of the setting item in ten seconds. Unless the [SET] key is pressed while a setting value is displayed, it is not confirmed.



20. Turn off the inverter, and open the front cover.

21. Remove the short-circuit wire between the terminals [AIN1] and [GND].

22. Short circuit the terminals [AIN1] and [+10].

23. Install the direct-current voltage meter or tester between the terminals [AIN1] and [GND].

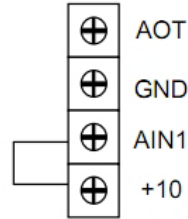

24. Close the front cover and turn on the inverter.

25. Press the [MONI/FNC] key.

- The [FNC] LED turns on, and the first setting item of the basic setting area is displayed.

26. Press the keys [↑] and [↓] to display "S-00."



27. Press the [JOG/→] key to blink numbers, and then press the keys [↑] and [↓] to change them to become "S-06."



28. Press the [SET] key.

- "0" is displayed on the extreme right, and the underscore blinks on the extreme left.



29. Press the [JOG/→] key to blink required digits, and then press the keys [↑] and [↓] to specify numbers to become "1040."



**30. Press the [SET] key.**

- The password input is confirmed, and the screen returns to "S-06" display.
- When a different number from "1040" is input, "P-Err" indicating an error is displayed. In this case, press the keys [↑] and [↓] to return to "S-06." Follow the procedures again from the step 28.



Display indicating a password error

**31. Press the [SET] key.**

- Again, "0" is displayed on the extreme right, and the underscore blinks on the extreme left.

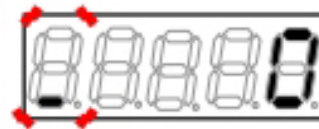
**32. Press the [JOG/→] key to blink required digits, and then press the keys [↑] and [↓] to specify a value 1000 times a value measured by the voltage meter or the tester.**

- Inputting a value 1000 times a voltage value of the analog input (1) enables gain adjustment of the analog input (1).
- When you cannot measure the voltage, specify "9930." In this case, however, accuracy will be decreased.



Specify "9983" if the measured value is 9.983 V

**33. Press the [SET] key.**

- When "S-06" is displayed again, the settings of the Analog\_input(1)\_gain <L-01> and Analog\_input(1)\_offset <L-02> are automatically changed.

**34. Press the [MONI/FNC] key.**

- The [FNC] LED turns off, after a monitor item is displayed for about one second, its data appears.

**35. Turn off the inverter, and open the front cover.****36. Remove the short-circuit wire between the terminals [AIN1] and [+10].****37. Remove the installed direct-current voltage meter or tester.****38. Close the front cover.**

### 5.4.5 Analog Input (1) Gain Adjustment (for 4 to 20 mA input characteristics)

The sections {5.4.4} through {5.4.8} describe how to adjust analog input/output gain and offset automatically with area S parameters.

For 4 to 20 mA input characteristics, perform the following steps to adjust a setting of the Analog\_input(1)\_gain <L-01>:

Be sure to do this after adjusting a voltage of 0 to 10 V in the Analog\_input(1)\_gain <L-01> and Analog\_input(1)\_offset <L-02>.

Use the Analog\_frequency/speed\_command\_characteristic\_selection <b-17> and the Analog\_input(1)\_gain <L-01>.

For details of the Analog\_frequency/speed\_command\_characteristic\_selection <b-17>, refer to {5.3.3 Area b}.

For details of the Analog\_input(1)\_gain <L-01>, refer to {5.3.12 Area L}. For details of how to change parameter settings, refer to {4.1.3 Changing Parameter Settings}.



## WARNING

Installation of current power supply

- Be sure to turn off the inverter before installing the current power supply.

It may result in a risk of electric shock.

- Be sure to turn off the inverter before changing the switch.

It may result in a risk of electric shock.

Items to prepare

- Phillips screwdriver (M3)
- Phillips screwdriver (M4)
- Current power supply

**1. When the [FNC] LED on the console turns off, press the [MONI/FNC] key.**

- The [FNC] LED turns on, and a setting item appears in the seven-segment display. For example, immediately after the inverter is turned on, the first item of the basic setting area is displayed.

**2. Press the keys [↑] and [↓] to display "b-00."**



**3. Press the [JOG/→] key to blink a number, and then press the keys [↑] and [↓] to change it to become "b-17."**

- For details of the Analog\_frequency/speed\_command\_characteristic\_selection <b-17>, refer to {5.3.3 Area b}.



**4. Press the [SET] key.**

- The selection of "b-17" is confirmed, the current setting value (Initialized data is "1") is displayed.
- The display of the setting value automatically returns to that of the setting item in ten seconds. Unless a setting value is specified while it is displayed, it cannot be changed.

**5. Press the keys [↑] and [↓] to change the number to "2" (4 to 20 mA).****6. Press the [SET] key.**

- The change is confirmed, and "b-17" is displayed again.
- The display of the setting value automatically returns to that of the setting item in ten seconds. Unless the [SET] key is pressed while a setting value is displayed, the change cannot be confirmed.

**7. Turn off the inverter.****8. Open the front cover.**

- For how to open the front cover, refer to {3.2 How to Open and Close Front Cover}.
- Use the Phillips screwdriver (M4).

**9. Connect the current power supply between the terminals [AIN1] and [GND] on the control board < VFC66-Z>.**

- For the terminal block and the position of terminals, refer to {3.3.1 How to Connect Inverter Terminals}.
- Use the Phillips screwdriver (M3).

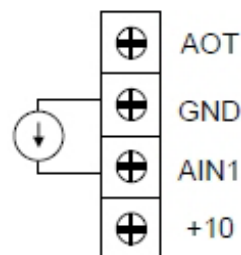

10. Move the position of the switch [SW1] to "ON" (terminal block side) using the tip of a pair of tweezers or a tool with a narrow tip (about 0.8 mm).

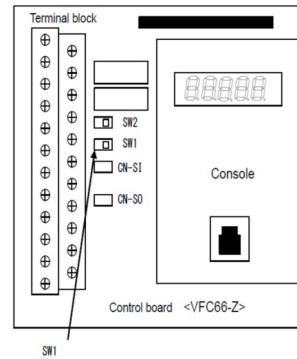

11. Close the front cover and turn on the inverter.

- The same display as that of power-on appears on the console, and then it enters the monitor (MONI) mode.

12. Now, data of a monitor item is displayed. Press either of the [SET] key, [↑] key, or [↓] key to return to the display of the monitor item.

- In the monitor (MONI) mode, a monitor item is displayed for one second, and then its data is displayed.
- For details of the monitor (MONI) mode, refer to {4.1.6 Checking Operating State}. For details of monitor items, refer to {4.1.7 List of Monitor Items}.

13. Press either of the [SET] key, [↑] key, or [↓] key to display "Vin" (Analog input voltage).

- Unless you press any key within one second while the monitor item is displayed, you cannot change it.



14. Turn on the current power supply, and input a current of 20 mA to the terminal [AIN1].

- In the seven-segment display on the console, a voltage value of the terminal [AIN1] is displayed as data of "Vin."
- Items displayed as "Vin" can be changed with a setting of the Analog\_input\_monitor\_display\_selection <G-16>.



Setting "1" displays Value from the analog input (1) terminal [AIN1].

15. Press the [MONI/FNC] key.

- The [FNC] LED turns on, the console enters the function (FNC) mode, and then a setting item appears in the seven-segment display. For example, immediately after the inverter is turned on, the first item of the basic setting area is displayed.

16. Press the keys [↑] and [↓] to display "L-00."



**17. Press the [JOG/→] key to blink numbers, and then press the keys [↑] and [↓] to change them to become "L-01."**

- For details of the Analog\_input(1)\_gain <L-01>, refer to {5.3.12 Area L}.



**18. Press the [SET] key.**

- The current setting value of <L-01> is displayed. Its Initialized data is "100.0."
- The display of the setting value automatically returns to that of the setting item in ten seconds. Unless a setting value is specified while it is displayed, it cannot be changed.



**19. Press the [JOG/→] key to blink required digits, and then press the keys [↑] and [↓] to change numbers.**

- When a numerical value of "Vin" is smaller than "10.00," set a larger value to "L-01."
- When a numerical value of "Vin" is larger than "10.00," set a smaller value to "L-01."

**20. Press the [SET] key.**

- The change is confirmed, and "L-01" is displayed again.
- The display of the setting value automatically returns to that of the setting item in ten seconds. Unless the [SET] key is pressed while a setting value is displayed, the change cannot be confirmed.



**21. Press the [MONI/FNC] key.**

- "Vin" (Analog input voltage) is displayed.
- About one second later, it automatically changes to the data display and a voltage value of the terminal [AIN1] is displayed.

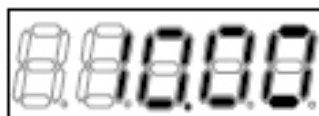

**22. When a numerical value of "Vin" is not "10.00," press the [MONI/FNC] key.**

- "L-01" is displayed.



**23. Repeat the steps 18 through 22 to adjust a value of <L-01> to ensure that a numerical value of "Vin" becomes "10.00."**

- Every time the [MONI/FNC] key is pressed, the setting item "L-01" and the monitor item "Vin" are displayed alternately.

**24. Turn off the inverter, and open the front cover.**

**25. Remove the installed current power supply.**

**26. Close the front cover.**

### 5.4.6 Analog Output (1) Gain and Offset Adjustment

The sections {5.4.4} through {5.4.8} describe how to adjust analog input/output gain and offset automatically with area S parameters.

To change settings of the Analog\_output(1)\_gain <L-03> and Analog\_output(1)\_offset <L-04>, perform the following steps:

Be sure to do this after adjusting offset and gain of the analog input (1).

Use the Analog\_frequency/speed\_command\_characteristic\_selection <b-17>, Analog\_output(1)\_characteristics\_selection <b-21>, and Analog\_output(1)\_adjustment <S-07>.

For details of the Analog\_frequency/speed\_command\_characteristic\_selection <b-17>, refer to {5.3.3 Area b}. For details of the Analog\_output(1)\_adjustment <S-07>, refer to {5.3.16 Area S}. For details of how to change parameter settings, refer to {4.1.3 Changing Parameter Settings}.



## WARNING Short-circuit of terminals

● Be sure to turn off the inverter before short-circuiting the terminals.

It may result in a risk of electric shock.

Items to prepare

- Phillips screwdriver (M3)
- Phillips screwdriver (M4)

#### 1. Turn off the inverter.

#### 2. Open the front cover.

- For how to open the front cover, refer to {3.2 How to Open and Close Front Cover}.
- Use the Phillips screwdriver (M4).

#### 3. Short circuit the terminals [AOT1] and [AIN1] on the control board <VFC66-Z>.

- For the terminal block and the position of terminals, refer to {3.3.1 How to Connect Inverter Terminals}.
- Use the Phillips screwdriver (M3).

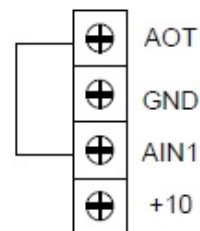

**4. Close the front cover and turn on the inverter.****5. Press the [MONI/FNC] key.**

- The [FNC] LED turns on, and a setting item appears in the seven-segment display. For example, immediately after the inverter is turned on, the first item of the basic setting area is displayed.

**6. Press the keys [↑] and [↓] to display "b-00."****7. Press the [JOG/→] key to blink numbers, and then press the keys [↑] and [↓] to change them to become "b-17."**

- For details of the Analog\_frequency/speed\_command\_characteristic\_selection <b-17>, refer to {5.3.3 Area b}.

**8. Press the [SET] key.**

- The selection of "b-17" is confirmed, the current setting value (Initialized data is "1") is displayed.
- The display of the setting value automatically returns to that of the setting item in ten seconds. Unless a setting value is specified while it is displayed, it cannot be changed.

**9. Press the keys [↑] and [↓] to change the number to "0" (0 to ±10 V).****10. Press the [SET] key.**

- The change is confirmed, and "b-17" is displayed again.
- The display of the setting value automatically returns to that of the setting item in ten seconds. Unless the [SET] key is pressed while a setting value is displayed, the change cannot be confirmed.



11. Press the [JOG/→] key to blink numbers, and then press the keys [↑] and [↓] to change them to become "b-21."

- For details of the Analog\_output(1)\_characteristics\_selection <b-21>, refer to {5.3.3 Area b}.



12. Press the [SET] key.

- The selection of "b-21" is confirmed, the current setting value (Initialized data is "1") is displayed.



13. Press the keys [↑] and [↓] to change the number to "0" (Output voltage).

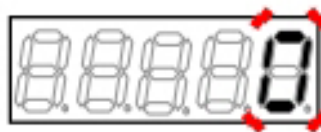

14. Press the [SET] key.

- The change is confirmed, and "b-21" is displayed again.



15. Press the [JOG/→], [↑], and [↓] keys to specify "S-07."

- For details of the Analog\_output(1)\_adjustment <S-07>, refer to {5.3.16 Area S}.



16. Press the [SET] key.

- "0" is displayed on the extreme right, and the underscore blinks on the extreme left.



17. Press the [JOG/→] key to blink required digits, and then press the keys [↑] and [↓] to specify numbers to become "1040."



18. Press the [SET] key.

- The password input is confirmed, and the screen returns to "S-07" display.
- When a different number from "1040" is input, "P-Err" indicating an error is displayed. In this case, press the keys [↑] and [↓] to return to "S-07." Follow the procedures again from the step 16.



Display indicating a password error

19. Press the [SET] key.

- Again, "0" is displayed on the extreme right, and the underscore blinks on the extreme left.



20. Press the [JOG/→] key to blink a required digit, and then press the keys [↑] and [↓] to change the number to "1" (Analog output(1) offset adjustment).

- The display of the setting value automatically returns to that of the setting item in ten seconds. Unless a setting value is specified while it is displayed, it cannot be changed.



21. Press the [SET] key.

- The change is confirmed, and "S-07" is displayed again.
- The display of the setting value automatically returns to that of the setting item in ten seconds. Unless the [SET] key is pressed while a setting value is displayed, it is not confirmed.



22. Press the [JOG/→] key to blink a number, and then press the keys [↑] and [↓] to change it to become "b-21."



23. Press the [SET] key.

- The selection of "b-21" is confirmed, "0" is displayed as a current setting value.



24. Press the keys [↑] and [↓] to change the number to "6" (Calibration).



25. Press the [SET] key.

- The change is confirmed, and "b-21" is displayed again.



26. Press the [JOG/→], [↑], and [↓] keys to specify "S-07."



27. Press the [SET] key.

- "0" is displayed on the extreme right, and the underscore blinks on the extreme left.



28. Press the [JOG/→] key to blink required digits, and then press the keys [↑] and [↓] to specify numbers to become "1040."



29. Press the [SET] key.

- The password input is confirmed, and the screen returns to "S-07" display.
- When a different number from "1040" is input, "P-Err" indicating an error is displayed. In this case, press the keys [↑] and [↓] to return to "S-07." Follow the procedures again from the step 27.



Display indicating a password error

30. Press the [SET] key.

- Again, "0" is displayed on the extreme right, and the underscore blinks on the extreme left.



31. Press the [JOG/→] key to blink a required digit, and then press the keys [↑] and [↓] to change the number to "2" (Analog output(1) gain adjustment).

- The display of the setting value automatically returns to that of the setting item in ten seconds. Unless a setting value is specified while it is displayed, it cannot be changed.



**32. Press the [SET] key.**

- The display of the setting value automatically returns to that of the setting item in ten seconds. Unless the [SET] key is pressed while a setting value is displayed, it is not confirmed.
- When "S-07" is displayed again, the settings of the Analog\_output(1)\_gain <L-03> and Analog\_output(1)\_offset <L-04> are automatically changed.

**33. Press the [MONI/FNC] key.**

- The [FNC] LED turns off, after a monitor item is displayed for about one second, its data appears.

**34. Turn off the inverter, and open the front cover.****35. Remove the short-circuit wire between the terminals [AOT1] and [AIN1].****36. Close the front cover.**

### 5.4.7 Analog Input (2) through (5) Gain and Offset Adjustment

The sections {5.4.4} through {5.4.8} describe how to adjust analog input/output gain and offset automatically with area S parameters.

#### Analog input (2) through (5) adjustment

Analog input (2) through (5) require <IO66-Z> and the digital communication option.

When these optional boards are not used, the settings and adjustment described below are not required.

This section describes the procedures for changing analog input (2) through (5) gain and analog input (2) through (5) offset, with the following example of the Analog\_input(2)\_gain <L-05> and Analog\_input(2)\_offset <L-06> when <IO66-Z> is used.

Be sure to do this after adjusting offset and gain of the analog input (1).

Use the Analog\_input(2)\_characteristics\_selection <G-03> and the Analog\_input(2)\_adjustment <S-08>.

For details of the Analog\_input(2)\_characteristics\_selection <G-03>, refer to {5.3.8 Area G}. For details of the Analog\_input(2)\_adjustment <S-08>, refer to {5.3.16 Area S}. For details of how to change parameter settings, refer to {4.1.3 Changing Parameter Settings}.

#### Analog input (3) through (5) gain and offset adjustment

For analog input (3) through (5) gain and offset, refer to the area L.

Specify setting items of the area G and area S to meet analog input (3) through (5) gain and offset. Then, follow the procedures below.



#### **WARNING** Short-circuit of terminals

● Be sure to turn off the inverter before short-circuiting the terminals.

It may result in a risk of electric shock.



#### **CAUTION** Measuring voltage between terminals

● Great care must be taken not to touch electrical wires and terminals when measuring voltage between terminals.

It may result in a risk of electric shock.

Items to prepare

- Phillips screwdriver (M3)
- Phillips screwdriver (M4)
- Direct-current voltage meter or tester

**1. When the [FNC] LED on the console turns off, press the [MONI/FNC] key.**

- The [FNC] LED turns on, and a setting item appears in the seven-segment display. For example, immediately after the inverter is turned on, the first item of the basic setting area is displayed.

2. Press the keys [↑] and [↓] to display "G-00."



3. Press the [JOG/→] key to blink numbers, and then press the keys [↑] and [↓] to change them to become "G-03."

- For details of the Analog\_input(2)\_characteristics\_selection <G-03>, refer to {5.3.8 Area G}.



4. Press the [SET] key.

- The selection of "G-03" is confirmed, the current setting value (Initialized data is "1") is displayed.
- The display of the setting value automatically returns to that of the setting item in ten seconds. Unless a setting value is specified while it is displayed, it cannot be changed.



5. Press the keys [↑] and [↓] to change the number to "0" (0 to ±10 V).



6. Press the [SET] key.

- The change is confirmed, and "G-03" is displayed again.
- The display of the setting value automatically returns to that of the setting item in ten seconds. Unless the [SET] key is pressed while a setting value is displayed, the change cannot be confirmed.



**7. Turn off the inverter.**

**8. Open the front cover.**

- For how to open the front cover, refer to {3.2 How to Open and Close Front Cover}.
- Use the Phillips screwdriver (M4).

**9. Short circuit the terminals [AIN2], [G], and [G-IN] on the terminal block of <IO66-Z>.**

- For the terminal block and the position of terminals, refer to {3.3.1 How to Connect Inverter Terminals}.
- Use the Phillips screwdriver (M3).

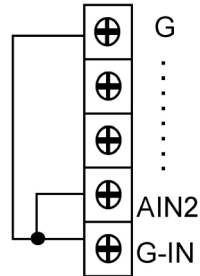

**10. Close the front cover and turn on the inverter.**

**11. Press the [MONI/FNC] key.**

- The [FNC] LED turns on, and a setting item appears in the seven-segment display. For example, immediately after the inverter is turned on, the first item of the basic setting area is displayed.

**12. Press the keys [↑] and [↓] to display "S-00."**



**13. Press the [JOG/→] key to blink numbers, and then press the keys [↑] and [↓] to change them to become "S-08."**

- For details of the Analog\_input(2)\_adjustment < S-08>, refer to {5.3.16 Area S}.



**14. Press the [SET] key.**

- "0" is displayed on the extreme right, and the underscore blinks on the extreme left.



**15. Press the [JOG/→] key to blink required digits, and then press the keys [↑] and [↓] to specify numbers to become "1040."**

**16. Press the [SET] key.**

- The password input is confirmed, and the screen returns to "S-08" display.
- When a different number from "1040" is input, "P-Err" indicating an error is displayed. In this case, press the keys [↑] and [↓] to return to "S-08." Follow the procedures again from the step 14.



Display indicating a password error

**17. Press the [SET] key.**

- Again, "0" is displayed on the extreme right, and the underscore blinks on the extreme left.

**18. Press the [JOG/→] key to blink required digits, and then press the keys [↑] and [↓] to specify "1."**

- The display of the setting value automatically returns to that of the setting item in ten seconds. Unless a setting value is specified while it is displayed, it cannot be changed.

**19. Press the [SET] key.**

- The change is confirmed, and "S-08" is displayed again.
- The display of the setting value automatically returns to that of the setting item in ten seconds. Unless the [SET] key is pressed while a setting value is displayed, it is not confirmed.



20. Turn off the inverter, and open the front cover.

21. Remove the short-circuit wire between the terminals [AIN2] and [GND] on <IO66-Z>.

22. Short circuit the terminal [AIN2] and the terminal [+10] on the control board <VFC66-Z>.

- Keep the terminals [G] and [G-IN] on <IO66-Z> short-circuited.

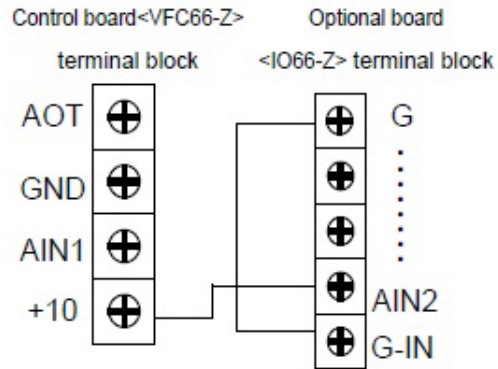

23. Install a direct-current voltage meter or a tester between the terminals [AIN2] and [GND].

24. Close the front cover and turn on the inverter.

25. Press the [MONI/FNC] key.

- The [FNC] LED turns on, and the first setting item of the basic setting area is displayed.

26. Press the keys [↑] and [↓] to display "S-00."



27. Press the [JOG/→] key to blink numbers, and then press the keys [↑] and [↓] to change them to become "S-08."



28. Press the [SET] key.

- "0" is displayed on the extreme right, and the underscore blinks on the extreme left.



29. Press the [JOG/→] key to blink required digits, and then press the keys [↑] and [↓] to specify numbers to become "1040."



**30. Press the [SET] key.**

- The password input is confirmed, and the screen returns to "S-08" display.
- When a different number from "1040" is input, "P-Err" indicating an error is displayed. In this case, press the keys [↑] and [↓] to return to "S-08." Follow the procedures again from the step 28.

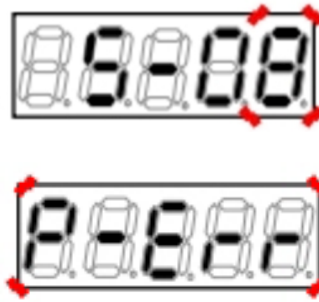

Display indicating a password error

**31. Press the [SET] key.**

- Again, "0" is displayed on the extreme right, and the underscore blinks on the extreme left.

**32. Press the [JOG/→] key to blink required digits, and then press the keys [↑] and [↓] to specify a value 1000 times a value measured by the voltage meter or the tester.**

- Inputting a value 1000 times a voltage value of the analog input (2) enables gain adjustment of the analog input (2).
- When you cannot measure the voltage, specify "9930." In this case, however, accuracy will be decreased.



Specify "9983" if the measured value is 9.983 V

**33. Press the [SET] key.**

- When "S-08" is displayed again, the settings of the Analog\_input(2)\_gain <L-05> and Analog\_input(2)\_offset <L-06> are automatically changed.

**34. Press the [MONI/FNC] key.**

- The [FNC] LED turns off, after a monitor item is displayed for about one second, its data appears.

35. Turn off the inverter, and open the front cover.
36. Remove the wire between the terminal [AIN2] on <IO66-Z> and the terminal [+10] on the control board <VFC66-Z>, and the wire between the terminals [G] and [G-IN] on <IO66-Z>.
37. Remove the installed direct-current voltage meter or tester.
38. Close the front cover.

### 5.4.8 Analog Output (2) through (5) Gain and Offset Adjustment

The sections {5.4.4} through {5.4.8} describe how to adjust analog input/output gain and offset automatically with area S parameters.

#### Analog output (2) through (5) adjustment

Analog output (2) through (5) require <IO66-Z> and the digital communication option.

When these optional boards are not used, the settings and adjustment described below are not required.

This section describes the procedures for changing analog output (2) through (5) gain and analog output (2) through (5) offset, with the following example of the Analog\_output(2)\_gain <L-09> and Analog\_output(2)\_offset <L-10> when <IO66-Z> is used.

Be sure to do this after adjusting offset and gain of the analog input (1).

Use the Analog\_output(2)\_characteristics\_selection <G-09> and the Analog\_output(2)\_adjustment <S-09>. For details of analog frequency/speed command characteristics selection, refer to {5.3.3 Area b}. For details of the analog output (2) characteristics selection, refer to {5.3.8 Area G}. For details of the analog output (2) adjustment, refer to {5.3.16 Area S}. For details of how to change parameter settings, refer to {4.1.3 Changing Parameter Settings}.

#### Analog output (3) through (5) gain and offset adjustment

For analog output (3) through (5) gain and offset, refer to the area L.

Specify setting items of the area G and area S to meet analog output (3) through (5) gain and offset. Then, follow the procedures below.



### **WARNING** Short-circuit of terminals

● Be sure to turn off the inverter before short-circuiting the terminals.

It may result in a risk of electric shock.

Items to prepare

- Phillips screwdriver (M3)
- Phillips screwdriver (M4)

#### 1. Turn off the inverter, and open the front cover.

- For how to open the front cover, refer to {3.2 How to Open and Close Front Cover}.
- Use the Phillips screwdriver (M4).

**2. Short circuit the terminal [AOT2] on <IO66-Z> and the terminal [AIN1] on the control board <VFC66-Z>.**

- Use the Phillips screwdriver (M3).

**3. Short circuit the terminals [G] and [G-OT] on <IO66-Z>.**

- Use the Phillips screwdriver (M3).

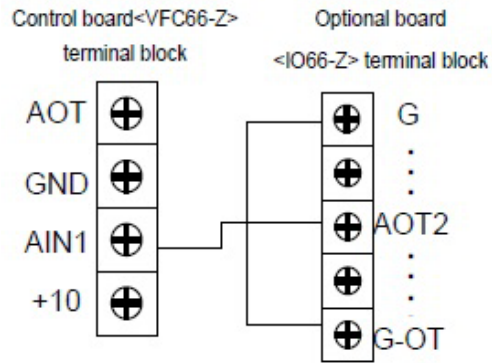

**4. Close the front cover and turn on the inverter.**

**5. Press the [MONI/FNC] key.**

- The [FNC] LED turns on, and a setting item appears in the seven-segment display. For example, immediately after the inverter is turned on, the first item of the basic setting area is displayed.

**6. Press the keys [↑] and [↓] to display "b-00."**



**7. Press the [JOG/→] key to blink a number, and then press the keys [↑] and [↓] to change it to become "b-17."**

- For details of the Analog\_frequency/speed\_command\_characteristic\_selection <b-17>, refer to {5.3.3 Area b}.



**8. Press the [SET] key.**

- The selection of "b-17" is confirmed, the current setting value (Initialized data is "1") is displayed.
- The display of the setting value automatically returns to that of the setting item in ten seconds. Unless a setting value is specified while it is displayed, it cannot be changed.

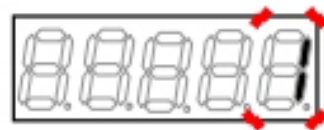

9. Press the keys [↑] and [↓] to change the number to "0" (0 to ±10 V).



10. Press the [SET] key.

- The change is confirmed, and "b-17" is displayed again.
- The display of the setting value automatically returns to that of the setting item in ten seconds. Unless the [SET] key is pressed while a setting value is displayed, the change cannot be confirmed.



11. Press the [JOG/→], [↑], and [↓] keys to specify "G-09."

- For details of the Analog\_output(2)\_characteristics\_selection <G-09>, refer to {5.3.8 Area G}.



12. Press the [SET] key.

- The selection of "G-09" is confirmed, the current setting value (Initialized data is "1") is displayed.



13. Press the keys [↑] and [↓] to change the number to "0" (Output voltage).

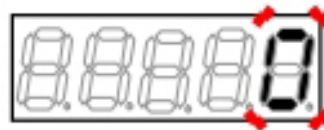

14. Press the [SET] key.

- The change is confirmed, and "G-09" is displayed again.



15. Press the [JOG/→], [↑], and [↓] keys to specify "S-09."

- For details of the Analog\_output(2)\_adjustment <S-09>, refer to {5.3.16 Area S}.



**16. Press the [SET] key.**

- "0" is displayed on the extreme right, and the underscore blinks on the extreme left.



**17. Press the [JOG/→] key to blink required digits, and then press the keys [↑] and [↓] to specify numbers to become "1040."**

**18. Press the [SET] key.**

- The password input is confirmed, and the screen returns to "S-09" display.
- When a different number from "1040" is input, "P-Err" indicating an error is displayed. In this case, press the keys [↑] and [↓] to return to "S-09." Follow the procedures again from the step 16.



Display indicating a password error

**19. Press the [SET] key.**

- Again, "0" is displayed on the extreme right, and the underscore blinks on the extreme left.



**20. Press the [JOG/→] key to blink a required digit, and then press the keys [↑] and [↓] to change the number to "1" (Analog output(2) offset adjustment).**

- The display of the setting value automatically returns to that of the setting item in ten seconds. Unless a setting value is specified while it is displayed, it cannot be changed.

**21. Press the [SET] key.**

- The change is confirmed, and "S-09" is displayed again.
- The display of the setting value automatically returns to that of the setting item in ten seconds. Unless the [SET] key is pressed while a setting value is displayed, it is not confirmed.



22. Press the [JOG/→], [↑], and [↓] keys to specify "G-09."



23. Press the [SET] key.

- The selection of "G-09" is confirmed, the current setting value "0" (Output voltage) is displayed.



24. Press the keys [↑] and [↓] to change the number to "6" (Calibration).



25. Press the [SET] key.

- The change is confirmed, and "G-09" is displayed again.



26. Press the [JOG/→], [↑], and [↓] keys to specify "S-09."



27. Press the [SET] key.

- "0" is displayed on the extreme right, and the underscore blinks on the extreme left.



28. Press the [JOG/→] key to blink required digits, and then press the keys [↑] and [↓] to specify numbers to become "1040."



**29. Press the [SET] key.**

- The password input is confirmed, and the screen returns to "S-09" display.
- When a different number from "1040" is input, "P-Err" indicating an error is displayed. In this case, press the keys [↑] and [↓] to return to "S-09." Follow the procedures again from the step 27.



Display indicating a password error

**30. Press the [SET] key.**

- Again, "0" is displayed on the extreme right, and the underscore blinks on the extreme left.

**31. Press the [JOG/→] key to blink a required digit, and then press the keys [↑] and [↓] to change the number to "2" (Analog output(2) offset adjustment).**

- The display of the setting value automatically returns to that of the setting item in ten seconds. Unless a setting value is specified while it is displayed, it cannot be changed.

**32. Press the [SET] key.**

- The display of the setting value automatically returns to that of the setting item in ten seconds. Unless the [SET] key is pressed while a setting value is displayed, it is not confirmed.
- When "S-09" is displayed again, the settings of the Analog\_output(2)\_gain <L-09> and Analog\_output(2)\_offset <L-10> are automatically changed.



**33. Press the [MONI/FNC] key.**

- The [FNC] LED turns off, after a monitor item is displayed for about one second, its data appears.

**34. Turn off the inverter, and open the front cover.****35. Remove the short-circuit wire between the terminal [AOT2] on <IO66-Z> and the terminal [AIN1] on the control board <VFC66-Z>.****36. Remove the short-circuit wire between the terminals [G] and [G-OT] on <IO66-Z>.****37. Close the front cover.**

## Chapter 6 Troubleshooting

### 6.1 Protection Messages and Actions

#### 6.1.1 Displays and Behaviors in Protection Display Mode

When the inverter starts a protection operation due to an abnormality while it operates, it stops output, and the console enters the protection display mode to display the started protection.

For notification, the protection operation blinks in the seven-segment display.

For what are displayed, refer to {6.1.2 List of Protection Messages}.

Refer to this list and then take actions as described in {6.1.3 How to Handle Protection Messages}.

■ Displays in the protection display mode

##### When a single protection starts

The started protection operation blinks.

- The protection message is prepended with "1."



##### When multiple protections start

The protection operations are numbered in the order in which they are detected, and they will blink.

- They are displayed in turn every one second.



↑ ↓



■ Behaviors of the inverter in the protection display mode

- Stop output (with some exceptions)
- Enable protection contact [86A] output

■ Operations in the protection display mode

- (1) Even during a protection operation, you can press the [MONI/FNC] key to switch to the monitor (MONI) mode or the function setting (FNC) mode to operate the inverter.
  - To handle a protection operation, you should sometimes change parameter settings.
- (2) Six types of protection operation data (such as output current) can be displayed, and a state when an abnormality occurs can be checked.
  - Refer to {6.2.1 How to Display Protection Operation Data}.
- (3) Before performing reset, find a cause of a protection operation and take any measures.
  - For how to perform reset, refer to {6.3 How to Reset Protection Display Mode}.

## 6.1.2 List of Protection Messages

The table below lists what appear in the seven-segment display on the console when the inverter starts a protection operation due to an abnormality while it operates.

Common to all models

No.	Display	Protection item	What are protected
1	ccEr1	Communication time error	It starts when a communication time error occurs between the control board <VFC66-Z> and the console board <SET66-Z>. Alternatively, it starts when a communication time error occurs between the control board <VFC66-Z> and the external console option <SET66EX-Z>.
2	cS2	Memory abnormality	It starts when setting data stored in the internal memory cannot be obtained correctly.
3	CtEr	Current sensor abnormality	[IM][EDM] It starts when the current sensor fails.
4	Cut	Open phase	[EDM] It starts when an output line is disconnected.
5	EF1	External failure 1	It starts when the multifunction input external failure 1 has been input.
6	EF2	External failure 2	It starts when the multifunction input external failure 2 has been input.
7	EF3	External failure 3	It starts when the multifunction input external failure 3 has been input.
8	EF4	External failure 4	It starts when the multifunction input external failure 4 has been input.
9	EnGA	Emergency stop (normally open) input	It starts when the multifunction input specified for the emergency stop (normally open) has been enabled.
10	EnGb	Emergency stop (normally close) input	It starts when the multifunction input specified for the emergency stop (normally close) has been unavailable. It starts when the internal PLC function is used or the Multifunction_input_place_selection <c-00> is set to "1"(Digital communication option) and also the multifunction input emergency stop has been input.
11	FCL	FCL operation	[V/f] It starts when the fast current limit protection (FCL) lasts for about 15 seconds. Operating time depends on output frequency.
12	FnF	Failed fan	Standard products do not detect this failure. This is a custom model with a cooling fan installed inside the inverter and operates when the cooling fan inside the inverter breaks down in 11 to 22 kW models. However, it does not stop for protection.
13	iGbt	IGBT protection operation	It starts when IGBT is protected from overcurrent and the gate power supply is decreased for the model below 22 kW.
14	inoH	Motor overheat protection	It starts when the Motor_overheat_protection_operation_selection is set to "ON" and motor temperature is over Motor_protect_temperature <G-17 > while the temperature detection option is used.
15	oc	Overcurrent protection	It starts when an instantaneous value of output current becomes more than or equal to a value 3.58 times a value of the rated inverter current.
16	oF	Overfrequency protection	[V/f] It starts when output frequency exceeds a value of overfrequency protection setting.
17	oH	Inverter overheat protection	It starts when temperature of IGBT becomes more than or equal to a specified value for the model below 22 kW.

No.	Display	Protection item	What are protected
18	oL	Overload protection	It starts when an effective value of output current exceeds a state where 150 % of the overload protection reference (rated motor current < A-04 > × overload protection setting < F-03 >) is output for over 60 seconds. However, the overload protection reference is limited to the rated output current.
19	oPEr	Optional error	It starts when a connected optional board malfunctions while the optional board is enabled.
20	oS	Overspeed protection	[IM] [EDM] It starts when motor speed exceeds a value of overspeed setting.
21	ot	Overtorque protection	[IM][EDM] It starts when the overtorque protection operation setting is set to ON and output torque exceeds a state where 150 % of the rated torque is developed for 60 seconds.
22	oV	Direct-current part over-voltage protection	[200 V class] It starts when voltage of the direct-current part exceeds 400 V. [400 V class] It starts when voltage of the direct-current part exceeds 800 V.
23	PEr	PG error	[EDM] It starts for no input to U, V, and W signals of the PG even after an electrical phase is repeated for two or more cycles. It starts for no input to Z signals of the PG even after a mechanical phase is repeated for two or more cycles.
24	PSL-	CPU abnormality handling	It starts when the CPU has an abnormal operation due to instantaneous reduction of control power supply 5 V. "--" in the last digit shows a number to distinguish errors.
25	roH	Charging resistance over-heat protection	It starts when charging resistance is overheated for the model below 7.5 kW.
26	SE--	Setting error	It starts when the inverter starts with incorrect settings of the rating and constants of the motor. "--" in the last two digits shows a number to represent a main cause of an incorrect setting. For details, refer to {6.1.4 Meaning of Setting Error (SE--) Display}.
27	SLSE	Start error without sensor	[EDM] It starts when a phase detection fails at start in the control without speed sensor.
28	SnE	Sensor error	[EDM] It starts for an abnormality of the current sensor, incorrect wiring of the PG, or an incorrect setting of motor d-axis positioning.
29	SPdE	Speed control error	[IM] [EDM] It starts when a deviation between motor speed and a command value (speed control input) exceeds a setting value (setting on the console) while the speed control abnormality detection is set to "ON."
30	StrF	Startup stall	It starts when the inverter cannot operate in ten seconds after an operation or JOG command is input.
31	tS	Communication timeout error	It starts when a communication error (timeout) occurs between the optional board and the communication master while the network communication option is used.

No.	Display	Protection item	What are protected
32	uV	Insufficient voltage (power failure)	[200 V class] It starts when direct-current voltage becomes less than or equal to 180 V while the inverter is running. [400 V class] It starts when direct-current voltage becomes less than or equal to 360 V while the inverter is running.

For models over 30 kW and parallel models <15022>, <18022>, <40044> through <100044>, the protection items listed below are displayed in addition to the above list.

For models of 30 to 315 kW consisting of a single unit, the protection items (related to master units) listed in the next table are displayed.

Only models over 30 kW or parallel models

No.	Display	Protection item	What are protected
33	GAc	Gate board abnormality	It starts when the protections No.34 through No.89 (except for No.45, 58, 72, and 86) start and the protection operation relay operates.
34	Gnt	Gate board communication abnormality (master unit)	It starts when an abnormality occurs in a communication with the gate board in the master unit.
35	GnP	Gate power supply abnormality (master unit)	For models over 75 kW and parallel models, it starts when the power supply of the gate in the master unit has an abnormality.
36	Gn1	IGBT (T1/U phase) protection operation (master unit)	For 30–55 kW models, it starts when overcurrent is applied to the T1/U phase IGBT in the master unit or the power supply voltage of the gate in T1/U phase is decreased. For models over 75 kW and parallel models, it starts when overcurrent is applied to the T1/U phase IGBT in the master unit.
37	Gn2	IGBT (T2/V phase) protection operation (master unit)	For 30–55 kW models, it starts when overcurrent is applied to the T2/V phase IGBT in the master unit or the power supply voltage of the gate in T2/V phase is decreased. For models over 75 kW and parallel models, it starts when overcurrent is applied to the T2/V phase IGBT in the master unit.
38	Gn3	IGBT (T3/W phase) protection operation (master unit)	For 30–55 kW models, it starts when overcurrent is applied to the T3/W phase IGBT in the master unit or the power supply voltage of the gate in T3/W phase is decreased. For models over 75 kW and parallel models, it starts when overcurrent is applied to the T3/W phase IGBT in the master unit.
39	GnH1	Unit overheat (T1/Uphase) (master unit)	It starts when heat sink temperature of the T1/U phase IGBT in the master unit becomes more than or equal to a specified value.
40	GnH2	Unit overheat (T2/V phase) (master unit)	It starts when heat sink temperature of the T2/V phase IGBT in the master unit becomes more than or equal to a specified value.
41	GnH3	Unit overheat (T3/W phase) (master unit)	It starts when heat sink temperature of the T3/W phase IGBT in the master unit becomes more than or equal to a specified value.
42	GnFu	Blown fuse (master unit)	For models over 75 kW and parallel models, it starts when the fuse of the main circuit direct-current part in the master unit is blown.
43	GFCL	FCL operation	It starts when current over 290 % of the rated inverter current is applied for two or more seconds in all units.
44	GPPE	Power supply abnormality	For parallel models, it starts when the power supply of the parallel control board has an abnormality.
45	GnFF	Failed fan (master unit)	For models over 75 kW and parallel models, it starts when the cooling fan in the master unit fails. However, it does not stop for protection. Additionally, for custom 30–55kW models with a cooling fan installed inside the inverter, it operates when the cooling fan inside the inverter fails. However, it does not stop for protection.

No.	Display	Protection item	What are protected
46	GnnC	MC response abnormality (master unit)	For models over 75 kW and parallel models, it starts when the magnetic contactor (MC) in the master unit does not turn on.
47	GncH	Converter overheat (master unit)	It starts when heat sink temperature of the converter in the master unit becomes more than or equal to a specified value.
48	G1t	Gate board communication abnormality (slave unit 1)	It starts when an abnormality occurs in a communication with the gate board in the slave unit 1.
49	G1P	Gate power supply abnormality (slave unit 1)	It starts when the gate power supply in the slave unit 1 has an abnormality.
50	G11	IGBT (T1/U phase) protection operation (slave unit 1)	It starts when overcurrent is applied to the T1/U phase IGBT in the slave unit 1.
51	G12	IGBT (T2/V phase) protection operation (slave unit 1)	It starts when overcurrent is applied to the T2/V phase IGBT in the slave unit 1.
52	G13	IGBT (T3/W phase) protection operation (slave unit 1)	It starts when overcurrent is applied to the T3/W phase IGBT in the slave unit 1.
53	G1oV	Direct-current part overvoltage (slave unit 1)	It starts when a direct-current part is protected from overvoltage in the slave unit 1. [200 V class] It starts when voltage of the direct-current part exceeds 400 V. [400 V class] It starts when voltage of the direct-current part exceeds 800 V.
54	G1H1	Unit overheat (T1/U phase) (slave unit 1)	It starts when heat sink temperature of the T1/U phase IGBT in the slave unit 1 becomes more than or equal to a specified value.
55	G1H2	Unit overheat (T2/V phase) (slave unit 1)	It starts when heat sink temperature of the T2/V phase IGBT in the slave unit 1 becomes more than or equal to a specified value.
56	G1H3	Unit overheat (T3/W phase) (slave unit 1)	It starts when heat sink temperature of the T3/W phase IGBT in the slave unit 1 becomes more than or equal to a specified value.
57	G1Fu	Blown fuse (slave unit 1)	It starts when the fuse of the main circuit direct-current part in the slave unit 1 is blown.
58	G1FF	Failed fan (slave unit 1)	It starts when the cooling fan in the slave unit 1 fails. However, it does not stop for protection.
59	G1CE	Control power supply abnormality (slave unit 1)	It starts when voltage of the control power supply in the slave unit 1 has an abnormality.
60	G1nC	MC response abnormality (slave unit 1)	It starts when the magnetic contactor (MC) in the slave unit 1 does not turn on.
61	G1cH	Converter overheat (slave unit 1)	It starts when heat sink temperature of the converter in the slave unit 1 becomes more than or equal to a specified value.
62	G2t	Gate board communication abnormality (slave unit 2)	It starts when an abnormality occurs in a communication with the gate board in the slave unit 2.
63	G2P	Gate power supply abnormality (slave unit 2)	It starts when the power supply of the gate in the slave unit 2 has an abnormality.
64	G21	IGBT (T1/U phase) protection operation (slave unit 2)	It starts when overcurrent is applied to the T1/U phase IGBT in the slave unit 2.

No.	Display	Protection item	What are protected
65	G22	IGBT (T2/V phase) protection operation (slave unit 2)	It starts when overcurrent is applied to the T2/V phase IGBT in the slave unit 2.
66	G23	IGBT (T3/W phase) protection operation (slave unit 2)	It starts when overcurrent is applied to the T3/W phase IGBT in the slave unit 2.
67	G2oV	Direct-current part overvoltage (slave unit 2)	It starts when a direct-current part is protected from overvoltage in the slave unit 2. [200 V class] It starts when voltage of the direct-current part exceeds 400 V. [400 V class] It starts when voltage of the direct-current part exceeds 800 V.
68	G2H1	Unit overheat (T1/Uphase) (slave unit 2)	It starts when heat sink temperature of the T1/U phase IGBT in the slave unit 2 becomes more than or equal to a specified value.
69	G2H2	Unit overheat (T2/V phase) (slave unit 2)	It starts when heat sink temperature of the T2/V phase IGBT in the slave unit 2 becomes more than or equal to a specified value.
70	G2H3	Unit overheat (T3/W phase) (slave unit 2)	It starts when heat sink temperature of the T3/W phase IGBT in the slave unit 2 becomes more than or equal to a specified value.
71	G2Fu	Blown fuse (slave unit 2)	It starts when the fuse of the main circuit direct-current part in the slave unit 2 is blown.
72	G2FF	Failed fan (slave unit 2)	It starts when the cooling fan in the slave unit 2 fails. However, it does not stop for protection.
73	G2CE	Control power supply abnormality (slave unit 2)	It starts when voltage of the control power supply in the slave unit 2 is decreased.
74	G2nC	MC response abnormality (slave unit 2)	It starts when the magnetic contactor (MC) in the slave unit 2 does not turn on.
75	G2cH	Converter overheat (slave unit 2)	It starts when heat sink temperature of the converter in the slave unit 2 becomes more than or equal to a specified value.
76	G3t	Gate board communication abnormality (slave unit 3)	It starts when an abnormality occurs in a communication with the gate board in the slave unit 3.
77	G3P	Gate power supply abnormality (slave unit 3)	It starts when the power supply of the gate in the slave unit 3 has an abnormality.
78	G31	IGBT (T1/U phase) protection operation (slave unit 3)	It starts when overcurrent is applied to the T1/U phase IGBT in the slave unit 3.
79	G32	IGBT (T2/V phase) protection operation (slave unit 3)	It starts when overcurrent is applied to the T2/V phase IGBT in the slave unit 3.
80	G33	IGBT (T3/W phase) protection operation (slave unit 3)	It starts when overcurrent is applied to the T3/W phase IGBT in the slave unit 3.
81	G3oV	Direct-current part overvoltage (slave unit 3)	It starts when a direct-current part is protected from overvoltage in the slave unit 3. [200 V class] It starts when voltage of the direct-current part exceeds 400 V. [400 V class] It starts when voltage of the direct-current part exceeds 800 V.

No.	Display	Protection item	What are protected
82	G3H1	Unit overheat (T1/U phase) (slave unit 3)	It starts when heat sink temperature of the T1/U phase IGBT in the slave unit 3 becomes more than or equal to a specified value.
83	G3H2	Unit overheat (T2/V phase) (slave unit 3)	It starts when heat sink temperature of the T2/V phase IGBT in the slave unit 3 becomes more than or equal to a specified value.
84	G3H3	Unit overheat (T3/W phase) (slave unit 3)	It starts when heat sink temperature of the T3/W phase IGBT in the slave unit 3 becomes more than or equal to a specified value.
85	G3Fu	Blown fuse (slave unit 3)	It starts when the fuse of the main circuit direct-current part in the slave unit 3 is blown.
86	G3FF	Failed fan (slave unit 3)	It starts when the cooling fan in the slave unit 3 fails. However, it does not stop for protection.
87	G3CE	Control power supply abnormality (slave unit 3)	It starts when voltage of the control power supply in the slave unit 3 is decreased.
88	G3nC	MC response abnormality (slave unit 3)	It starts when the magnetic contactor (MC) in the slave unit 3 does not turn on.
89	G3cH	Converter overheat (slave unit 3)	It starts when heat sink temperature of the converter in the slave unit 3 becomes more than or equal to a specified value.
90	db1	VFDB1 (dynamic braking unit 1) abnormality	It starts when the VFDB1 (dynamic braking (DB) optional unit 1) is in the protection state or has a communication abnormality. However, it does not stop for protection.
91	db2	VFDB2 (dynamic braking unit 2) abnormality	It starts when the VFDB2 (dynamic braking (DB) optional unit 2) is in the protection state or has a communication abnormality. However, it does not stop for protection.
92	db3	VFDB3 (dynamic braking unit 3) abnormality	It starts when the VFDB3 (dynamic braking (DB) optional unit 3) is in the protection state or has a communication abnormality. However, it does not stop for protection.
93	db4	VFDB4 (dynamic braking unit 4) abnormality	It starts when the VFDB4 (dynamic braking (DB) optional unit 4) is in the protection state or has a communication abnormality. However, it does not stop for protection.
94	db5	VFDB5 (dynamic braking unit 5) abnormality	It starts when the VFDB5 (dynamic braking (DB) optional unit 5) is in the protection state or has a communication abnormality. However, it does not stop for protection.
95	db6	VFDB6 (dynamic braking unit 6) abnormality	It starts when the VFDB6 (dynamic braking (DB) optional unit 6) is in the protection state or has a communication abnormality. However, it does not stop for protection.

For No.90 through No.95, you can use <J-15> to set whether or not it stops for protection. For details, refer to {5.3.11 Area J}.

### 6.1.3 How to Handle Protection Messages

When the inverter starts a protection operation due to an abnormality while it operates, you should follow instructions in the seven-segment display to take actions listed below.

■ Common to all models

Display	Cause	Where to check and how to take actions	Reference
ccEr1	Connectors of the console are not inserted correctly.	Check that they are inserted correctly.	
	The control board <VFC66-Z> is in the program rewrite mode.	After rewriting of the program is completed, it is automatically restored.	
	The control board <VFC66-Z> malfunctions.	Replace the control board <VFC66-Z>.	8.2 How to Replace Control Board

Display	Cause	Where to check and how to take actions	Reference
cS2	Data was written incorrectly to the EEPROM (internal memory) due to too much noise.	Take measures against noise for a wiring from the control board <VFC66-Z>.	3.5.1 Notes for Wiring
	The uninitialized control board <VFC66-Z> was implemented.	Initialize the control board <VFC66-Z>.	8.3 How to Initialize Inverter Main Unit
	Faulty EEPROM (internal memory) parts.	Replace the control board <VFC66-Z>.	8.2 How to Replace Control Board

Display	Cause	Where to check and how to take actions	Reference
CtEr	The current sensor malfunctions or fails.	<ul style="list-style-type: none"> <li>▪ Replace the current sensor.</li> <li>▪ Replace the main circuit board &lt;MAC66&gt;.</li> </ul>	Contact us.
	One of inverter output electrical wires is grounded.	Check whether it is grounded or not.	

Display	Cause	Where to check and how to take actions	Reference
Cut	The inverter is operated while the output side of the inverter is blocked such as the case the output side of the magnetic contactor(MC) is blocked. Or the output electrical wire is disconnected.	Turn off the inverter and check whether the output side of the inverter is blocked or not such as disconnection of the output electrical wire or state of the magnetic contactor(MC).	3.3 How to Connect Inverter

Display	Cause	Where to check and how to take actions	Reference
EF1	The external failure signal was input.	Check conditions where it is input.	
EF2 EF3 EF4	Multifunction input settings are not correct.	Check multifunction input settings <c-00> through <c-17>.	5.3.4 Area c

Display	Cause	Where to check and how to take actions	Reference
EnGA	(It is not a protection message.)		
EnGb	(It is not a protection message.)		

Display	Cause	Where to check and how to take actions	Reference
FCL	The output electrical wire is grounded or short circuited.	Check the wiring of the output electrical wire.	3.3 How to Connect Inverter
	[V/f] Acceleration or deceleration time is too short.	Make it longer.	4.4.2 Changing Acceleration or Deceleration Time
	Load capacity abnormally becomes large.	Reduce load, and check and review the capacity of the inverter and the motor.	3.6 Inverter Selection and List of Applied Motors
	The setting value of Autotuning is not correct.	Perform Full Mode Autotuning again.	4.3.3 How to Perform Autotuning
	The combination of the inverter with the motor is incorrect.	Use the correct combination of the inverter with the motor.	3.6 Inverter Selection and List of Applied Motors
	[IM] [EDM] The setting of current control gain is not correct.	Adjust settings of current control gain < E-07 > through < E-09 >.	5.3.6 Area E
	When the rated voltage was directly applied to the motor to start the inverter (full voltage starting), it could not accelerate.	Stop applying the rated voltage to the motor directly (direct applying), and change it to the normal start.	
	The motor with the phase advanced capacitor is used.	Remove the phase advanced capacitor.	

Display	Cause	Where to check and how to take actions	Reference
FnF	The cooling fan of the inverter fails.	Check the cooling fan of the inverter.	

Display	Cause	Where to check and how to take actions	Reference
iGbt	Ambient temperature becomes high.	<ul style="list-style-type: none"> <li>Check the installation environment.</li> <li>Check whether temperature inside the control panel rises or not.</li> </ul>	3.1.2 How to Install Inverter
	Cooling space of the inverter is not enough.	Keep enough cooling space.	3.1.2 How to Install Inverter
	The installation direction of the inverter is not correct.	Install it in the correct direction.	3.1.2 How to Install Inverter
	The output electrical wire is grounded or short circuited.	Check the wiring of the output electrical wire.	3.3 How to Connect Inverter
	The direct-current reactor (DCL) is not connected.	Connect the direct-current reactor (DCL).	3.3 How to Connect Inverter
	IGBT is damaged.	Check whether IGBT works properly or not (continuity check).	
	The cooling fan fails.	Replace the cooling fan.	7.3 How to Replace Cooling Fan
	The wind of the cooling fan blows in the reverse direction.	Install it so that the wind blows in the correct direction.	7.3 How to Replace Cooling Fan
	The inverter continuously operated at low frequencies of 10 Hz or less.	Reduce the capacity according to the capacity curve when the inverter operates at low frequencies.	
The main circuit board <MAC66> or the gate board <GAC66> malfunctions.	Replace the main circuit board <MAC66> or the gate board <GAC66>.		

Display	Cause	Where to check and how to take actions	Reference
inoH	The cooling fan of the motor fails.	The cooling fan of the motor fails.	
	Ambient temperature of the motor is high.	Check the installation environment of the motor.	
	The motor temperature detection electrical wire is disconnected, or noise is contaminated.	<ul style="list-style-type: none"> <li>Check the wiring of the motor temperature detection electrical wire.</li> <li>Take any measures against noise.</li> </ul>	
	Settings of motor temperature detection gain <G-01> and <G-02> are not adjusted correctly.	Readjust the settings of motor temperature detection gain <G-01> and <G-02>.	5.3.8 Area G

Display	Cause	Where to check and how to take actions	Reference
oc	The output electrical wire is grounded or short circuited.	Check the wiring of the output electrical wire.	3.3 How to Connect Inverter
	[V/f] Acceleration or deceleration time is too short.	Make it longer.	4.4.2 Changing Acceleration or Deceleration Time
	Load capacity abnormally becomes large.	<ul style="list-style-type: none"> <li>▪ Reduce load.</li> <li>▪ Check and review the capacity of the inverter and the motor.</li> </ul>	3.6 Inverter Selection and List of Applied Motors
	The setting value of Autotuning is not correct.	Perform Full Mode Autotuning again.	4.3.3 How to Perform Autotuning
	The combination of the inverter with the motor is incorrect.	Use the correct combination of the inverter with the motor.	3.6 Inverter Selection and List of Applied Motors
	[IM] [EDM] The setting of current control gain is not correct.	Adjust settings of current control gain <E-07> through <E-09>.	5.3.6 Area E
	When the rated voltage was directly applied to the motor to start the inverter (direct applying start), it could not accelerate.	Stop applying the rated voltage to the motor directly (direct applying), and change it to the normal start.	
	The motor with the phase advanced capacitor is used.	Remove the phase advanced capacitor.	

Display	Cause	Where to check and how to take actions	Reference
oF	The external frequency setting device malfunctions.	Check behaviors of the external frequency setting device.	4.6 Changing Speed through Voltage Setting Device/ Variable Resistor in V/f Control
	Setting values of overfrequency protection <F-01> and <F-02> are not correct.	Review setting values of overfrequency protection <F-01> and <F-02>.	5.3.7 Area F

Display	Cause	Where to check and how to take actions	Reference
oH	The cooling fan of the inverter fails or malfunctions.	Replace the cooling fan of the inverter.	
	Ambient temperature is high, or cooling space of the inverter is not enough.	Check the installation environment, and check that cooling space is enough.	3.1.2 How to Install Inverter
	The installation direction of the inverter is not correct.	Install it in the correct direction.	3.1.2 How to Install Inverter
	A value over Initialized data is set to the PWM_carrier_frequency.	Set a value below Initialized data to the PWM_carrier_frequency <A-09>, or reduce load capacity.	5.3.2 Area A

Display	Cause	Where to check and how to take actions	Reference
oL	The capacity of the inverter and the motor is too small.	<ul style="list-style-type: none"> <li>▪ Reduce load.</li> <li>▪ Check and review the capacity of the inverter and the motor.</li> </ul>	3.6 Inverter Selection and List of Applied Motors
	Settings of rated motor values <A-02> through <A-07> are not correct.	Check and review settings of rated motor values <A-02> through <A-07>.	4.3.2 Requirements for Performing Autotuning
	[V/f] Rotation of the motor stalls (motor stall).	Check and review settings of torque limit values <b-13> through <b-16>.	5.3.3 Area b
	A value of the overload protection setting for overload protection is not correct.	Check and review a setting value of the Overload_protection_setting <F-03>.	5.3.7 Area F
	Load capacity abnormally becomes large.	Use the Overload_protection_pre-alarm_operation_level_setting <H-11>.	5.3.9 Area H

Display	Cause	Where to check and how to take actions	Reference
oPEr	The Digital_communication_option_selection <J-00> is set to "ON" without the digital communication option connected.	Set the Digital_communication_option_selection <J-00> to "OFF."	5.3.11 Area J
	The digital communication option malfunctions.	Replace the digital communication option.	Optional Instruction Manual
	The digital communication option is not connected tightly.	Check the connection with the digital communication option is correct and that the connector is inserted properly.	Optional Instruction Manual

Display	Cause	Where to check and how to take actions	Reference
oS	The external speed setting device malfunctions.	Check behaviors of the external speed setting device.	
	[IM][EDM] Incorrect settings of speed control gain <7.ASrP>, <8.ASrI>, and <9.ASrJ> cause overshoot.	Readjust the settings of speed control gain <7.ASrP>, <8.ASrI>, and <9.ASrJ>.	5.3.1 Basic setting area
	Load is smaller than a torque command value in the torque control mode.	Review the torque command value. However, a torque command value depends on a setting of the Torque_command_input_place_selection <i-08>.	5.3.10 Area i
	Setting values of overspeed protection <F-01> and <F-02> are not correct.	Review setting values of overspeed protection <F-01> and <F-02>.	5.3.7 Area F

Display	Cause	Where to check and how to take actions	Reference
ot	The external torque command setting device malfunctions.	Check behaviors of the external torque command setting device. However, a torque command value depends on a setting of the Torque_command_input_place_selection <i-08>.	5.3.10 Area i
	Setting values of overtorque protection functions <F-27> through <F-29> are not correct.	Review setting values of overtorque protection functions <F-27> through <F-29>.	5.3.7 Area F
	Load capacity is abnormally large.	<ul style="list-style-type: none"> <li>▪ Reduce load.</li> <li>▪ Check and review the capacity of the inverter and the motor.</li> </ul>	3.6 Inverter Selection and List of Applied Motors

Display	Cause	Where to check and how to take actions	Reference
oV	The output electrical wire is grounded or short circuited.	Check the wiring of the output electrical wire.	3.3 How to Connect Inverter
	Deceleration time is too short.	<ul style="list-style-type: none"> <li>▪ Make it longer.</li> <li>▪ Use the Regeneration_stall_prevention_function_usage_selection &lt;E-00&gt;.</li> <li>▪ Connect the dynamic braking (DB) optional unit.</li> </ul>	<ul style="list-style-type: none"> <li>▪ 4.4.2 Changing Acceleration or Deceleration Time</li> <li>▪ 5.3.6 Area E</li> <li>▪ Optional Instruction Manual</li> </ul>
	The setting of the built-in dynamic braking (DB) operation voltage is not correct.	Adjust the setting of the Built-in_DB (DynamicBrake)_operation_level <F-00>.	5.3.7 Area F
	The dynamic braking (DB) optional unit does not work.	Replace the dynamic braking (DB) optional unit.	Optional Instruction Manual
	Load inertia becomes large.	Use the sine wave converter or the dynamic braking (DB) optional unit.	Optional Instruction Manual
	Input power supply voltage abnormally rises.	Check input power supply voltage.	

Display	Cause	Where to check and how to take actions	Reference
PEr	The speed sensor (PG) and the inverter are not wired.	Check the wiring.	3.3.2 How to Connect Speed Sensor and PG Input Board
	U, V, and W signals of the speed sensor (PG) have an abnormality due to noise.		
	The setting of the Number_of_PG-pulse <A-08> is incorrect.	Check the setting of the Number_of_PG-pulse <A-08>.	5.3.2 Area A
	The U, V, and W signal wires of the speed sensor (PG) or the Z signal wire are disconnected.	Check the wiring.	3.3.2 How to Connect Speed Sensor and PG Input Board
	The power supply of the speed sensor (PG) has an abnormality.		

Display	Cause	Where to check and how to take actions	Reference
PSL-	It is displayed due to instantaneous reduction of control power supply 5 V.	<ul style="list-style-type: none"> <li>▪ Check the connection of [CN1] on the control board &lt;VFC66-Z&gt;.</li> <li>▪ When the PG input board &lt;PG66-Z&gt; and the optional board are connected, check the connections of [CN4] and [CN7] on the control board &lt;VFC66-Z&gt;.</li> </ul>	8.2 How to Replace Control Board (Note) When this problem is not solved even after both actions are taken, you should contact us.
	The control board <VFC66-Z> and the main circuit board <MAC66> malfunction.	Replace the board.	

Display	Cause	Where to check and how to take actions	Reference
roH	The inverter operated for over 0.5 second while temperature of charging resistance becomes higher.	Turn off the inverter, and after a while turn it on again.	3.1.2 How to Install Inverter
	Ambient temperature is high, or cooling space of the inverter is not enough.	Check the installation environment, and check that cooling space is enough.	

Display	Cause	Where to check and how to take actions	Reference
SE--	Setting errors of the rating and constant of the motor. For details, refer to {6.1.4 Meaning of Setting Error (SE--)} Display}.	Refer to {6.1.4 Meaning of Setting Error (SE--)} Display}.	6.1.4 Meaning of Setting Error (SE--) Display

Display	Cause	Where to check and how to take actions	Reference
SLSE	Phase detection failed at start.	Check the combination of the motor with the inverter.	3.6 Inverter Selection and List of Applied Motors

Display	Cause	Where to check and how to take actions	Reference
SnE	The speed sensor (PG) and the inverter are not wired or wired incorrectly.	Check the wiring.	3.3.2 How to Connect Speed Sensor and PG Input Board
	The current sensor malfunctions or fails.	<ul style="list-style-type: none"> <li>▪ Replace the current sensor.</li> <li>▪ Replace the main circuit board &lt;MAC66&gt;.</li> </ul>	Contact us.
	The setting of the motor_d-axis_position <A-30> is not correct.	Perform D-axis Autotuning.	4.3 Autotuning of Parameters (Automatic Setting)
	Settings of motor constants <A-16> through <A-33> are not correct.	Full Mode Autotuning	

Display	Cause	Where to check and how to take actions	Reference
SPdE	Setting values of speed control error detection speed width <F-31> and <F-32> are not correct.	Adjust setting values of speed control error detection speed width <F-31> and <F-32>.	5.3.7 Area F
	Torque was limited due to heavy load.	Reduce load.	
	Torque was limited due to short acceleration or deceleration time.	Make it longer.	4.4.2 Changing Acceleration or Deceleration Time
	The external speed setting device malfunctions.	Check behaviors of the external speed setting device.	
	The connection between the inverter output terminal and the motor is not correct.	Check the connection between the inverter and the motor.	3.3 How to Connect Inverter

Display	Cause	Where to check and how to take actions	Reference
StrF	An operation or JOG command was input for over ten seconds after insufficient voltage (power failure) was detected.	Set the Instantaneous_power_interruption_restart <b-07> to "ON."	5.3.3 Area b
	An operation or JOG command was input for over ten seconds while an emergency stop signal was input.	Turn off the operation or JOG signal while the emergency stop signal is input.	

Display	Cause	Where to check and how to take actions	Reference
tS	The communication master malfunctions.	Check behaviors of the communication master.	
	The connection cable between the digital communication option and the communication master is disconnected, and the connector is not inserted correctly.	Check that the connector is inserted correctly, and replace the connection cable.	Optional Instruction Manual

Display	Cause	Where to check and how to take actions	Reference
uV	The input power supply was interrupted (instantaneous power interruption) during operation.	Set the Instantaneous_power_interruption_restart <b-07> to "ON."	5.3.3 Area b
	Open phase occurred in the input power supply.	Check the input power supply.	

■ Models over 30 kW and parallel models

For models of 30 to 315 kW consisting of a single unit, the items (related to master units) listed below are displayed.

Parallel models are <15022>, <18022>, and <40044> through <100044>.

Display	Cause	Where to check and how to take actions	Reference
GAc	The protections No.34 through No.89 listed in [6.1.2 List of Protection Messages] started.	Clear the protection operations No.34 through No.89 in [6.1.2 List of Protection Messages] which are displayed at that time.	6.1.2 List of Protection Messages

Display	Cause	Where to check and how to take actions	Reference
Gnt	The gate board <GAC66> malfunctions.	Replace the gate board <GAC66>.	
G1t G2t G3t	The connection cable between the gate board <GAC66> in the master unit and the gate board <GAC66-Z> in the slave unit or the gate board <GAC66> in the slave unit is disconnected. The connector is not inserted correctly.	<ul style="list-style-type: none"> <li>▪ Check that the connector is inserted correctly.</li> <li>▪ Replace the connection cable.</li> </ul>	

\* A character in the second digit from the right distinguishes a master unit (n) from slave units (1, 2, and 3).

Display	Cause	Where to check and how to take actions	Reference
GnP G1P G2P G3P	The gate power supply of the gate board <GAC66> was decreased.	Replace the displayed gate board <GAC66> of the inverter.	

\* A character in the second digit from the right distinguishes a master unit (n) from slave units (1, 2, and 3).

Display	Cause	Where to check and how to take actions	Reference
Gn1 G11 G21 G31 Gn2 G12 G22 G32	The output electrical wire was short circuited or grounded.	Check the wiring of the output electrical wire.	3.3 How to Connect Inverter
	IGBT may be damaged.	Check whether IGBT of the inverter works properly or not (continuity check).	
	Autotuning has not been performed.	Perform Autotuning.	4.3 Autotuning of Parameters (Automatic Setting)
Gn3 G13 G23 G33	Acceleration or deceleration time is too short.	Make it longer.	4.4.2 Changing Acceleration or Deceleration Time
	Load capacity is abnormally large. The rated voltage was directly applied to the motor.	Reduce load. Review the capacity of the inverter and the motor.	3.6 Inverter Selection and List of Applied Motors
	[V/f] Settings related to V/f are not correct.	Check the motor nameplate and review setting values of <A-02> through <A-07>.	5.3.2 Area A
	The inverter continuously operated at low frequencies of 10 Hz or less.	Reduce the capacity according to the capacity degression curve when the inverter operates at low frequencies.	
	The gate board <GAC66> malfunctions.	Replace the gate board <GAC66> of the inverter.	

- \* A character in the second digit from the right distinguishes a master unit (n) from slave units (1, 2, and 3).
- \* A number in the rightmost digit shows the T1/U phase (1), T2/V phase (2), and T3/W phase (3).

Display	Cause	Where to check and how to take actions	Reference
GnH1 G1H1 G2H1 G3H1 GnH2 G1H2 G2H2 G3H2 GnH3 G1H3 G2H3 G3H3	Since the cooling fan of the inverter fails or malfunctions, it stops or its air volume is decreased.	Replace the cooling fan.	7.3 How to Replace Cooling Fan
	The wind of the cooling fan of the inverter blows in the reverse direction.	Install it so that the wind blows in the correct direction.	7.3 How to Replace Cooling Fan
	Ambient temperature is high.	Check temperature in the installation environment (such as temperature inside the control panel) for ventilation.	3.1.2 How to Install Inverter
	Cooling space of the inverter is not enough.	Keep enough cooling space around the inverter.	3.1.2 How to Install Inverter
	The installation direction of the inverter is not correct.	Install it in the correct direction.	3.1.2 How to Install Inverter
	The heat sink temperature sensor malfunctions.	Measure resistance of the heat sink temperature sensor.	

- \* A character in the third digit from the right distinguishes a master unit (n) from slave units (1, 2, and 3).
- \* A number in the rightmost digit shows the T1/U phase (1), T2/V phase (2), and T3/W phase (3).

Display	Cause	Where to check and how to take actions	Reference
GnFu G1Fu G2Fu G3Fu	The power supply was connected to the inverter output terminal.	Check the wiring of input and output electrical wires. After correcting it, replace the fuse of the main circuit direct-current part.	3.3 How to Connect Inverter
	IGBT may be damaged.	Check whether IGBT works properly or not (continuity check), and then replace the fuse of the main circuit direct-current part.	
	The output electrical wire was grounded or short circuited.	Check input and output wires. After correcting them, replace the damaged parts and the fuse of the main circuit direct-current part.	
	The dynamic braking (DB) optional unit was damaged.	Replace the dynamic braking (DB) optional unit.	

\* A character in the third digit from the right distinguishes a master unit (n) from slave units (1, 2, and 3).

Display	Cause	Where to check and how to take actions	Reference
GFCL	The output electrical wire is grounded or short circuited.	Check the wiring of the output electrical wire.	3.3 How to Connect Inverter
	[V/f] Acceleration or deceleration time is too short.	Make it longer.	4.4.2 Changing Acceleration or Deceleration Time
	Load capacity abnormally becomes large.	<ul style="list-style-type: none"> <li>▪ Reduce load.</li> <li>▪ Check and review the capacity of the inverter and the motor.</li> </ul>	3.6 Inverter Selection and List of Applied Motors
	The setting value of Autotuning is not correct.	Perform Full Mode Autotuning again.	4.3.3 How to Perform Autotuning
	The combination of the inverter with the motor is incorrect.	Use the correct combination of the inverter with the motor.	3.6 Inverter Selection and List of Applied Motors
	[IM] [EDM] The setting of current control gain is not correct.	Adjust settings of current control gain < E-07 > through < E-09 >.	5.3.6 Area E
	When the rated voltage was directly applied to the motor to start the inverter (direct applying start), it could not accelerate.	Stop applying the rated voltage to the motor directly (direct applying), and change it to the normal start.	
	The motor with the phase advanced capacitor is used.	Remove the phase advanced capacitor.	

Display	Cause	Where to check and how to take actions	Reference
GPPE	The power supplies of the parallel control board <PRIM66-Z> in the master unit and the parallel control board <PRIS66-Z> in the slave unit failed.	Replace the parallel control board <PRIM66-Z> or <PRIS66-Z>.	
	<GAC66-Z-CN-PS24V> through <PRIM66-Z-CN9> in the master unit and <GAC66-Z-CN-PS24V> through <PRIS66-Z-CN-PS> in the slave unit are not wired.	Wire them correctly.	

Display	Cause	Where to check and how to take actions	Reference
GnFF	The cooling fan fails.	Check and replace the cooling fan.	
G1FF G2FF G3FF	The power supply for the cooling fan is decreased.	Replace the power supply board <PSFM66>.	
	The wire between the gate board <GAC66> and the power supply board <PSFM66> is disconnected or incorrect.	Correct it.	
	The relay for turning on/off the cooling fan is not enabled.	Replace the power supply board <PSFM66>.	

\* A character in the third digit from the right distinguishes a master unit (n) from slave units (1, 2, and 3).

Display	Cause	Where to check and how to take actions	Reference
G1CE G2CE G3CE	The gate board <GAC66> malfunctions.	Replace the displayed gate board <GAC66> in the slave unit.	

\* A number in the third digit from the right shows slave units (1, 2, and 3).

Display	Cause	Where to check and how to take actions	Reference
G1oV G2oV G3oV	Deceleration time is too short.	<ul style="list-style-type: none"> <li>▪ Make it longer.</li> <li>▪ Use the Regeneration_stall_prevention_function_usage_selection &lt;E-00&gt;.</li> <li>▪ Connect the dynamic braking (DB) optional unit.</li> </ul>	<ul style="list-style-type: none"> <li>▪ 4.4.2 Changing Acceleration or Deceleration Time</li> <li>▪ 5.3.6 Area E</li> <li>▪ Optional Instruction Manual</li> </ul>
	The setting of operation voltage of the dynamic braking (DB) optional unit is not correct.	Adjust operation voltage.	Optional Instruction Manual
	The dynamic braking (DB) optional unit does not work.	Replace the dynamic braking (DB) optional unit.	Optional Instruction Manual
	Input power supply voltage abnormally rises.	Check input power supply voltage.	
	Load inertia is large.	Use the sine wave converter or the dynamic braking (DB) optional unit.	Optional Instruction Manual
	The output electrical wire was grounded or short circuited.	Check the wiring of the output electrical wire.	

\* A number in the third digit from the right shows slave units (1, 2, and 3).

Display	Cause	Where to check and how to take actions	Reference
GnnC G1nC G2nC G3nC	The power supply board <PSFM66> malfunctions.	Replace the power supply board <PSFM66>.	
	The connector between the gate board <GAC66> and the power supply board <PSFM66> is not connected correctly.	Check the connection of the connector.	
	The magnetic contactor (MC) malfunctions.	Replace the magnetic contactor (MC).	

\* A character in the third digit from the right distinguishes a master unit (n) from slave units (1, 2, and 3).

Display	Cause	Where to check and how to take actions	Reference
GncH G1cH	The cooling fan of the converter unit fails.	Replace the cooling fan.	7.3 How to Replace Cooling Fan
G2cH G3cH	Cooling space of the converter unit is not enough.	Keep enough cooling space.	3.1.2 How to Install Inverter
	The installation direction of the inverter is not correct.	Install it correctly.	3.1.2 How to Install Inverter
	The direct-current reactor (DCL) is not installed.	Connect the direct-current reactor (DCL).	3.3.1 How to Connect Inverter Terminals
	The heat sink temperature detection sensor malfunctions.	Check the heat sink temperature detection sensor for continuity.	

\* A character in the third digit from the right distinguishes a master unit (n) from slave units (1, 2, and 3).

Display	Cause	Where to check and how to take actions	Reference
db1 db2	The dynamic braking (DB) optional unit malfunctions.	Replace the dynamic braking (DB) optional unit.	
db3 db4 db5 db6	The connection cable between the board <VFDB2009-Z> on the dynamic braking (DB) optional unit and the gate board <GAC66> of the inverter is disconnected. The connector is not inserted correctly.	<ul style="list-style-type: none"> <li>▪ Check that the connector is inserted correctly.</li> <li>▪ Replace the connection cable.</li> </ul>	

\* A number in the rightmost digit shows the dynamic braking (DB) optional units <VFDB2009> (1 through 6).

### 6.1.4 Meaning of Setting Error (SE--) Display

■ When a setting error is displayed

For setting values of the parameters <A-00> through <A-07>, check each rated value described in your motor nameplate or data sheet.

For details of each parameter, refer to {5.3.2 Area A}. For other settings, contact us.

■ List of setting errors

Display	[V/f]	[IM]	[EDM]
SE00	• A smaller value is set to the Rated_motor_current <A-04>.		
SE01	• The value of the Rated_motor_voltage <A-03> is set to "0."	• A larger value is set to the Maximum_speed <A-00>.	
SE02	• The value of the Rated_motor_capacity <A-02> is set to "0."	• The value of the Rated_motor_voltage <A-03> is set to "0."	
SE03	• A larger value is set to the Rated_motor_current <A-04>.	• The value of the Rated_motor_capacity <A-02> is set to "0."	
SE04	• The values of the Rated_motor_speed <A-05> and the Rated_motor_frequency <A-07> are set to "0."	• The value of the Rated_motor_speed <A-05> is set to "0."	• Larger values are set to the Maximum_speed <A-00> and the Number_of_motor_pole <A-06>.
SE05	—	• Larger values are set to the Maximum_speed <A-00> and the Number_of_motor_pole <A-06>.	• A larger value is set to the Rated_motor_current <A-04>.
SE06	• A larger value is set to the Maximum_frequency <A-00>.	• A smaller value is set to the Rated_motor_frequency <A-07>.	• A smaller value is set to the Rated_motor_current <A-04>.
SE07	• A smaller value is set to the Rated_motor_voltage <A-03>. • A larger value is set to the Rated_motor_frequency <A-07>.	• The value of the Rated_motor_current <A-04> is set to "0."	—
SE08	• A larger value is set to the Motor_primary_resistance <A-17> by Autotuning.	• A larger value is set to the Rated_motor_current <A-04>.	—
SE09	• Larger values are set to the Rated_motor_current <A-04> and the Rated_motor_frequency <A-07>.	—	• A larger value is set to the Rated_motor_voltage <A-03>.

Display	[V/f]	[IM]	[EDM]
SE10	<ul style="list-style-type: none"> <li>• Larger values are set to the Rated_motor_voltage &lt;A-03&gt;, the Rated_motor_speed &lt;A-05&gt;, and the Number_of_motor_pole &lt;A-06&gt;.</li> <li>• Smaller values are set to the Rated_motor_capacity &lt;A-02&gt; and the Rated_motor_frequency &lt;A-07&gt;.</li> </ul>	<ul style="list-style-type: none"> <li>• Smaller values are set to the Maximum_speed &lt;A-00&gt; and the Number_of_motor_pole &lt;A-06&gt;.</li> </ul>	<ul style="list-style-type: none"> <li>• A smaller value is set to the Rated_motor_current &lt;A-04&gt;.</li> </ul>
SE11	<ul style="list-style-type: none"> <li>• A larger value is set to the Rated_motor_voltage &lt;A-03&gt;.</li> <li>• Smaller values are set to the Rated_motor_current &lt;A-04&gt; and the Rated_motor_frequency &lt;A-07&gt;.</li> </ul>		<ul style="list-style-type: none"> <li>• A larger value is set to the Current_control_proportion_gain &lt;E-07&gt;.</li> </ul>
SE12		<ul style="list-style-type: none"> <li>• A larger value is set to the Rated_motor_capacity &lt;A-02&gt;.</li> <li>• Smaller values are set to the Rated_motor_speed &lt;A-05&gt; and the Number_of_motor_pole &lt;A-06&gt;.</li> </ul>	<ul style="list-style-type: none"> <li>• A larger value is set to the Current_control_integral_gain(2) &lt;E-09&gt;.</li> </ul>
SE13	—	<ul style="list-style-type: none"> <li>• A larger value is set to the Rated_motor_frequency &lt;A-07&gt;.</li> <li>• A smaller value is set to the Rated_motor_voltage &lt;A-03&gt;.</li> </ul>	<ul style="list-style-type: none"> <li>• A larger value is set to the Current_control_integral_gain(1) &lt;E-08&gt;.</li> </ul>
SE14		<ul style="list-style-type: none"> <li>• A larger value is set to the Rated_motor_voltage &lt;A-03&gt;.</li> </ul>	<ul style="list-style-type: none"> <li>• A larger value is set to the Motor_q-axis_inductance &lt;A-19&gt;.</li> </ul>
SE15		<ul style="list-style-type: none"> <li>• Smaller values are set to the Rated_motor_current &lt;A-04&gt; and the Rated_motor_frequency &lt;A-07&gt;.</li> </ul>	<ul style="list-style-type: none"> <li>• A larger value is set to the Motor_d-axis_inductance &lt;A-18&gt;.</li> </ul>

Display	[V/f]	[IM]	[EDM]	
SE16		<ul style="list-style-type: none"> <li>• A smaller value is set to the PWM_carrier_frequency &lt;A-09&gt;.</li> </ul>	—	
SE17			—	
SE18			<ul style="list-style-type: none"> <li>• A smaller value is set to the PWM_carrier_frequency &lt;A-09&gt;.</li> </ul>	<ul style="list-style-type: none"> <li>• A smaller value is set to the PWM_carrier_frequency &lt;A-09&gt;.</li> </ul>
SE19				
SE20				
SE21		<ul style="list-style-type: none"> <li>• A smaller value is set to the PWM_carrier_frequency &lt;A-09&gt;.</li> </ul>	<ul style="list-style-type: none"> <li>• A smaller value is set to the PWM_carrier_frequency &lt;A-09&gt;.</li> <li>• Larger values are set to the Maximum_speed &lt;A-00&gt; and the Number_of_motor_pole &lt;A-06&gt;.</li> </ul>	<ul style="list-style-type: none"> <li>• Smaller values are set to the PWM_carrier_frequency &lt;A-09&gt; and the Motor_d-axis_inductance &lt;A-18&gt;.</li> </ul>
SE22				
SE23				
SE24		<ul style="list-style-type: none"> <li>• Smaller values are set to the PWM_carrier_frequency &lt;A-09&gt; and the Rated_motor_voltage &lt;A-03&gt;.</li> <li>• A larger value is set to the Rated_motor_frequency &lt;A-07&gt;.</li> </ul>	<ul style="list-style-type: none"> <li>• A smaller value is set to the PWM_carrier_frequency &lt;A-09&gt;.</li> </ul>	<ul style="list-style-type: none"> <li>• A smaller value is set to the PWM_carrier_frequency &lt;A-09&gt;.</li> </ul>
SE25				
SE26				
SE27		<ul style="list-style-type: none"> <li>• Values of the Motor_leakage_inductance &lt;A-19&gt; and the Motor_mutual_inductance &lt;A-20&gt; are set to "0" by Autotuning.</li> </ul>	<ul style="list-style-type: none"> <li>• Values of the Motor_leakage_inductance &lt;A-19&gt; and the Motor_mutual_inductance &lt;A-20&gt; are set to "0" by Autotuning.</li> </ul>	—
SE28				
SE29				
SE29		<ul style="list-style-type: none"> <li>• A smaller value is set to the Rated_motor_frequency &lt;A-07&gt;.</li> </ul>	<ul style="list-style-type: none"> <li>• The values of the Rated_motor_speed &lt;A-05&gt; and the Rated_motor_frequency &lt;A-07&gt; are set to "0."</li> </ul>	—
SE30				
SE31				
SE30	<ul style="list-style-type: none"> <li>• A larger value is set to the Motor_secondary_resistance &lt;A-18&gt;.</li> <li>• Smaller values are set to the Motor_leakage_inductance &lt;A-19&gt; and the Motor_mutual_inductance &lt;A-20&gt;.</li> </ul>	<ul style="list-style-type: none"> <li>• Larger values are set to the Motor_magnetic_flux &lt;A-20&gt; and the Motor_core_loss_torque_compensation &lt;A-21&gt;.</li> </ul>	<ul style="list-style-type: none"> <li>• A larger value is set to the Motor_primary_resistance &lt;A-17&gt;.</li> </ul>	
SE31				<ul style="list-style-type: none"> <li>• A larger value is set to the Maximum_speed &lt;A-00&gt;.</li> <li>• A smaller value is set to the Rated_motor_speed &lt;A-05&gt;.</li> </ul>

Display	[V/f]	[IM]	[EDM]
SE32		—	▪ A larger value is set to the Motor_primary_resistance <A-17>.
SE33		▪ Larger values are set to the Motor_mutual_inductance <A-20> and the Motor_core_loss_torque_compensation <A-23>.	—
SE34		▪ A larger value is set to the Motor_core_loss_torque_compensation <A-23>.	▪ The value of the Rated_motor_speed <A-05> is set to 0.
SE35			—
SE36			—
SE37		▪ A larger value is set to the Motor_secondary_resistance <A-18>. ▪ Smaller values are set to the Motor_leakage_inductance <A-19> and the Motor_mutual_inductance <A-20>.	▪ A larger value is set to the Motor_d-axis_inductance <A-18>.
SE38		▪ A larger value is set to the Motor_secondary_resistance <A-18>.	▪ A larger value is set to the Motor_q-axis_inductance <A-19>.
SE39			▪ A larger value is set to the Motor_magnetic_flux <A-20>.
SE40		▪ A larger value is set to the Motor_core_loss_torque_compensation <A-23>.	—
SE41		▪ A smaller value is set to the Motor_mutual_inductance <A-20>.	▪ A value below "2" is set to the PG_selection <A-10> and "0" is set to the Motor_d-axis_measurement_pulse_width <A-32>.
SE42		▪ A larger value is set to the Maximum_speed <A-00>.	▪ A value over "0" is set to the PG_selection <A-10> and "-1" is set to the Motor_d-axis_position <A-30>.
SE43		▪ A smaller value is set to the Maximum_speed <A-00>. ▪ A smaller value is set to the PWM_carrier_frequency <A-09>.	▪ A larger value is set to the Motor_q-axis_pulse_pole_determination_current <A-07>.
SE44		▪ A larger value is set to the Motor_primary_resistance <A-17>. ▪ A smaller value is set to the PWM_carrier_frequency <A-09>.	▪ A larger value is set to the Current_control_proportion_gain <E-07>.

Display	[V/f]	[IM]	[EDM]
SE45		<ul style="list-style-type: none"> <li>• A larger value is set to the Motor_mutual_inductance &lt;A-20&gt;.</li> <li>• A smaller value is set to the Motor_secondary_resistance &lt;A-18&gt;.</li> </ul>	<ul style="list-style-type: none"> <li>• A larger value is set to the Current_control_integral_gain(1) &lt;E-08&gt;.</li> </ul>
SE46		<ul style="list-style-type: none"> <li>• A larger value is set to the Current_control_proportion_gain &lt;E-07&gt;.</li> </ul>	<ul style="list-style-type: none"> <li>• A larger value is set to the Motor_d-axis_inductance &lt;A-18&gt;.</li> </ul>
SE47		<ul style="list-style-type: none"> <li>• A larger value is set to the Current_control_integral_gain(2) &lt;E-09&gt;.</li> </ul>	<ul style="list-style-type: none"> <li>• A larger value is set to the Motor_q-axis_inductance &lt;A-19&gt;.</li> </ul>
SE48		<ul style="list-style-type: none"> <li>• A larger value is set to the Current_control_integral_gain(1) &lt;E-08&gt;.</li> </ul>	—
SE49		<ul style="list-style-type: none"> <li>• A larger value is set to the Motor_secondary_resistance &lt;A-18&gt;.</li> </ul>	—
SE50		—	<ul style="list-style-type: none"> <li>• A smaller value is set to the Motor_primary_resistance &lt;A-17&gt;.</li> </ul>
SE51		<ul style="list-style-type: none"> <li>• A larger value is set to the Motor_secondary_resistance &lt;A-18&gt;.</li> </ul>	<ul style="list-style-type: none"> <li>• A smaller value is set to the Motor_d-axis_inductance &lt;A-18&gt;.</li> </ul>
SE52		<ul style="list-style-type: none"> <li>• A larger value is set to the Maximum_speed &lt;A-00&gt;.</li> </ul>	<ul style="list-style-type: none"> <li>• A smaller value is set to the Motor_q-axis_inductance &lt;A-19&gt;.</li> </ul>
SE53		<ul style="list-style-type: none"> <li>• A larger value is set to the Motor_core_loss_torque_compensation &lt;A-23&gt;.</li> </ul>	<ul style="list-style-type: none"> <li>• Smaller values are set to the Motor_d-axis_inductance &lt;A-18&gt; and the Motor_q-axis_inductance &lt;A-19&gt;.</li> </ul>
SE54		—	<ul style="list-style-type: none"> <li>• A larger value is set to the Motor_q-axis_inductance &lt;A-19&gt;.</li> </ul>
SE55		<ul style="list-style-type: none"> <li>• A smaller value is set to the Motor_secondary_resistance &lt;A-18&gt;.</li> </ul>	<ul style="list-style-type: none"> <li>• A larger value is set to the Motor_d-axis_inductance &lt;A-18&gt;.</li> </ul>
SE56			<ul style="list-style-type: none"> <li>• A larger value is set to the Motor_primary_resistance &lt;A-17&gt;.</li> </ul>
SE57		—	—
SE58		—	—

Display	[V/f]	[IM]	[EDM]
SE59		<ul style="list-style-type: none"> <li>A larger value is set to the Motor_secondary_resistance &lt;A-18&gt;.</li> </ul>	<ul style="list-style-type: none"> <li>A larger value is set to the Motor_magnetic_flux &lt;A-20&gt;.</li> </ul>
SE60		—	<ul style="list-style-type: none"> <li>Smaller values are set to the Motor_d-axis_inductance &lt;A-18&gt; and the Motor_q-axis_inductance &lt;A-19&gt;.</li> </ul>
SE61		<ul style="list-style-type: none"> <li>A smaller value is set to the Motor_primary_resistance &lt;A-17&gt;.</li> </ul>	<ul style="list-style-type: none"> <li>Smaller values are set to the Motor_primary_resistance &lt;A-17&gt;, the Motor_d-axis_inductance &lt;A-18&gt;, and the Motor_q-axis_inductance &lt;A-19&gt;.</li> </ul>
SE62		<ul style="list-style-type: none"> <li>Smaller values are set to the Motor_primary_resistance &lt;A-17&gt; and the Motor_mutual_inductance &lt;A-20&gt;.</li> </ul>	—
SE63		<ul style="list-style-type: none"> <li>A smaller value is set to the PWM_carrier_frequency &lt;A-09&gt;.</li> </ul>	—
SE64			—

### 6.1.5 Meaning of Error Displays during Autotuning

■ When an error is displayed during Autotuning

To clear an error during Autotuning, press the [STOP/RESET] key for about three seconds.

Like what are displayed at power-on, the inverter series name, capacity, and voltage are displayed.

For an error which occurs during Autotuning, contact us.

■ List of error displays during Autotuning

Display	Contents of errors
Err01	It is displayed when contents of Autotuning (Full Mode, Direct Current Mode, Motor D-axis Mode) do not correspond to the inverter control method.
Err10	It is displayed when results of Autotuning are not correct.
Err06	[IM] It is displayed when an inductance value is abnormal.
Err09	
Err07	[IM] It is displayed when a resistance value is abnormal.
Err08	[IM] It is displayed when a mutual inductance value is abnormal.
Err13	
Err16	
Err11	[IM] It is displayed when a leakage inductance value is abnormal.
Err12	
Err17	

Display	Contents of errors
Err14	[IM] It is displayed when a value of the Motor_inductance_saturation_coefficient(1) is abnormal.
Err15	[IM] It is displayed when a value of the Motor_inductance_saturation_coefficient(2) is abnormal.
Err18	[IM] It is displayed when "1" is set up to the PG_selection and the signal of the PG differs from the rotation direction of the motor.
Err34	[EDM] It is displayed when a value of the pole determination pulse width exceeds a specified value. The output side of the inverter may be blocked by operation of the magnetic contactor (MC). Check it again.
Err40	[EDM] It is displayed when a setting value of the Motor_d-axis_measurement_pulse_width is abnormal.
Err50	[EDM] It is displayed when the inverter could not accelerate during Autotuning. The rotation direction of the speed sensor (PG) does not match the rotation direction of the motor by incorrect wiring of the inverter output terminals [T1/U, T2/V, and T3/W] or the speed sensor (PG). Alternately, mounted load may be heavy. Check them again.
Err51	[EDM] It is displayed when a setting value of the Motor_magnetic_flux is abnormal.
Err54	[EDM] It is displayed when a value over "1" is set to the PG_selection and the wiring of the PG is not correct. Check the wiring of the PG.
Err55	[EDM] It is displayed when "1" to "2" are set to the PG_selection and no origin signal is input from the PG even after current reaches a specified value. The wiring of the inverter output terminals [T1/U, T2/V, and T3/W] or the wiring of the PG may be incorrect. Alternately, mounted load may be heavy. Check them again.
Err61	[EDM] It is displayed when a setting value of the Motor_d-axis_inductance is abnormal.
Err62	[EDM] It is displayed when a setting value of the Motor_q-axis_inductance is abnormal.
Err80	[EDM] It is displayed when setting values of inductance change rate through are abnormal.
Err99	It is displayed when a protection starts or the [STOP] key is pressed and then Autotuning is forcibly stopped.
ErrFF	It is displayed when Autotuning is not able to be started by protected operation.

## 6.2 How to Check Data in Protection Display Mode

### 6.2.1 How to Display Protection Operation Data

While a protection operation blinks, six types of data (such as output current) of the protection operation can be read out. This is called "one-point traceback data."

For details of displayed data, refer to {6.2.2 List of Data of Protection Operation and Protection History Display}.

#### 1. The started protection operation blinks.

- When multiple protection operations started, they are numbered and displayed in turn every one second.

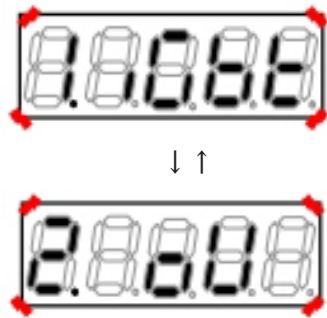

#### 2. While the desired protection operation blinks, press the [SET] key.

- Data of the protection operation (one-point traceback) is displayed.
- Six items and their data are repeatedly displayed in turn every one second.

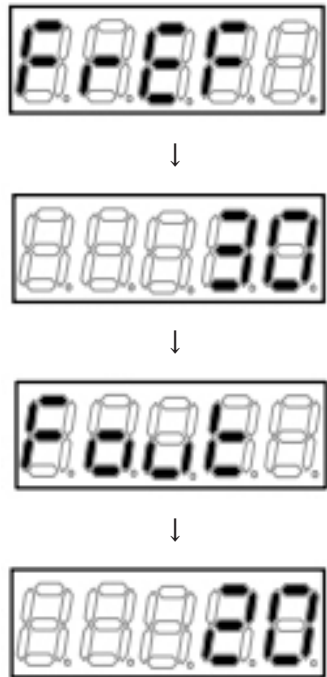

#### 3. Press the [SET] key.

- The protection operation blinks again.
- For how to reset a protection operation, refer to {6.3 How to Reset Protection Display Mode}.

### 6.2.2 List of Data of Protection Operation and Protection History Display

The tables below list data which can be checked as one-point traceback and protection history display during protection operation.

In the tables, output current shows a current value immediately before a protection operation occurs, out of

sampled values every operation period. Therefore, when current changes at fast rise (such as output short-circuit), it may not show a correct current value when the protection occurs.

[V/f]

Data item	Display	Unit	Contents	Remarks
Frequency command value	FrEF	Hz	Display a value after acceleration or deceleration control.	It is different from the display of the monitor item.
Output frequency	Fout	Hz	Display inverter output frequency.	
Output current	iout	A	Display the maximum value out of absolute three-phase current instantaneous values.	It is different from the display of the monitor item. For the sine wave, it is divided by $\sqrt{2}$ , resulting in almost equal to an effective value.
Output voltage	Vout	V	Display an effective value of voltage between output lines.	
Direct-current voltage	Vdc	V	Display direct-current voltage.	
Output torque (Torque current)	tout	%	Display a calculated value of output torque.	Accuracy is not guaranteed in the V/f control.

[IM] [EDM]

Data item	Display	Unit	Contents	Remarks
Speed command value	SrEF	r/min	Display a value after acceleration or deceleration control.	It is different from the display of the monitor item.
Motor speed	SPd	r/min	Display motor speed.	
Output current	iout	A	Display the maximum value out of absolute three-phase current instantaneous values.	It is different from the display of the monitor item. For the sine wave, it is divided by $\sqrt{2}$ , resulting in almost equal to an effective value.
Output voltage	Vout	V	Display an effective value of voltage between output lines.	
Direct-current voltage	Vdc	V	Display direct-current voltage.	
Torque command	trEF	%	Display a torque command after limit input into the torque control part is processed.	

### 6.3 How to Reset Protection Display Mode

This section describes how to reset a protection operation and to return from the protection display mode. Before performing reset, find a cause of a protection operation and take any measures.

Behaviors after reset are as follows:

- One-point traceback data described in {6.2.1 How to Display Protection Operation Data} can be no longer checked.
- Protection contact [86A] output is unavailable again.

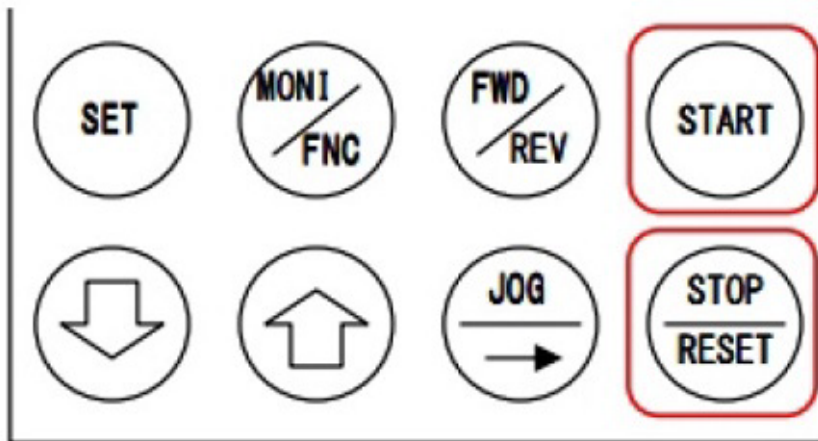

#### 1. While the protection operation blinks, press the [STOP/RESET] key.

- The protection operation is reset.
- The mode returns to the monitor (MONI) mode immediately before the protection operation starts.



When the monitor item "Fout" (output frequency) is displayed again

Even after it is reset, it may occur again.

- When a cause of the protection operation has not been solved
- When multiple protections occurred and some of them have not been solved

Check the contents of the protection message again and take any measures. If you cannot solve them, contact us.

## 6.4 How to Check Protection History

When the inverter stops due to a protection operation, it stores data such as output current and output voltage of the protection.

You can always see and check data of the last six protection histories by selecting the monitor item "trbLE." For details of displayed items, refer to {6.2.2 List of Data of Protection Operation and Protection History Display}.

### 1. When the [FNC] LED on the console turns on, press the [MONI/FNC] key.

- The [FNC] LED turns off, and the console enters the monitor (MONI) mode.
- The current monitor item is displayed for about one second, and then its data is automatically displayed.
- For details of the monitor (MONI) mode, refer to {4.1.6 Checking Operating State}. For details of monitor items, refer to {4.1.7 List of Monitor Items}.

### 2. Press either of the [SET] key, [↑] key, or [↓] key to return to the display of the monitor item.

### 3. Press either of the [SET] key, [↑] key, or [↓] key to display "trbLE" (display protection history).



- Unless a value is specified within one second while the monitor item is displayed, it cannot be changed.
- About one second later, up to last six protection operations are displayed in turn every one second.
- The protection history starting with the number "1." is the oldest.



- When there is no protection history, "-----" is displayed. Press the [SET] key to return to the display of the monitor item "trbLE."
- Press the [SET] key while the protection history is displayed to return to the display of the monitor item "trbLE."

**4. While the protection history to check data is displayed, press the [SET] key for over three seconds.**

- A data item of that protection operation is displayed.
- Six items and their data are displayed in turn every one second.



**5. Press the [SET] key.**

- The protection history is displayed again.



**6. Press the [SET] key.**

The monitor item is displayed again.

### Clearing protection history

You can clear the stored protection history with <S-00>. For details, refer to {5.3.16 Area S}.

## Chapter 7 Maintenance and Inspection

### 7.1 Periodic Inspection

To always keep the best condition of devices and to maximize their best performance, conduct a periodic inspection at least once every six months to check issues which cannot be found in a normal monitoring. Persons with safety knowledge of electricity should conduct maintenance and inspection. For how to open the front cover, refer to {3.2 How to Open and Close Front Cover}.

#### WARNING Tasks of inspection

- Never open the front cover with the input power supply turned on.  
It may result in a risk of electric shock.
- Turn off the inverter, open the front cover, and then check that the LED for checking "CHG" on the main circuit board <MAC66> or the gate board <GAC66> turns off. After that, conduct an inspection.  
It may result in a risk of electric shock.  
Otherwise, you may be injured.

#### CAUTION Tasks of inspection

- Note that temperature of the heat sink may be high depending on operating conditions.  
You may get burned.

#### WARNING Maintenance and inspection

- Before conducting an inspection, turn off the input power supply and wait for ten or more minutes. Also, check voltage between the direct-current terminals [+2] and [-] on the main circuit terminal block to see if it is below 30 V.  
It may result in a risk of electric shock.
- Only qualified persons should conduct maintenance and inspection. Take off metals (such as a watch and bracelet) before maintenance and inspection. Use a tool for insulation.  
Otherwise, electric shock or injury may occur.

#### ■ Items and contents of periodic inspection

Inspection item and target	Descriptions of inspection
Appearance of the inverter	Check that the vent hole or the heat sink does not get blocked with dust, and clean them.
Cooling fan	When dust is attached to the cooling fan, you should clean it. Replace the cooling fan, considering a service life time of about 20,000 hours as a guide. For cumulative operation time of the cooling fan, refer to {7.2 When [ALM] LED on Console Turns On}.
Inside the inverter	Inspect and check that dust is not attached to each board and electronic parts.
Terminal block and terminal screw	Inspect the terminal block and mounting screws for looseness, and retighten them.
Connector	Check connectors and terminals on the control board <VFC66-Z> for looseness.

Inspection item and target	Descriptions of inspection
Wiring	Check the insulating coating of the wiring for abnormalities such as cracks and deformation.
Main circuit capacitor	If it has any abnormalities such as electrolyte leakage or change of color, it should be replaced. For details, refer to {7.4 Inspecting and Replacing Main Circuit Capacitor}.

## 7.2 When [ALM] LED on Console Turns On

When cumulative operation time of the inverter exceeds a specified time, the [ALM] LED on the console turns on.

It indicates that the main circuit capacitor or the cooling fan reaches the guide of its life. Turning on the [ALM] LED will not limit operation of the inverter.

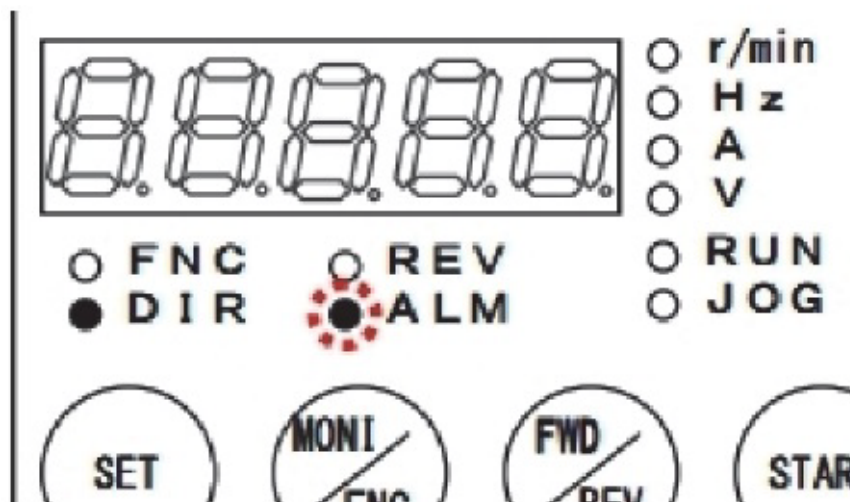

### ■ When to replace the main circuit capacitor and cooling fan

The inverter counts cumulative operation time in one hour.

You can check cumulative operation time by using the monitor item <tin>. At the same time, the remaining life of the main circuit capacitor and that of the cooling fan are displayed in the monitor items (timer remaining time 1 <tin1> and timer remaining time 2 <tin2>) as a guide.

When the [ALM] LED turns on, check these monitor items for remaining time.

For details of monitor items, refer to {4.1.6 Checking Operating State} and {4.1.7 List of Monitor Items}.

When a value of the timer remaining time 1 <tin1> becomes less than or equal to "0," this indicates that it is time to replace the main circuit capacitor and that replacement of the capacitor is recommended.



When a value of the timer remaining time 2 <tin2> becomes less than or equal to "0," this indicates that it is time to replace the cooling fan and that replacement of the fan is recommended.



For replacing the main circuit capacitor, refer to {7.4 Inspecting and Replacing Main Circuit Capacitor}. For replacing the cooling fan, refer to {7.3 How to Replace Cooling Fan}.

### ■ To turn off the [ALM] LED

To turn off the [ALM] LED which has been turned on, a setting of the timer remaining time should be cleared. Use <S-01> and <S-02>. For details, refer to {5.3.16 Area S}.

#### ■ Default setting of the cumulative operation timer

You can change a setting of cumulative operation time with the Cumulative\_operation\_timer(1) <F-04> and the Cumulative\_operation\_timer(2) <F-05>. In the initial state, they are set as follows:

- Cumulative\_operation\_timer(1) <F-04>: Guide of remaining life of the main circuit capacitor
- Cumulative\_operation\_timer(2) <F-05>: Guide of remaining life of the cooling fan

Each amount of time indicates a guide of remaining life, and it does not assure their behaviors.

For details of <F-04> and <F-05>, refer to {5.3.7 Area F}.

Initialized data of Cumulative\_operation\_timer(1) and Cumulative\_operation\_timer(2)

Cumulative_operation_timer(1) <F-04>	Cumulative_operation_timer(2) <F-05>
43800Hr	21900Hr

## 7.3 How to Replace Cooling Fan

This section describes how to replace the cooling fan.

The cooling fan is a component specific to each model of the inverter. For replacement, use a cooling fan the same as the one installed on the inverter.

For replaced parts of the cooling fan, contact us.



### WARNING Replaced parts

- Before conducting an inspection, turn off the input power supply and wait for ten or more minutes. Also, check that voltage between the direct-current terminals [+1] and [-] as well as [+2] and [-] on the main circuit terminal block is below 30 V.  
It may result in a risk of electric shock.
- Only qualified persons should conduct maintenance and inspection. Take off metals (such as a watch and bracelet) before maintenance and inspection. Use a tool for insulation.  
Otherwise, electric shock or injury may occur.



### CAUTION Precautions concerning handling

- Handle parts with care not to make a powerful impact.  
Deformation will cause a failure of the inverter.

### 7.3.1 How to Remove Cooling Fan

This section describes how to typically remove the cooling fan.

For the cooling fan, its shape, number of pieces, the presence or absence of screws, and its position depend on your inverter model.

Refer to the product catalog section on our web site (<https://www.toyodenki.co.jp/en/>) or contact us.



### CAUTION Removing the cooling fan

- When removing the cooling fan, be careful not to put a strain on the electrical wire.

1. Use the Phillips screwdriver to loosen screws of the mounting plate of the cooling fan.
2. Slide the mounting plate of the cooling fan to the front side.

Slide the mounting plate to the front side

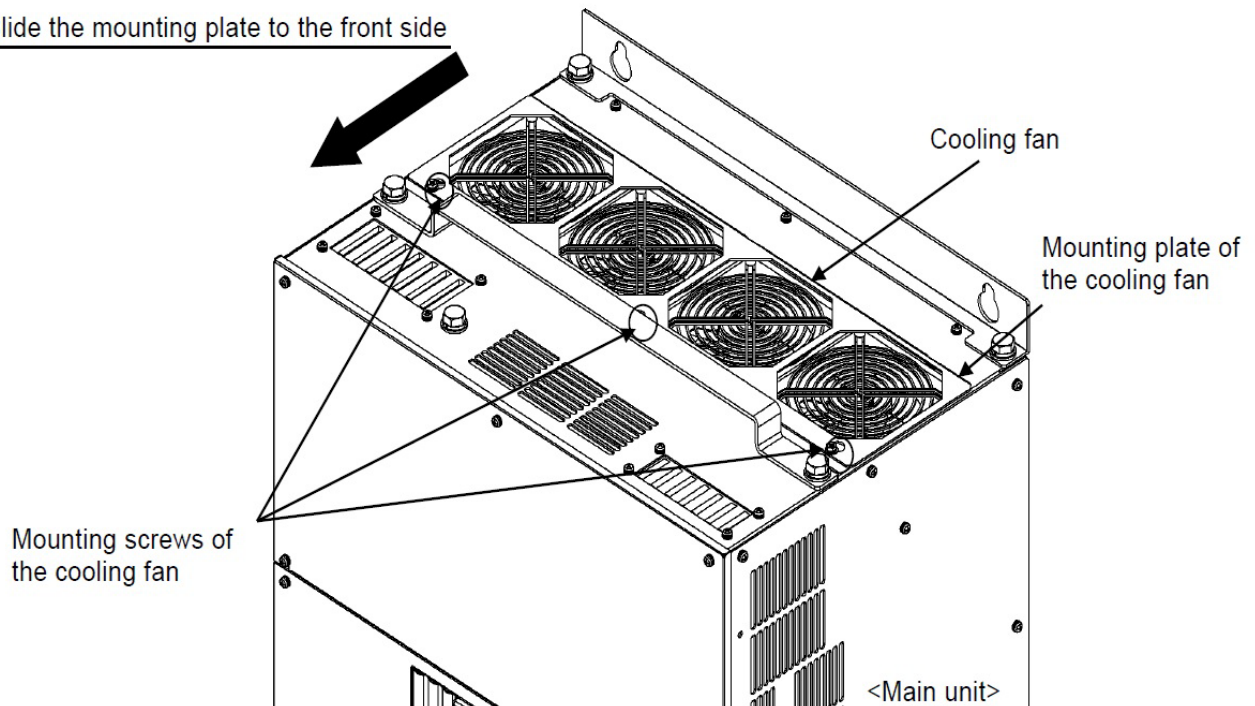

### 3. Incline and lift the plate.

- For some models, the plate is only to be unlocked (with no screw).

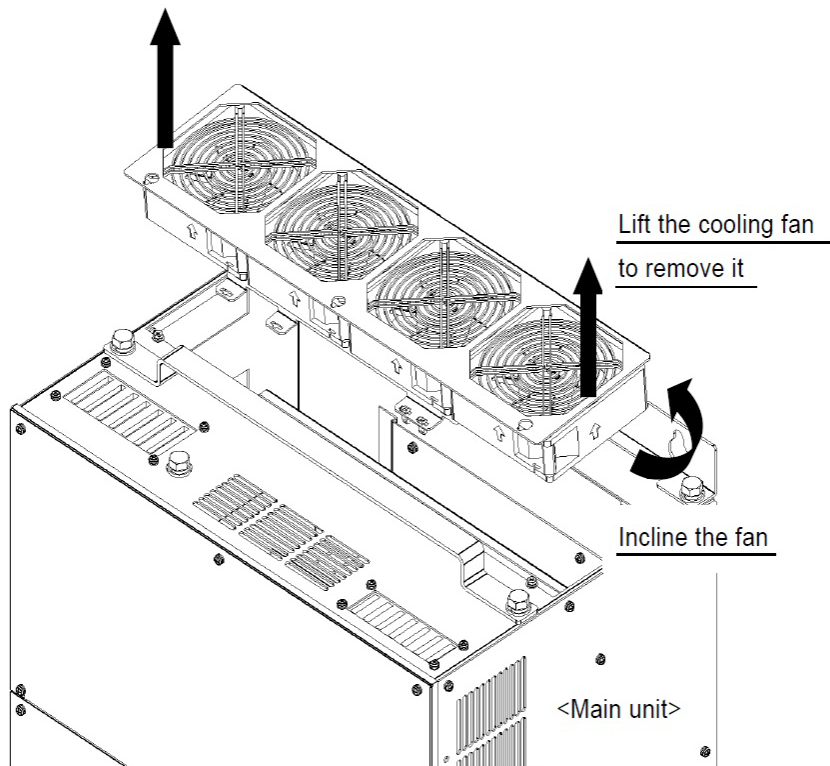

- 4. Pull out the connector of the electrical wire connected to the inverter main unit.
- 5. Remove the connector of the cooling fan from the connector mounting plate of the cooling fan.

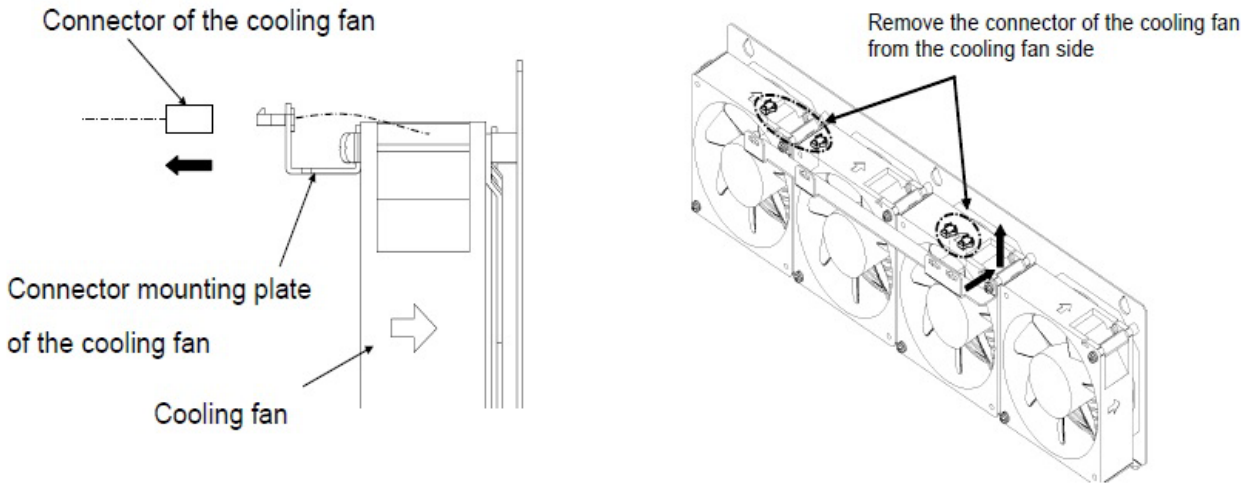

- 6. Use the Phillips screwdriver to remove screws, and remove the cooling fan from the plate.

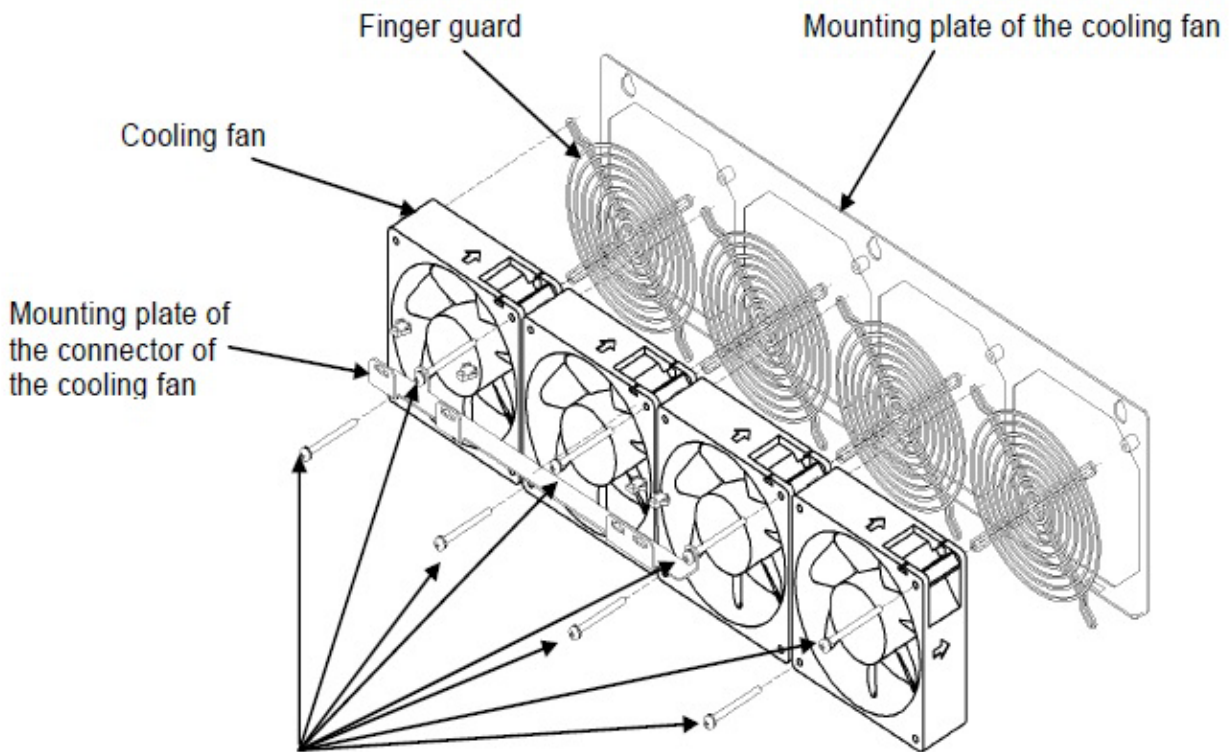

Use the Phillips screwdriver to remove the screws and then remove the cooling fan.

### 7.3.2 How to Install Cooling Fan

This section describes how to typically install the cooling fan.

For the cooling fan, its shape, number of pieces, the presence or absence of screws, and its position depend on your inverter model.

Refer to the product catalog section on our web site (<https://www.toyodenki.co.jp/en/>) or contact us.

#### CAUTION Installation of the cooling fan

- Care should be taken that the lead wire does not get struck between the cooling fan and the main unit.
- Do not bend the lead wire tightly. Push it softly.
- Incorrect directions of the wind and the wiring slot of the cooling fan will cause a failure. Check them carefully and then install it.

1. Follow the procedures described in {7.3.1 How to Remove Cooling Fan} in the reverse order to install each part.

2. Connect the connector of the cooling fan to the connector of the electrical wire on the main unit.  
 • For the pathway of the electrical wire of the cooling fan, put it in the state before the fan is removed.

3. Insert the mounting plate of the cooling fan so that the hole on the plate fits the claw on the chassis.

4. Use the Phillips screwdriver to tighten the screws of the mounting plate of the cooling fan.  
 • For some model, the plate is only locked with no screw.

Finally tighten the screws  
after checking that the plate is inserted.

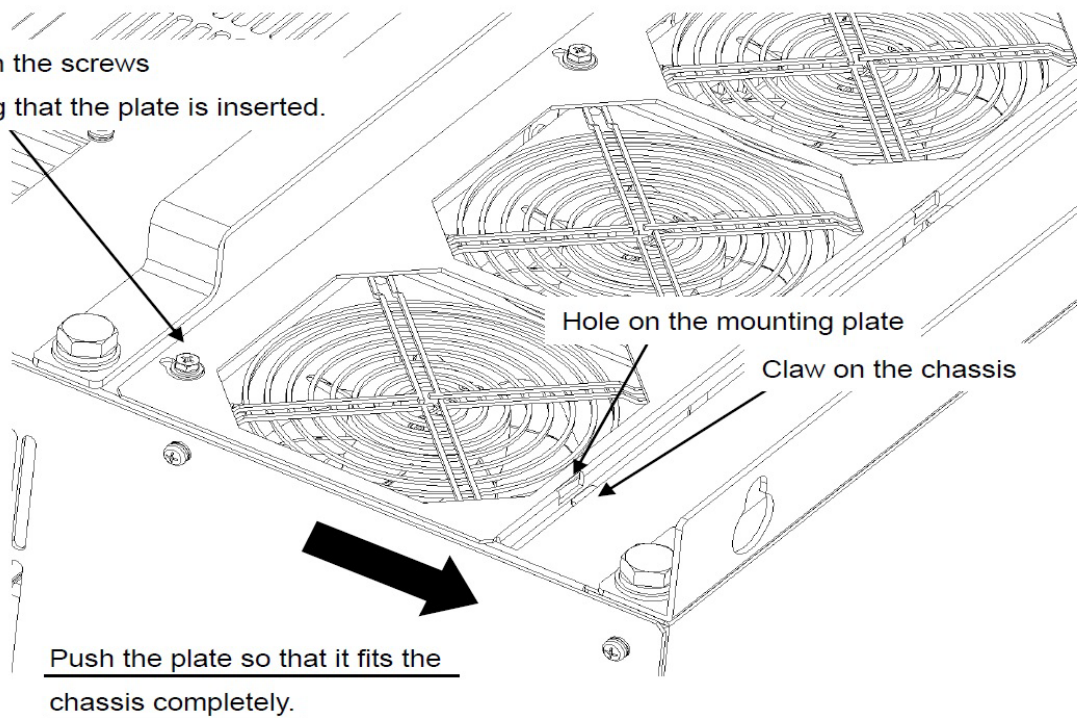

## 7.4 Inspecting and Replacing Main Circuit Capacitor

If any abnormalities of the main circuit capacitor (such as electrolyte leakage or change of color) are found in a periodic inspection, etc., you should contact us.

Also, when the [ALM] LED on the console turns on in this inverter, it indicates that the main circuit capacitor reaches the guide of its life. When a value of the timer remaining time 1 <tin1> becomes less than or equal to "0," the [ALM] LED turns on. It indicates that replacement of the main circuit capacitor is recommended. When the main circuit capacitor operates for 12 hours per day at the average ambient temperature of below 35 °C, it should be replaced in ten years as a guide.

### CAUTION Main circuit capacitor

- Before using the inverter which has been stored for two or more years as a spare, conduct aging of the main circuit capacitor. For aging, apply the rated input voltage to the inverter for about eight hours with the inverter output electrical wire removed.

If the capacitor is used without aging, it may be damaged, resulting in a dangerous situation.

## 7.5 How to Perform Insulation Resistance Test

When the board and the terminal block have been cleaned in a periodic inspection, etc., before operating the inverter, you should perform the insulation resistance test of the main circuit and check it for short-circuit.

Use a megger with 500 VDC to perform the insulation resistance test.

Do not perform the insulation resistance test of the control circuit.

Prepared items

- Phillips screwdriver (M3)
- Phillips screwdriver (M4)
- Megger with 500 VDC

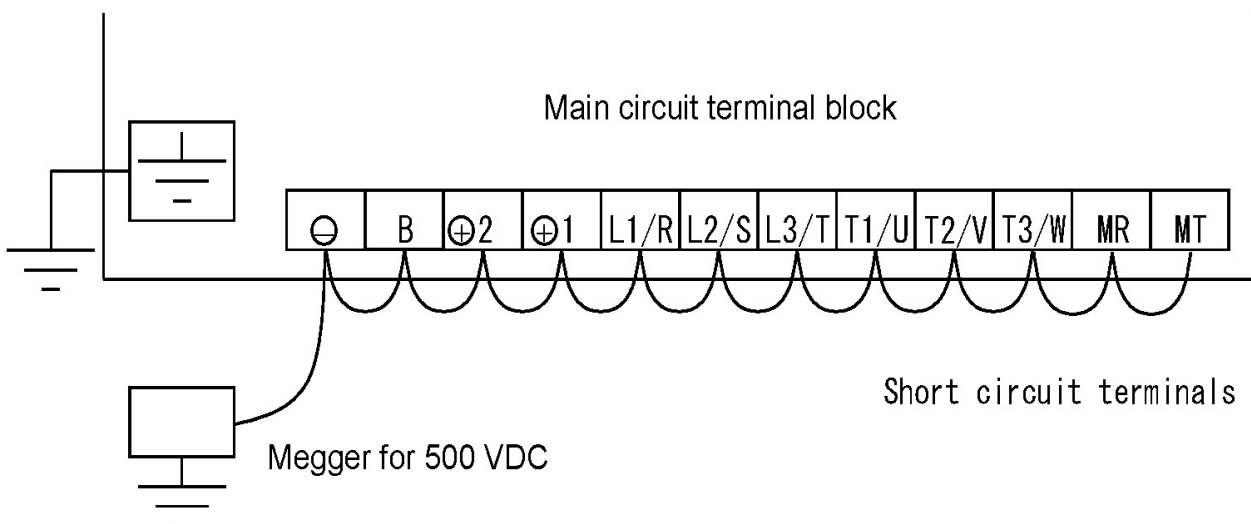

### 1. Turn off the inverter, and open the front cover.

- For how to open the front cover, refer to {3.2 How to Open and Close Front Cover}.
- Use the Phillips screwdriver (M4).

**2. Remove all wires.**

- Use the Phillips screwdriver (M3).

**3. Short circuit all terminals on the main circuit terminal block.**

- For the terminal block and the position of terminals, refer to {3.3.1 How to Connect Inverter Terminals}.

**4. Measure insulation resistance between the terminals on the main circuit terminal block and the protective earth terminal.**

- Check that insulation resistance is more than or equal to 10 M-ohm.
- If it is less than 10 M-ohm, contact us.

**5. Remove all short-circuit wires.****6. Return the wires to the original state.****7. Close the front cover.****7.6 How to Discard Parts**

To discard replaced parts or service parts, follow the instructions of each administrative agency.

## Chapter 8 Replacing Control Board

### 8.1 Tasks Required for Replacing Control Board

When the control board <VFC66-Z> has been replaced with a spare, the settings and adjustment below are required to adapt it to the inverter.

- Settings of the inverter capacity, rated motor (a value on the nameplate), and Autotuning data
- Gain adjustment of the analog circuit part

For settings of the rated motor (a value on the nameplate) and Autotuning data, refer to {4.3.2 Requirements for Performing Autotuning} and {5.3.2 Area A}.

### 8.2 How to Replace Control Board

This control board has different mounting methods depending on the model name. Check the board model name before installing the board with following procedure. As shown in the figure below, the board model name is silk-printed at the position.

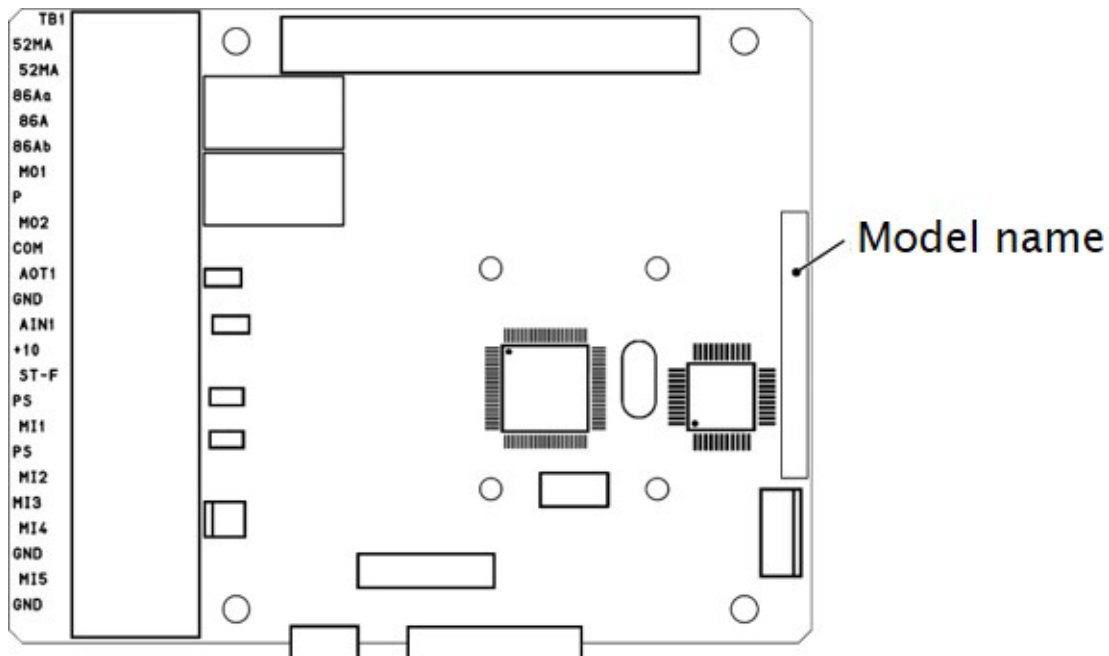

#### ■ For VFC66-Z-P1



### WARNING

Replacing the control board<VFC66-Z>

- Be sure to turn off the inverter when opening or closing the front cover, and then install the board. It may result in a risk of electric shock.

#### Prepared items

- Spare of the control board <VFC66-Z>
- Phillips screwdriver (M3)
- Phillips screwdriver (M4)
- Needle-nose plier

Open the front cover. The optional board is located in the front side, and the console board <SET66-Z> is

located above the control board <VFC66-Z> in the back.

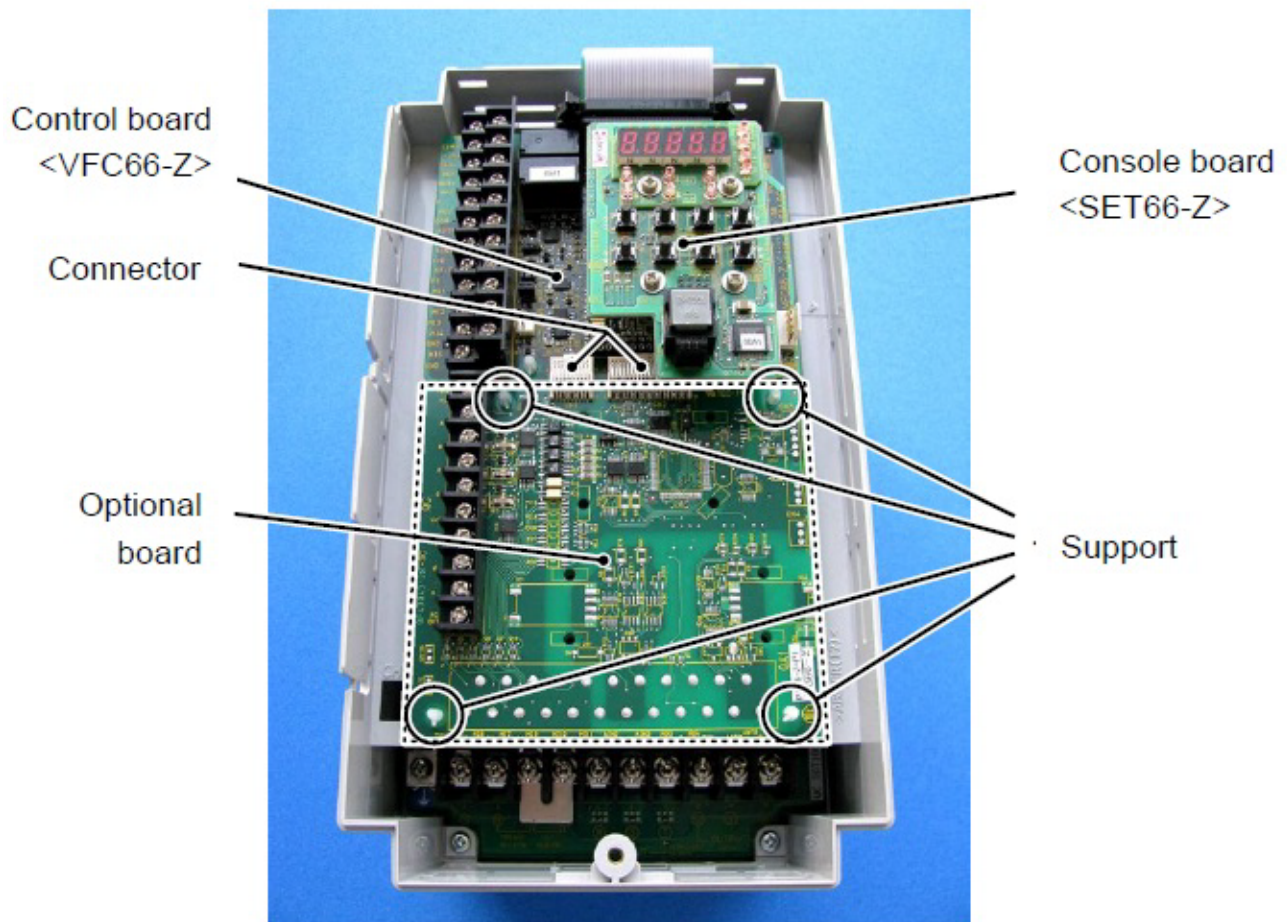

**1. Turn off the inverter.**

**2. Open the front cover.**

- For how to open the front cover, refer to {3.2 How to Open and Close Front Cover}.
- Use the Phillips screwdriver (M4).

**3. Remove four screws on the console board < SET66-Z>.**

- Use the Phillips screwdriver (M3).

**4. Remove the console board <SET66-Z>.**

- Pull out the console board from the control board < VFC66-Z> to remove it.

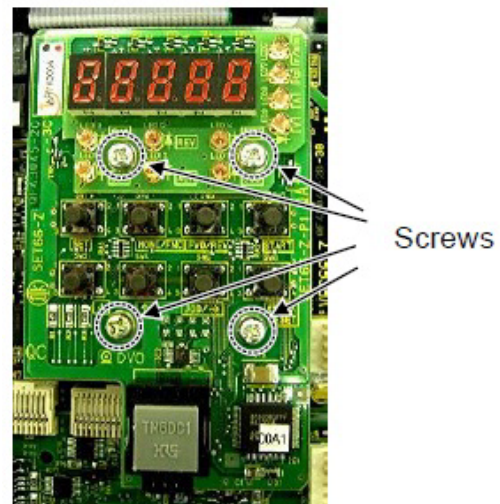

**5. Remove the joint of two connectors between the control board <VFC66-Z> and the optional board.**

- Push up the knob to remove the joint of the connectors.

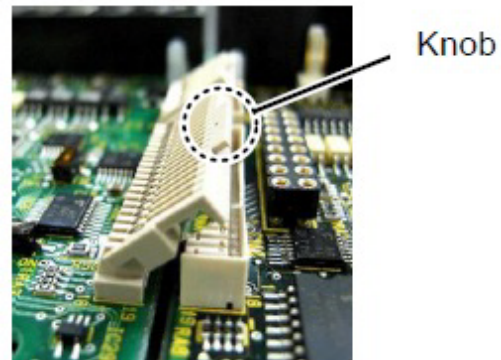

**6. Push four claws of the support holding the optional board into the support.**

- The support fixes the optional board to the chassis of the inverter.
- When having a difficulty in pushing the claws, use a needle-nose plier.

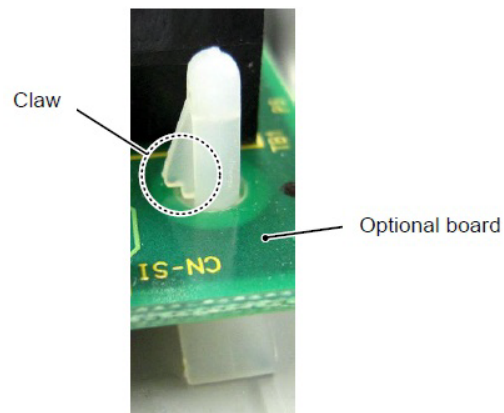

**7. Remove the optional board.**

**8. Remove the flat cable of the control board <VFC66-Z>.**

**9. Push four claws holding the control board <VFC66-Z> into the support.**

- The control board <VFC66-Z> is also fixed to the chassis of the inverter with the support.
- When having a difficulty in pushing the claws, use a needle-nose plier.

**10. Remove the console board <VFC66-Z>.**

**11. Align four holes on a new control board <VFC66-Z> to the support.**

12. Push the control board <VFC66-Z> until the claws of the support hang on the upper portion of the board.
13. Align the four holes on the removed optional board to the support.
14. Push the optional board until the claws of the support hang on the upper portion of the board.
15. Connect the flat cable of the control board <VFC66-Z>.
16. Push up the knobs of the connectors [CN1] and [CN2] on the optional board.
17. Fix the knobs of connectors [CN1] and [CN2] into the connectors [CN7] and [CN4] on the control board <VFC66-Z>.
  - The moving part of the connector is elastic. If it is not installed tightly, it may be removed. Fix it tightly.
18. Install the console board <SET66-Z> and then tighten four screws.
  - Use the Phillips screwdriver (M3).
19. Close the front cover of the inverter.
  - Use the Phillips screwdriver (M4).

■ For VFC66-Z-P2



## WARNING Replacing the control board <VFC66-Z>

- Be sure to turn off the inverter when opening or closing the front cover, and then install the board. It may result in a risk of electric shock.
- When connecting the control board and the optional board via the connector, make sure the pins are not misaligned. It may result in a risk of electric shock, injury, failure, or malfunction.



## CAUTION Installation / Removal of Control Board

- Do not repeatedly attach and detach the connector. Also, do not apply excessive force when attaching or detaching it. This may cause connector damage or poor connection.
- Do not insert anything other than the appropriate mating connector. Doing so may deform the connector and cause poor connection or other issues.

### Prepared items

- Spare of the control board <VFC66-Z>
- Phillips screwdriver (M3)
- Phillips screwdriver (M4)
- Needle-nose plier

Open the front cover. The optional board is located in the front side, and the console board <SET66-Z> is located above the control board <VFC66-Z> in the back.

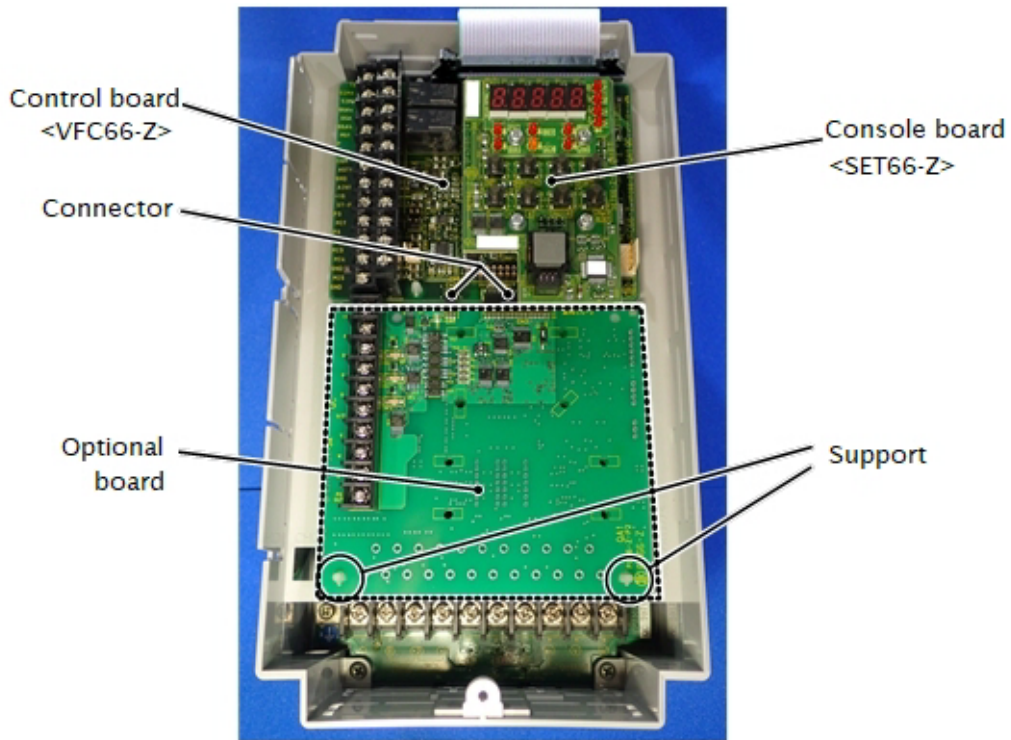

1. Turn off the inverter.
2. Open the front cover.
  - For how to open the front cover, refer to {3.2 How to Open and Close Front Cover}.
  - Use the Phillips screwdriver (M4).
3. Remove four screws on the console board < SET66-Z>.
  - Use the Phillips screwdriver (M3).
4. Remove the console board <SET66-Z>.
  - Pull out the console board from the control board < VFC66-Z> to remove it.

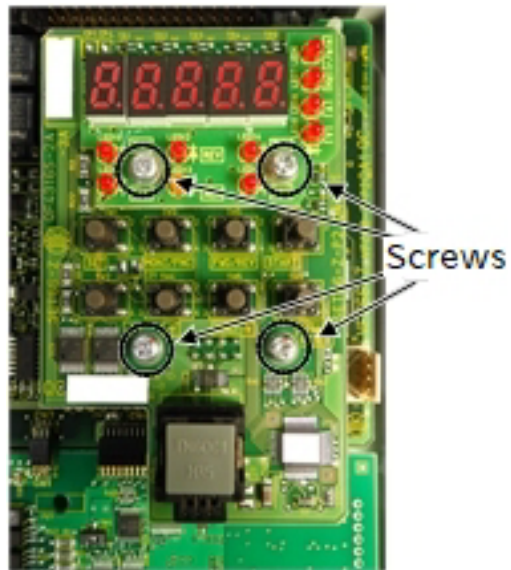

5. Push two claws of the support holding the optional board into the support.

- The support fixes the optional board to the chassis of the inverter.
- When having a difficulty in pushing the claws, use a needle-nose plier.

6. Release the support while lifting the bottom edge of the optional board.

- Do not lift the bottom edge of the optional board too much, the connectors could be damaged.

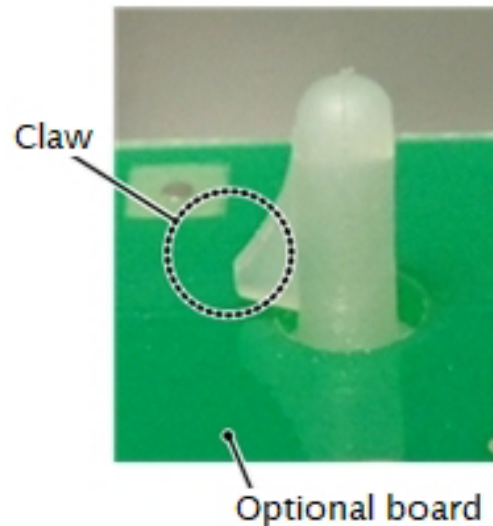

7. Remove the optional board.

- Lift the bottom edge of the optional board in the direction of "1" and pull the board away from the VFC66-Z in the direction of "2".

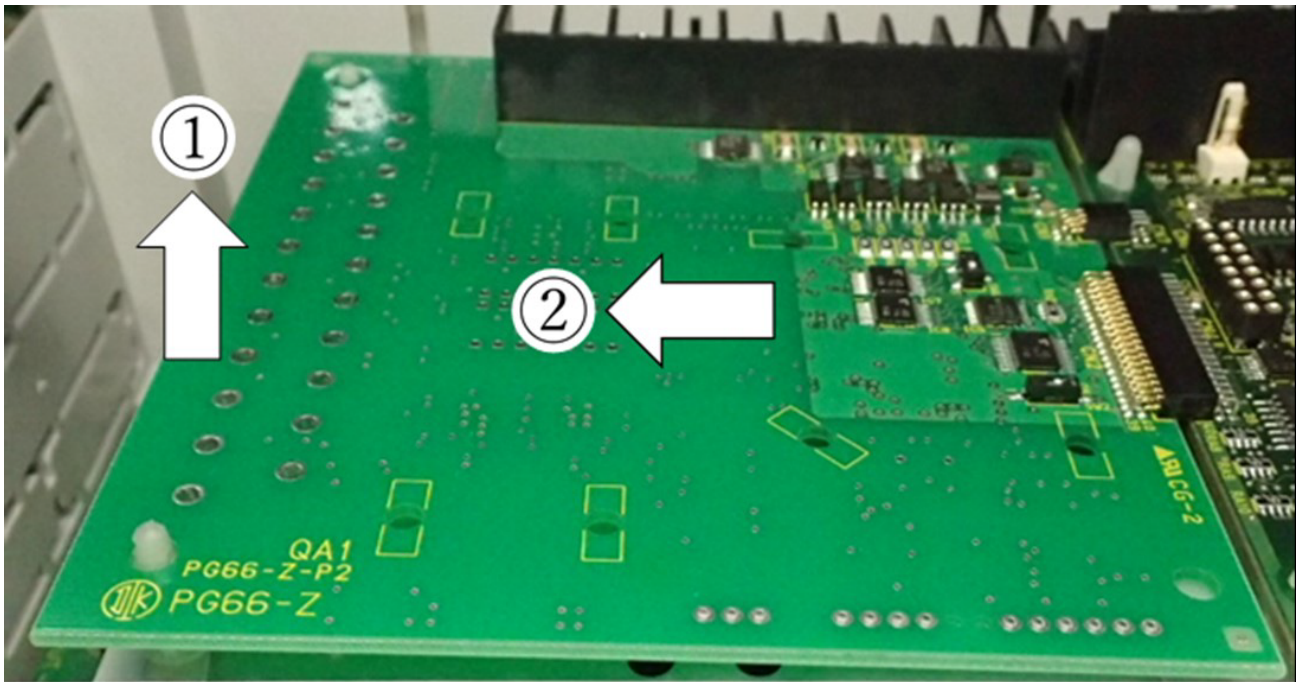

8. Remove the flat cable of the control board <VFC66-Z>.

9. Push four claws holding the control board <VFC66-Z> into the support.

- The control board <VFC66-Z> is also fixed to the chassis of the inverter with the support.
- When having a difficulty in pushing the claws, use a needle-nose plier.

10. Remove the console board <VFC66-Z>.

11. Align four holes on a new control board <VFC66-Z> to the support.

12. Push the control board <VFC66-Z> until the claws of the support hang on the upper portion of the board.

13. Align the pins of the optional board connectors CN1 and CN2 with the control board <VFC66-Z> connectors CN7 and CN4, push the optional board to engage with the connectors.

- If the connectors are not connected properly, there will be a gap between the connectors.

14. Push the control board <VFC66-Z> until the claws of the support hang on the upper portion of the board.

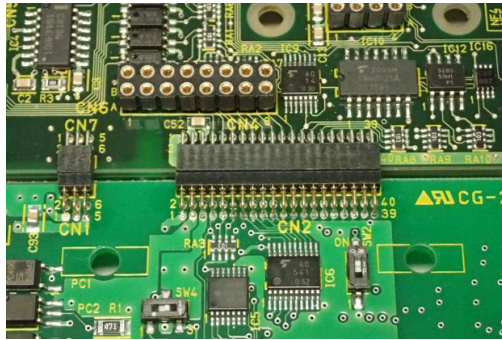

15. Connect the flat cable of the control board <VFC66-Z>.

16. Install the console board <SET66-Z> and then tighten four screws.

- Use the Phillips screwdriver (M3).

17. Close the front cover of the inverter.

- Use the Phillips screwdriver (M4).

### 8.3 How to Initialize Inverter Main Unit

You can set the inverter capacity by initializing the inverter.

Use the Special\_mode\_selection <S-00>.

For details of how to change parameter settings, refer to {4.1.3 Changing Parameter Settings}.

#### Initialization of the inverter main unit

Be sure to initialize the inverter main unit after replacing the control board <VFC66-Z>.

#### **WARNING** Safety notice

- High voltage is applied to a direct-current voltage meter or a tester. Experts should measure voltage.
- Close the front cover before turning on the power.  
It may result in a risk of electric shock.

#### **CAUTION** Safety notice

- To measure direct-current voltage, use a direct-current voltage meter or a tester which can measure 500 V or more for the 200 V class inverter and 1000 V or more for the 400 V class inverter.

#### Prepared items

- Phillips screwdriver (M3)
- Phillips screwdriver (M4)
- Direct-current voltage meter or tester

1. Turn off the inverter.
2. Open the front cover.
  - For how to open the front cover, refer to {3.2 How to Open and Close Front Cover}.
  - Use the Phillips screwdriver (M4).
3. Install a direct-current voltage meter or a tester between the direct-current terminals [+2] and [-] on the main circuit terminal block of the inverter.
  - For the terminal block and the position of terminals, refer to {3.3.1 How to Connect Inverter Terminals}.
4. Close the front cover and turn on the inverter.
5. When the [FNC] LED on the console turns off, press the [MONI/FNC] key.
  - The [FNC] LED turns on, and a setting item appears in the seven-segment display. For example, immediately after the inverter is turned on, the first item of the basic setting area is displayed.

**6. Press the keys [↑] and [↓] to display "S-00."**

- When the first item of the basic setting area is displayed, press the [↓] key once to display "S-00."
- For details of the Special\_mode\_selection <S-00>, refer to {5.3.16 Area S}.



**7. Press the [SET] key.**

- On the extreme right, "0" is displayed.
- The underscore blinks on the extreme left, which indicates that this becomes the operating digit.



**8. Press the [JOG/→] key to blink required digits, and then press the keys [↑] and [↓] to specify numbers to become "1040."**

- "1040" is a password. It is required to use the Special\_mode\_selection <S-00>.



**9. Press the [SET] key.**

- The password input is confirmed, and "S-00" is displayed again.
- When a different number from "1040" is input, "P-Err" indicating an error is displayed. In this case, press the keys [↑] and [↓] to return to "S-00." Follow the procedures again from the step 7.
- Here, you can stop the initialization by pressing the [STOP/RESET] key.



When an error occurs due to incorrect password input

**10. Press the [SET] key.**

- Again, "0" is displayed on the extreme right, and the underscore blinks on the extreme left.

**11. Press the [JOG/→] key to blink a required digit, and then press the keys [↑] and [↓] to change the number to "1" (Initialize the inverter).**

- The display of the setting value automatically returns to that of the setting item in ten seconds. Unless a setting value is specified while it is displayed, it cannot be changed.
- The change is confirmed, and then a message of "rEtun to FActory SEttinG" is displayed in turn.
- Then, "SurE" blinks.
- Here, you can stop the initialization by pressing the [STOP/RESET] key.



**12. Press the [SET] key.**

- The inverter series name is displayed.

When the inverter series name "VF66B" is displayed

**13. Use the keys [↑] and [↓] to display a desired inverter model, and then press the [SET] key.**

- The inverter capacity is displayed.

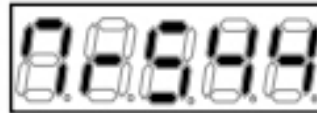

"7r5" shows a capacity of 7.5 kW, and "44" shows a 440 V class.

**14. Use the keys [↑] and [↓] to display a desired inverter capacity, and then press the [SET] key.**

- The inverter control method of the first setting block is selected and displayed.
- "o": [V/f control]
- "V": [Induction motor vector control]
- "E": [ED motor vector control]



As the inverter control method of the first setting block, "o" ([V/f control]) is displayed.

**15. Use the keys [↑] and [↓] to change the inverter control method of the first setting block, and press the [SET] key.**

- The inverter control method of the second setting block is selected and displayed.

**16. Similarly, use the keys [↑] and [↓] to change the inverter control method of the second setting block, and press the [SET] key.**

- Direct-current voltage is displayed.



17. Press the [JOG/→] key to blink required digits, press the keys [↑] and [↓] to change numbers to a value measured by the voltage meter or the tester, and then press the [SET] key.

- Since the software version No.02-A1, this is displayed.



- "init" is displayed for a few seconds, and then "End" is displayed. Now the initialization of the inverter is completed.



- About five seconds later, the inverter series name is displayed.
- Then, contents similar to what are displayed at power-on are displayed. Refer to {4.1.2 What Are Displayed at Power-on}.
- Then, a monitor item is displayed for about one second, and its data is displayed.



18. Turn off the inverter, and open the front cover.

19. Remove the installed direct-current voltage meter or tester.

20. Close the front cover.

## 8.4 How to Adjust Analog Input Gain

Here, set the two parameters <L-01> and <L-02> to adjust analog input gain.

For details of the Analog\_input(1)\_gain <L-01> and the Analog\_input(1)\_offset <L-02>, refer to {5.3.12 Area L}. This section describes how to use an auto adjustment function provided by the inverter to specify values of <L-01> and <L-02>, rather than manually and directly specifying them.

Use the Analog\_frequency\_command\_characteristic\_selection/Analog\_speed\_command\_characteristic\_selection <b-17> and the Analog\_input(1)\_adjustment <S-06>.

For details of the Analog\_frequency\_command\_characteristic\_selection/Analog\_speed\_command\_characteristic\_selection <b-17>, refer to {5.3.3 Area b}. For details of the Analog\_input(1)\_adjustment <S-06>, refer to {5.3.16 Area S}.

Also, for details of how to change parameter settings, refer to {4.1.3 Changing Parameter Settings}.

### Analog input gain adjustment

Be sure to adjust analog input gain after replacing the control board <VFC66-Z>.



### WARNING Short-circuit of terminals

- Be sure to turn off the inverter before short-circuit of terminals.  
It may result in a risk of electric shock.



### CAUTION Measuring voltage between terminals

- Great care must be taken not to touch electrical wires and terminals when measuring voltage between terminals.  
It may result in a risk of electric shock.

Prepared items

- Phillips screwdriver (M3)
- Phillips screwdriver (M4)
- Direct-current voltage meter or tester

1. When the [FNC] LED on the console turns off, press the [MONI/FNC] key.

- The [FNC] LED turns on, and a setting item appears in the seven-segment display. For example, immediately after the inverter is turned on, the first item of the basic setting area is displayed.

2. Press the keys [↑] and [↓] to display "b-00."



**3. Press the [JOG/→] key to blink numbers, and then press the keys [↑] and [↓] to change them to become "b-17."**

- For details of the Analog\_frequency\_command\_characteristic\_selection/Analog\_speed\_command\_characteristic\_selection <b-17>, refer to {5.3.3 Area b}.



**4. Press the [SET] key.**

- The selection of "b-17" is confirmed, a current setting value (Initialized data is "1") is displayed.
- The display of the setting value automatically returns to that of the setting item in ten seconds. Unless a setting value is specified while it is displayed, it cannot be changed.



**5. Press the keys [↑] and [↓] to change the number to "0" (0 to ±10 V).**



**6. Press the [SET] key.**

- The change is confirmed, and "b-17" is displayed again.
- The display of the setting value automatically returns to that of the setting item in ten seconds. Unless the [SET] key is pressed while a setting value is displayed, the change cannot be confirmed.



7. Turn off the inverter.

8. Open the front cover.

- For how to open the front cover, refer to {3.2 How to Open and Close Front Cover}.
- Use the Phillips screwdriver (M4).

9. Short circuit the terminals [AIN1] and [GND] on the control board <VFC66-Z>.

- For the terminal block and the position of terminals, refer to {3.3.1 How to Connect Inverter Terminals}.
- Use the Phillips screwdriver (M3).

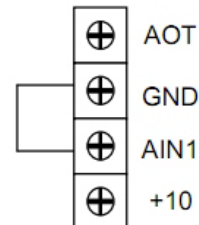

10. Close the front cover and turn on the inverter.

11. Press the [MONI/FNC] key.

- The [FNC] LED turns on, and a setting item appears in the seven-segment display. For example, immediately after the inverter is turned on, the first item of the basic setting area is displayed.

12. Press the keys [↑] and [↓] to display "S-00."



13. Press the [JOG/→] key to blink numbers, and then press the keys [↑] and [↓] to change them to become "S-06."

- For details of the Analog\_input(1)\_adjustment <S-06>, refer to {5.3.16 Area S}.



**14. Press the [SET] key.**

- On the extreme right, "0" is displayed.
- The underscore blinks on the extreme left, which indicates that this becomes the operating digit.

**15. Press the [JOG/→] key to blink required digits, and then press the keys [↑] and [↓] to specify numbers to become "1040."**

- "1040" is a password. It is required to use <S-06 >.

**16. Press the [SET] key.**

- The password input is confirmed, and "S-06" is displayed again.
- When a different number from "1040" is input, "P-Err" indicating an error is displayed. In this case, press the keys [↑] and [↓] to return to "S-06." Follow the procedures again from the step 14.



When an error occurs due to incorrect password input

**17. Press the [SET] key.**

- Again, "0" is displayed on the extreme right, and the underscore blinks on the extreme left.



**18. Press the [JOG/→] key to blink a required digit, and then press the keys [↑] and [↓] to change the number to "1."**

- The display of the setting value automatically returns to that of the setting item in ten seconds. Unless a setting value is specified while it is displayed, it cannot be changed.



**19. Press the [SET] key.**

- The change is confirmed, and "S-06" is displayed again.
- The display of the setting value automatically returns to that of the setting item in ten seconds. Unless the [SET] key is pressed while a setting value is displayed, it is not confirmed.



**20. Turn off the inverter, and open the front cover.**

**21. Remove the short-circuit wire between the terminals [AIN1] and [GND].**

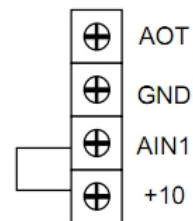

**22. Short circuit the terminals [AIN1] and [+10].**

**23. Install the direct-current voltage meter or the tester between the terminals [AIN1] and [GND].**

**24. Close the front cover and turn on the inverter.**

**25. Press the [MONI/FNC] key.**

- The [FNC] LED turns on, and a setting item appears in the seven-segment display. For example, immediately after the inverter is turned on, the first item of the basic setting area is displayed.

26. Press the keys [↑] and [↓] to display "S-00."



27. Press the [JOG/→] key to blink numbers, and then press the keys [↑] and [↓] to change them to become "S-06."



28. Press the [SET] key.

- On the extreme right, "0" is displayed, and the underscore blinks on the extreme left.



29. Press the [JOG/→] key to blink required digits, and then press the keys [↑] and [↓] to specify numbers to become "1040."



30. Press the [SET] key.

- The password input is confirmed, and "S-06" is displayed again.
- When a different number from "1040" is input, "P-Err" indicating an error is displayed. In this case, press the keys [↑] and [↓] to return to "S-06." Follow the procedures again from the step 28.



When an error occurs due to incorrect password input

**31. Press the [SET] key.**

- Again, "0" is displayed on the extreme right, and the underscore blinks on the extreme left.

**32. Press the [JOG/→] key to blink required digits, and then press the keys [↑] and [↓] to specify a value 1000 times a value measured by the voltage meter or the tester.**

- When it cannot be measured, "9930" should be specified. In this case, however, accuracy will be decreased.

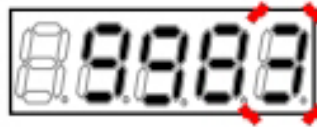
**33. Press the [SET] key.**

- When "S-06" is displayed again, the settings of the parameters <L-01> and <L-02> are automatically changed.

**34. Press the [MONI/FNC] key.**

- The [FNC] LED turns off, after a monitor item is displayed for about one second, its data appears.

**35. Turn off the inverter, and open the front cover.****36. Remove the short-circuit wire between the terminals [AIN1] and [+10].****37. Remove the installed direct-current voltage meter or tester.****38. Close the front cover.**

## Chapter 9 Standard Specifications

### 9.1 Common Specifications

The table below lists the common specifications of the inverter.

Capacity range	200 V class	2.2 kW, 3.7 kW, 5.5 kW, 7.5 kW, 11 kW, 15 kW, 22 kW, 30 kW, 37 kW, 45 kW, 55 kW, 75 kW, 90 kW
		(Parallel) 150 kW, 180 kW
	400 V class	2.2 kW, 3.7 kW, 5.5 kW, 7.5 kW, 11 kW, 15 kW, 22 kW, 30 kW, 37 kW, 45 kW, 55 kW, 75 kW, 110 kW, 160 kW, 200 kW, 250 kW, 315 kW
		(Parallel) 400 kW, 500 kW, 600 kW, 750 kW, 1000 kW
Rated power supply and variation	200 V class	200 to 220 V $\pm$ 10 %, 50/60 Hz
	400 V class	380 to 460 V $\pm$ 10 %, 50/60 Hz
Overload rated current		150 % (60 seconds), 200 % (three seconds). However, for models over 75 kW, it is limited to 150 % (60 seconds).

Control specifications	Control method	Induction motor			ED motor	
		V/f control	Vector control without speed sensor <sup>(1)</sup>	Vector control with speed sensor	Vector control without position speed sensor	Vector control with position speed sensor
Output frequency range		0.1 to 400.0 Hz			0 to 400.0 Hz	
Start torque (When our motor is used at cool temperature)		–	200 %	200 %	150 %	200 %
Speed control range (When our motor is used)		–	1:150	1:1000	1:100	1:1000
Torque limit	Powering/regenerative range: 0 to 200 %	Forward powering/forward regenerative/reverse powering/reverse regenerative range: 0 to 200 % for each				
Torque control	No	Yes				
PWM carrier frequency	1 to 6 kHz					
Acceleration or deceleration time	0.1 to 3600.0 seconds (pitch 0.1 second)					
Other operation functions	<p>JOG, S-pattern acceleration or deceleration, speed/frequency jump, droop control, regeneration stall prevention, instantaneous power interruption restart, DC brake, rotation direction change, Autotuning, protection retry, cooling fan "ON"/"OFF" function, cumulative operation timer</p> <p>For only [V/f]: Torque boost, stabilizer, V/f characteristics (V/f constant, square reduction, polygonal line)</p> <p>For only [IM]: Initial excitation</p>					

Input signal	Analog input	Number of inputs: 1ch as a standard, up to 2ch as an option, 2ch as an external option. However, for a standard 1ch and optional 1ch, 4 to 20 mA can be input. 0 to 10 V, $\pm 10$ V, 4 to 20 mA
	Digital input (option)	ProfiBus, CC-Link, DeviceNet, OPCN-1, RS-485 (Modbus RTU), EtherNet/IP
	Speed/frequency command	0 to 10 V or $\pm 10$ V (Maximum speed/10 V, maximum frequency/10 V) 4 to 20 mA (Maximum speed/20 mA, maximum frequency/20 mA) $\pm 20000$ digit when the communication option is used (Maximum speed/20000 digit, maximum frequency/20000 digit)
	Torque command	0 to $\pm 10$ V (150 %/-10 V) $\pm 10000$ digit when the communication option is used (150 %/7500 digit)
	Terminal block input	The Sink mode / Source mode can be changed.
	Fixed function terminal	One contact: Forward operation command
	Function terminal	Number of inputs: Five as a standard, six as an option, six as an external option Input item: Preset speed/frequency command (seven), acceleration or deceleration time selection (four types), MRH mode operation, speed/frequency hold, S-pattern acceleration or deceleration prohibition, maximum speed/maximum frequency reduction, droop control disabled, torque control selection, DC brake command, initial excitation command, external failure signal (four contacts), traceback external trigger, second setting block selection, emergency stop (Normally close), speed/frequency command terminal block selection, reverse operation command, forward JOG command, reverse JOG command, emergency stop (Normally open), protection reset
Output signal	Output for speed/frequency meter	PWM pulse six times the speed output frequency The analog meter can be connected. However, it cannot be used with standard analog output at the same time.
	Analog monitor output	Number of outputs: 1ch as a standard, 2ch as an option. However, for an optional 1ch, 4 to 20 mA can be output. 0 to $\pm 10$ V, 4 to 20 mA Output item: Output voltage, output current, output torque, speed/output frequency, speed command/frequency command, internal PLC output, and others
	Function terminal	Number of outputs: Two as a standard, two as an option, two as an external option Open collector output Output item: Speed/frequency detection (two), setting reached, torque detection (two types: with pole and absolute value), during power failure, overload pre-alarm, during retry, in reverse operation, protection operation code, in operation, timer 1 elapsed, timer 2 elapsed, second setting block being selected, failed fan motor, DB abnormal state

Internal PLC	Program capacity	16 kB, about 1024 steps <ul style="list-style-type: none"> <li>However, to edit contents of the internal PLC, the personal computer tool is required.</li> </ul>
	Sequence	Input: Five as a standard, 12 as an option, communication input from the superior CPU (option)  Output: Open collector (two as a standard, four as an option), contact output (1 normally open, 1 change over), communication output to the superior CPU (option)  Types of internal relay: Input relay, output relay, on-timer relay, off-timer relay, and others  Command: Normally open, normally close, and change over  Function: About 30 types including inversion, addition, subtraction, multiplication, division, and remainder
	Function (super-block)	About 15 types including PI control and speed control
Item displayed on the console	Output frequency, speed, speed/frequency setting, output current, output torque, direct-current voltage, input/output terminal check, protection history, and others	
Protection function	Overcurrent, direct-current part overvoltage, insufficient voltage, overspeed/over-frequency, overtorque, inverter overheat, motor overheat, charging resistance overheat, overload, IGBT protection operation, memory abnormality, current sensor abnormality, startup stall, communication timeout error, speed control error, FCL operation, and others	
Personal computer tool	Console Dataset (parameter setting), Control Block Editor (internal PLC edition), VF Monitor (operation and protection monitor)	
Environmental condition	Operating temperature: 0 to 50 °C Humidity: 20 to 90 %RH (no condensation) Altitude: 1000 m or less Storage temperature: -20 to 60 °C Atmosphere: No plasticizer such as corrosive gas, metallic powder, oil, halogen, and DOP should be contained. Vibration: 5.9 m/s <sup>2</sup> (0.6 G or less, 10 to 55 Hz). Comply with JIS C60068-2-6. Under an environment below the overvoltage category III defined by IEC60664-1 and below the pollution degree 2.	
Unit protective structure	IP00 (JIS C 0920): Open-type structure, not especially consider a protection against human bodies, a protection against invasion of solid objects, and a protection against invasion of water.	
Compatible standards	IEC/EN 61800-5-1:2007 (Low Voltage Directive), EN55011 Group1 ClassA (EMC Directive), IEC/EN61800-3 C3 (EMC Directive)	

(1) In vector control without speed sensor, sufficient torque may not be obtained during regeneration.

## 9.2 List of Capacity

The tables below list the capacity for each inverter model.

The applied motor capacity shows a typical motor capacity. The input power factor and input capacity show values when the applied rated motor is output, depending on power supply impedance.

For the models below, the direct-current reactor (DCL) is an option.

- 200 V class: <2R222> through <5522>
- 400 V class: <2R244> through <5544>

### ■ 200 V class

Inverter model		2R222	3R722	5R522	7R522	1122	1522	2222
Applied motor capacity [kW]		2.2	3.7	5.5	7.5	11	15	22
Rated output current [A]		10	17	24	32.5	46	62.5	87
Maximum output voltage [V]		200 to 220 V (corresponding to input voltage)						
Input voltage [V]		Three-phase three-wire 200 to 220 V $\pm$ 10 % 50/60 Hz						
Input power factor		Delay about 0.7 (When DCL is connected: About 0.9)						
Input capacity [kVA]	Without DCL	4.95	8.4	12.1	16.6	23.3	31.8	45.5
	With DCL	3.54	5.85	8.74	11.7	16.4	22.4	32.5
Rated input current [A]	Without DCL	14.3	24.2	34.9	47.9	67.3	91.8	131
	With DCL	10.2	16.9	25.2	33.7	47.3	64.7	93.8
DCL		DCL3R722	DCL3R722	DCL7R522	DCL7R522	DCL1122	DCL1522	DCL2222
Cooling method		Forcible cooling						
Weight [kg]		3.3	3.3	5.5	5.5	16	16	24

Inverter model		3022	3722	4522	5522	7522	9022
Applied motor capacity [kW]		30	37	45	55	75	90
Rated output current [A]		121	146	185	222	280	340
Maximum output voltage [V]		200 to 220 V (corresponding to input voltage)					
Input voltage [V]		Three-phase three-wire 200 to 220 V $\pm$ 10 % 50/60 Hz					
Input power factor		Delay about 0.7 (When DCL is connected: About 0.9)					
Input capacity [kVA]	Without DCL	61.9	76.4	92	112	—	—
	With DCL	43.6	53.7	65.6	80.1	108	130
Rated input current [A]	Without DCL	179	221	266	323	—	—
	With DCL	126	155	189	231	312	375
DCL		DCL3022	DCL3722	DCL4522	DCL5522	DCL7522	DCL9022
Cooling method		Forcible cooling					
Weight [kg]		35	38	52	55	73	94

## Parallel model

Inverter model		15022	18022
Applied motor capacity [kW]		150	180
Rated output current [A]		560	680
Maximum output voltage [V]		200 to 220 V (corresponding to input voltage)	
Input voltage [V]		Three-phase three-wire 200 to 220 V $\pm$ 10 % 50/60 Hz	
Input power factor		Delay about 0.7 (When DCL is connected: About 0.9)	
Input capacity [kVA]	Without DCL	—	—
	With DCL	214	257
Rated input current [A]	Without DCL	—	—
	With DCL	618	742
DCL		DCL7522 x 2	DCL9022 x 2
Cooling method		Forcible cooling	
Weight [kg]		73 x 2	94 x 2

## ■ 400 V class

Inverter model		2R244	3R744	5R544	7R544	1144	1544	2244
Applied motor capacity [kW]		2.2	3.7	5.5	7.5	11	15	22
Rated output current [A]		5.5	9.2	13	17	24	32.5	46
Maximum output voltage [V]		380 to 460 V (corresponding to input voltage)						
Input voltage [V]		Three-phase three-wire 380 to 460 V $\pm$ 10 % 50/60 Hz						
Input power factor		Delay about 0.7 (When DCL is connected: About 0.9)						
Input ca- pacity [kVA]	Without DCL	4.95	8.36	11.9	16.3	23.2	31.7	45.4
	With DCL	3.55	5.89	8.61	11.5	16.8	22.5	31.8
Rated input current [A]	Without DCL	7.14	12.1	17.2	23.5	33.5	45.8	65.5
	With DCL	5.12	8.5	12.4	16.6	24.2	32.5	45.9
DCL		DCL3R744	DCL3R744	DCL7R544	DCL7R544	DCL1544	DCL1544	DCL2244
Cooling method		Forcible cooling						
Weight [kg]		3.3	3.3	5.4	5.4	16	16	22

Inverter model		3044	3744	4544	5544	7544	11044	16044
Applied motor capacity [kW]		30	37	45	55	75	110	160
Rated output current [A]		62.5	75.5	92.5	111	146	210	300
Maximum output voltage [V]		380 to 460 V (corresponding to input voltage)						
Input voltage [V]		Three-phase three-wire 380 to 460 V $\pm$ 10 % 50/60 Hz						
Input power factor		Delay about 0.7 (When DCL is connected: About 0.9)						
Input ca- pacity [kVA]	Without DCL	61.8	76.2	91.2	111	—	—	—
	With DCL	43.9	54.1	64.7	79	107	157	225
Rated input current [A]	Without DCL	89.2	110	132	160	—	—	—
	With DCL	63.4	78.1	93.4	114	154	227	324
DCL		DCL3044	DCL3744	DCL4544	DCL5544	DCL7544	DCL11044	DCL16044
Cooling method		Forcible cooling						
Weight [kg]		32	34	47	50	63	79	100

Inverter model		20044	25044	31544
Applied motor capacity [kW]		200	250	315
Rated output current [A]		370	460	600
Maximum output voltage [V]		380 to 460 V (corresponding to input voltage)		
Input voltage [V]		Three-phase three-wire 380 to 460 V $\pm 10\%$ 50/60 Hz		
Input power factor		Delay about 0.7 (When DCL is connected: About 0.9)		
Input capacity [kVA]	Without DCL	—	—	—
	With DCL	281	348	439
Rated input current [A]	Without DCL	—	—	—
	With DCL	406	502	634
DCL		DCL20044	DCL25044	DCL31544
Cooling method		Forcible cooling		
Weight [kg]		182	193	281

## Parallel model

Inverter model		40044	50044	60044	75044	100044
Applied motor capacity [kW]		400	500	600	750	1000
Rated output current [A]		740	920	1110	1380	1840
Maximum output voltage [V]		380 to 460V (corresponding to input voltage)				
Input voltage [V]		Three-phase three-wire 380 to 460 V $\pm 10\%$ 50/60 Hz				
Input power factor		Delay about 0.7 (When DCL is connected: About 0.9)				
Input capacity [kVA]	Without DCL	—	—	—	—	—
	With DCL	557	696	836	1046	1394
Rated input current [A]	Without DCL	—	—	—	—	—
	With DCL	804	1005	1207	1510	2012
DCL		DCL20044 x 2	DCL25044 x 2	DCL20044 x 3	DCL25044 x 3	DCL25044 x 4
Cooling method		Forcible cooling				
Weight [kg]		182 x 2	193 x 2	182 x 3	193 x 3	193 x 4

## Chapter 10 Outline Drawing of Inverter

### 10.1 Standard Type

For the outline, the standard type is divided into a small type and large type depending on the capacity.

#### ■ Small type

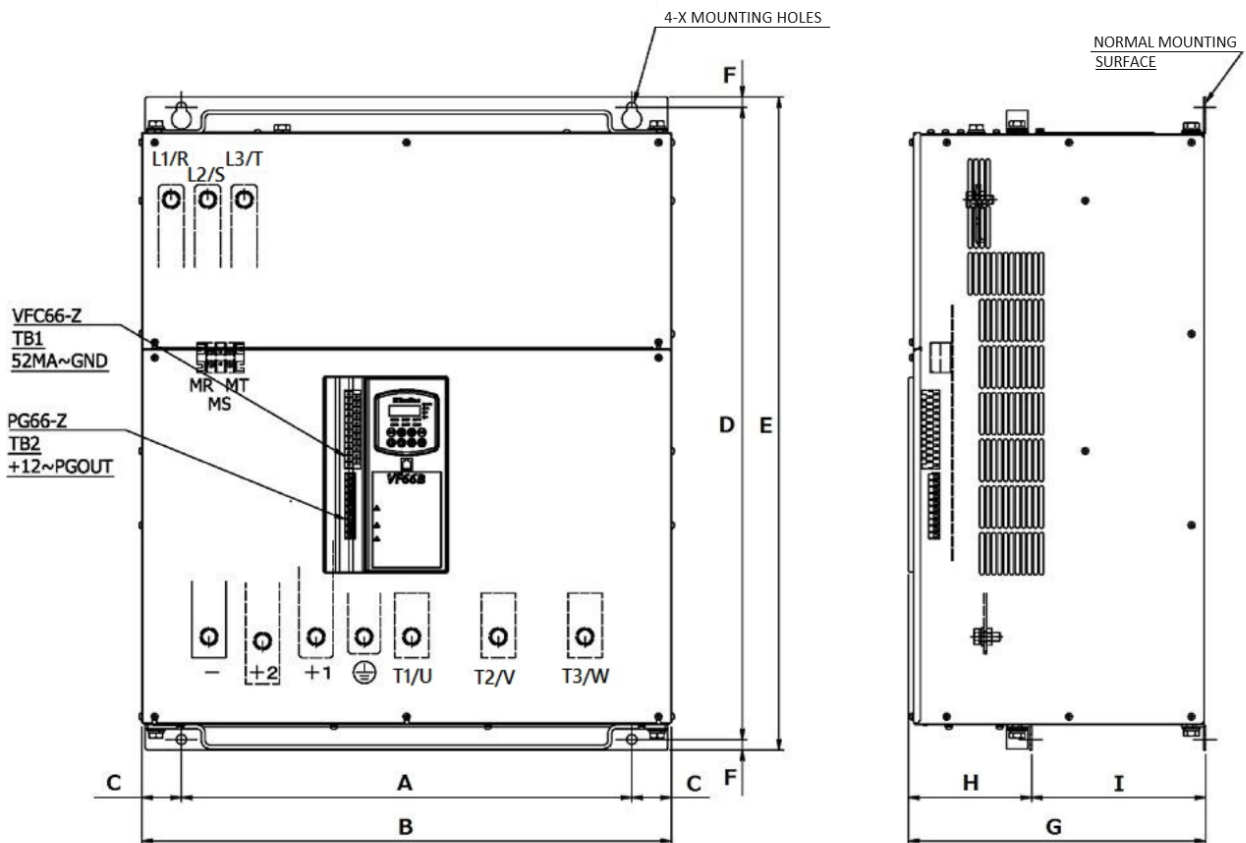

Inverter model		Dimension (Unit: mm)									Screw size
200 V class	400 V class	A	B	C	D	E	F	G	H	I	X
2R222	2R244	130	150	10	250	265	7.5	195	-	-	M5
3R722	3R744	130	150	10	250	265	7.5	195	-	-	M5
5R522	5R544	200	220	10	245	260	7.5	205	-	-	M5
7R522	7R544	200	220	10	245	260	7.5	205	-	-	M5
1122	1144	190	250	30	395	410	7.5	245	-	-	M6
1522	1544	190	250	30	395	410	7.5	245	-	-	M6
2222	2244	240	300	30	445	460	7.5	270	-	-	M6
3022	3044	300	400	50	530	550	10	265	-	-	M8
3722	3744	300	420	60	530	550	10	265	-	-	M8
4522	4544	410	495	42.5	575	600	12.5	270	-	-	M10

Inverter model		Dimension (Unit: mm)									Screw size
200 V class	400 V class	A	B	C	D	E	F	G	H	I	X
5522	5544	410	495	42.5	575	600	12.5	270	-	-	M10
7522	7544	410	500	45	695	720	12.5	350	145	205	M10
9022	—	530	623	46.5	745	770	12.5	350	145	205	M10
—	11044	530	623	46.5	745	770	12.5	350	145	205	M10
—	16044	410	503	46.5	975	1000	12.5	350	145	205	M10

※ For weight of the inverter, refer to {9.2 List of Capacity}.

■ Large type

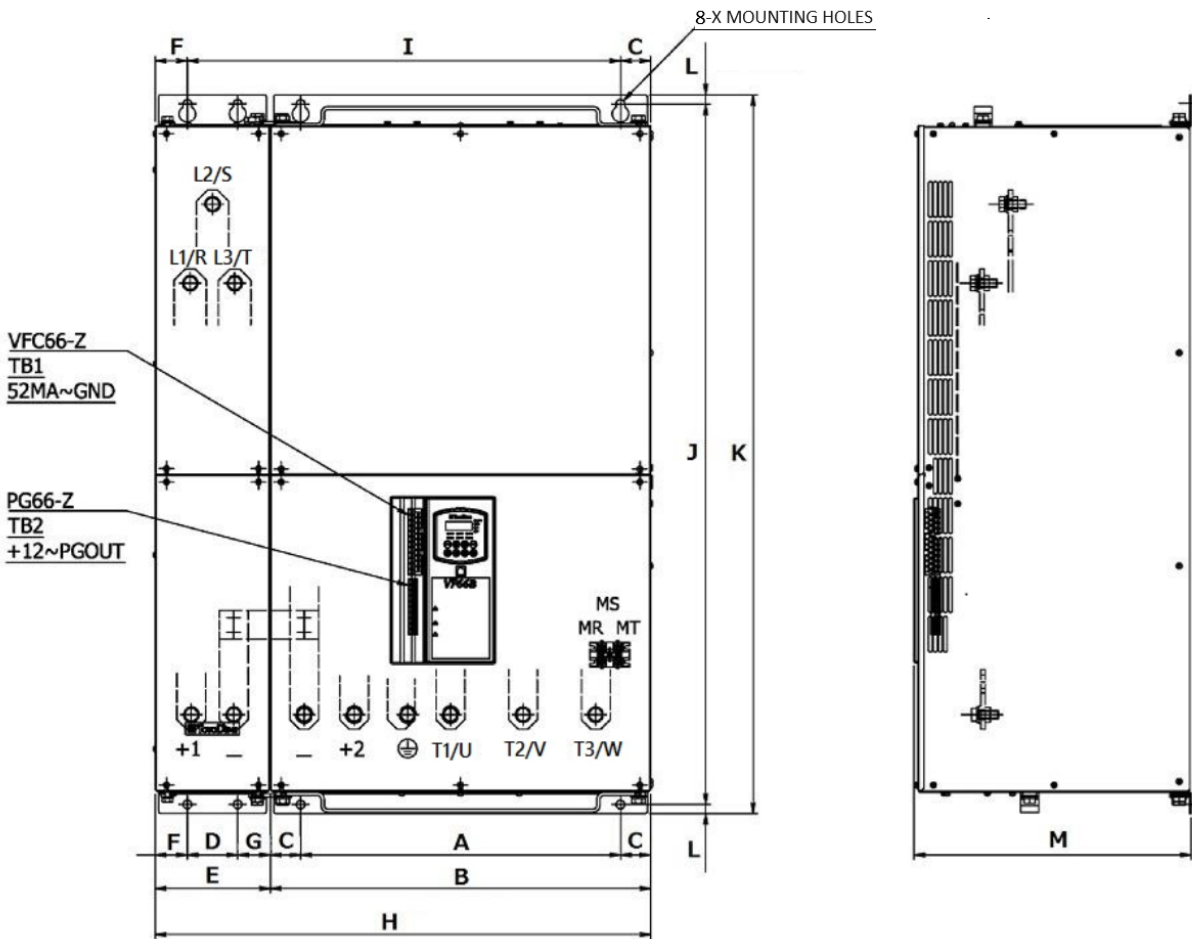

Inverter model	Dimension (Unit: mm)								
400 V class	A	B	C	D	E	F	G	H	I
20044	445	525	40	70	160	42.5	47.5	685	602.5
25044	445	525	40	70	160	42.5	47.5	685	602.5
31544	520	660	70	100	200	49.5	50.5	860	740.5

Inverter model	Dimension (Unit: mm)				Screw size
	J	K	L	M	
400 V class					X
20044	975	1000	12.5	386	M10
25044	975	1000	12.5	386	M10
31544	1100	1130	15	500	M12

※ For weight of the inverter, refer to {9.2 List of Capacity}.

## 10.2 Non-standard Type (Heat Generation Part Protruded Outside)

The heat generation part of the non-standard type inverter is protruded outside from the control panel and others. Its installation requires a through hole.

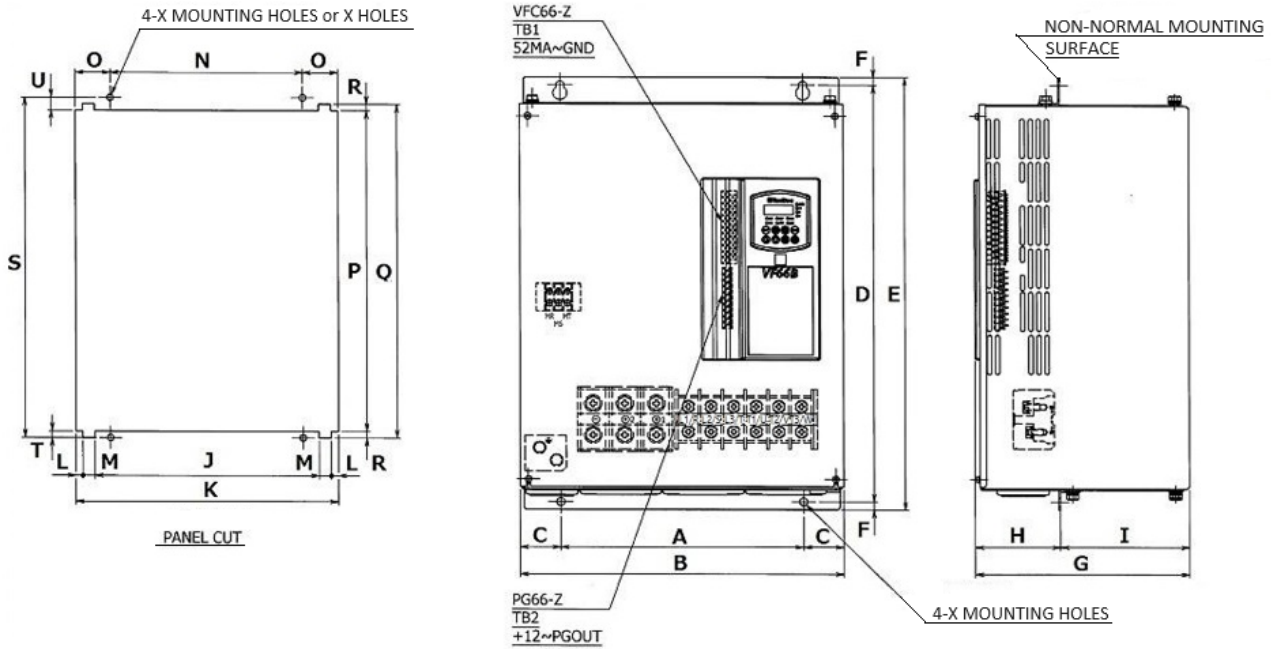

Inverter		Dimension (Unit: mm)								
200 V class	400 V class	A	B	C	D	E	F	G	H	I
2R222	2R244	100	150	25	285	300	7.5	195	103	92
3R722	3R744	100	150	25	285	300	7.5	195	103	92
5R522	5R544	200	220	10	285	300	7.5	205	112.6	92.4
7R522	7R544	200	220	10	285	300	7.5	205	112.6	92.4
1122	1144	190	250	30	395	410	7.5	245	90	155
1522	1544	190	250	30	395	410	7.5	245	90	155
2222	2244	240	300	30	445	460	7.5	270	115	155
3022	3044	300	400	50	530	550	10	265	105	160
3722	3744	300	420	60	530	550	10	265	110	160
4522	4544	410	495	42.5	575	600	12.5	270	105.5	164.5
5522	5544	410	495	42.5	575	600	12.5	270	105.5	164.5
7522	7544	410	500	45	695	720	12.5	350	145	205
9022	—	530	623	46.5	745	770	12.5	305	145	205
—	11044	530	623	46.5	745	770	12.5	305	145	205
—	16044	410	503	46.5	975	1000	12.5	350	145	205

The tables below list the dimensions of the through hole.

Inverter model		Dimension (Unit: mm)								
200 V class	400 V class	J	K	L	M	N	O	P	Q	R
2R222	2R244	–	152	–	–	100	26	272	–	–
3R722	3R744	–	152	–	–	100	26	272	–	–
5R522	5R544	–	217	–	–	200	8.5	274	–	–
7R522	7R544	–	217	–	–	200	8.5	274	–	–
1122	1144	206	260	11	16	190	35	362	380	9
1522	1544	206	260	11	16	190	35	362	380	9
2222	2244	264	310	–	23	240	35	425	435	5
3022	3044	349	409	11	19	300	54.5	500	520	10
3722	3744	369	424	–	27.5	300	62	500	520	10
4522	4544	442	510	12	22	410	50	537	549	–
5522	5544	442	510	12	22	410	50	537	549	–
7522	7544	–	515	–	–	410	52.5	658	–	–
9022	—	–	635	–	–	530	52.5	708	–	–
—	11044	–	635	–	–	530	52.5	708	–	–
—	16044	–	515	–	–	410	52.5	940	–	–

Inverter model		Dimension (Unit: mm)			Screw size
200 V class	400 V class	S	T	U	X
2R222	2R244	285	6.5	6.5	M5
3R722	3R744	285	6.5	6.5	M5
5R522	5R544	285	5.5	5.5	M5
7R522	7R544	285	5.5	5.5	M5
1122	1144	395	11.7	21.3	M6
1522	1544	395	11.7	21.3	M6
2222	2244	445	5	10	M6
3022	3044	530	10	20	M8
3722	3744	530	10	20	M8
4522	4544	575	12	26	M10
5522	5544	575	12	26	M10
7522	7544	695	11	26	M10
9022	—	745	11	26	M10
—	11044	745	11	26	M10
—	16044	975	11	24	M10

※ For weight of the inverter, refer to {9.2 List of Capacity}.

## Chapter 11 Supporting Overseas Standards

This inverter has been tested in accordance with European Low Voltage Directive, EMC (Electro Magnetic Compatibility) Directive, Machinery Directive, and the North American standard UL508C. The test results demonstrate that the inverter conforms to each directive and standard listed in the table below. However, only incorporating our inverter and a supported option into a device does not mean that the entire device conforms to Low Voltage Directive, EMC Directive, Machinery Directive, and the UL standard. The customer who has assembled a final product will be liable for conformity with each directive and standard of the entire device. The customer should check the conformity with each directive and standard of the final product. For supporting overseas standards, refer to another manual "VF66B Overseas Standard Support Instruction Manual."

### Compatible standards

Low Voltage Directive 2014/35/EU	EN 61800-5-1:2007/A1:2017	
EMC Directive 2014/30/EU	Emission	EN IEC 61800-3:2018 Environment II category C3 EN 55011:2016/A1:2017 Group1 Class A
	Immunity	EN IEC 61800-3:2018 Environment II category C3 EN 61326-3-1:2017 SIL2 * <sup>1</sup>
Machinery Directive 2006/42/EC	EN 61800-5-2:2017 STO EN ISO 13849-1:2015 Category3 PL d EN 61508:2010 SIL2 EN 62061:2005/A2:2015 SIL2 EN 60204-1:2018 Stop Category 0	
UL Standard	UL508C * <sup>2</sup>	

- \* 1: Only the inverter which conforms to Machinery Directive corresponds.
- \* 2: Parallel models are not compliant with UL508C.

## Chapter 12 Attentions for Contacting Us

If you want to order a replacement for a failed part or have a technical question, let us or your supplier know the issues below.

- (1) Model, capacity (kW), and input voltage (V) of your inverter
- (2) Model, capacity (kW), rated speed (r/min), rated voltage (V), and number of poles of your motor
- (3) Serial number and software version No. of your inverter
  - For the software version No., check a label attached to the control board <VFC66-Z> as shown in the figure to the right.
- (4) Descriptions of a failure and a state when it occurs
- (5) Operating state, load state, ambient condition, date of purchase, operation condition
- (6) Distributor name, sales department name

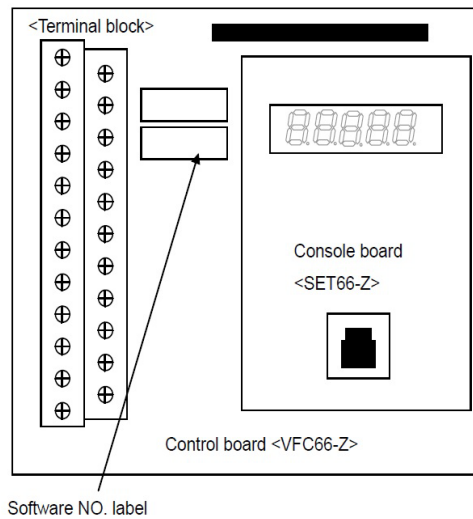

### ■ Attentions to distributors

When delivering this inverter with your any product built in, consider that this manual can be distributed to end users.

Also, when changing our Initialized data for setting parameters of this inverter, consider that the changed value would be delivered to end users.

## Chapter 13 Industrial Product Warranty

### 13.1 No-charge warranty period

The free of charge warranty period shall be "less than 1 year after installation in your company or your customers" or "less than 18 months after shipment from the factory or storage warehouse," whichever comes first.

In the case of repair, overhaul or other maintenance by Toyo Denki or a company designated by Toyo Denki, the warranty period for the parts concerned shall be for one year from the date of acceptance inspection.

### 13.2 Warranty scope

#### 13.2.1 Problem diagnosis

As a general rule, initial diagnosis in the event of product failure should be performed by your company. However, if you request initial problem diagnosis, it can be performed on your behalf by Toyo Denki or a member of our service network.

Please note that if Toyo Denki is not responsible for the cause of the failure, a fee will be charged for the initial diagnosis.

#### 13.2.2 Repair

Repair, part replacement, and onsite repair shall be provided free of charge.

However, this shall not apply in the following cases:

- ① When the problem is a result of improper product handling, conditions, environment, usage method, etc., by you or your customer
- ② When the problem was caused by a system designed by you or your customer
- ③ When the problem was caused by deficiencies in a program created by you or your customer
- ④ When the problem originated in something other than the delivered product
- ⑤ When the problem was caused by modification performed without the prior approval of Toyo Denki
- ⑥ When the problem was caused by repair or modification performed by someone other than Toyo Denki or a company designated by Toyo Denki
- ⑦ When the problem was caused by a force majeure such as a natural disaster, fire, or accident.
- ⑧ Other cases where Toyo Denki is not responsible for the cause of the problem
- ⑨ The no-charge warranty period has expired

### **13.3 Disclaimer**

Irrespective of whether the no-charge warranty period is in effect, this warranty shall not compensate you or your customer for any damages that are not the responsibility of Toyo Denki, or for any lost opportunity, lost profit, secondary damages, or accident due to the failure of the Toyo Denki product concerned. Moreover, compensation shall not be provided relating to articles other than the Toyo Denki product concerned.

### **13.4 Repair period after product discontinuation**

Once the product has gone out of production, Toyo Denki will continue to provide repair service for the product for a period of seven years.

However, please note that the procurement of electronic components for the product may become difficult during that time, and repair may not be possible.

### **13.5 Delivery conditions**

In the case of standard products ordered without test operation and adjustment, delivery shall take place upon product arrival at your company, and Toyo Denki shall not be responsible for onsite test operation and adjustments.

#### **All Rights**

The copyright of this manual belongs to Toyo Denki. Duplicating all or part of contents of this manual without obtaining permission from the right holder is prohibited under the Copyright Act.

All rights of company names and product names described in this manual belong to their respective owners.

---

# INDEX

---

<b>%</b>	
% torque command	191

<b>4</b>	
4 to 20 mA input	262

<b>5</b>	
52MA	33, 73

<b>6</b>	
6F	168

<b>8</b>	
86A	33, 73, 288, 321

<b>A</b>	
Absolute value torque command	191
AC initial excitation	225, 226
Acceleration time	96
Acceleration/Deceleration_time_selection	176
[AIN1]	107, 166
AIN1	33
[ALM] LED	325, 330
Analog input monitor display selection	209
Analog input torque command gain	223
Analog_input_ZeroLimit_voltage	168
AOT1	33
Area A	144
Area b	157
Area c	171
Area d	182
Area E	187
Area F	195
Area G	204
Area H	210

Area i	219
Area J	228
Area L	231
Area n	232
Area o	233
Area P	234
Area S	235, 239
ASR	225
Auto boost	190
Autotuning	14, 78, 80, 83, 317

<b>B</b>	
Blown fuse	292, 293, 294, 295

<b>C</b>	
Calibration	169
category	365
Charging resistance overheat	290
Command_input_when_coupled	161
Communication time error	289
Communication timeout error	290
Console	16, 47
Control board	17
Converter overheat	293, 294, 295
CPU abnormality handling	290
Creep_speed	227
Cumulative operation time	73
Cumulative operation timer	197
Current sensor abnormality	289
Current_control_integral_gain	193
Current_control_proportion_gain	193

<b>D</b>	
D-axis Measurement Mode Autotuning	78
d-axis pulse pole determination	155
DC initial excitation	226
DC_brake_gain	157
DC_brake_operation_time	157
DC_brake_voltage	141
DCL	20, 29, 32
Deceleration stop	158
Deceleration stop with DC brake	158

Deceleration time	96, 182
[ DIR ] LED	75
Direct Current Mode Autotuning	78, 86
Direct-current part overvoltage	290
Direct-current voltage	71, 320
[ ↓ ] key	51
Droop control	220

## E

ED motor	14, 29, 45, 46, 66
EMC Directive	365
Emergency stop	289
Emission	365
Exhaust amount	19
External contact	103, 104
External failure	199, 289

## F

Failed fan	289, 292, 293, 294, 295
FCL operation	289, 292
Flux_command	193
Flux_reinforcing_rate_at_start	193
Forward_direction_change	189
Forward_JOG_frequency	139
Forward_JOG_speed	139
Forward_powering_torque_limit	164
Forward_regenerative_torque_limit	164
Free start	188
Free stop	158
Free_start_maximum_speed	194
Frequency	161
Frequency command value	320
Front cover	16, 21, 25
Full Mode Autotuning	78
[ FWD/REV ] key	51

## G

Gain	256, 267, 274, 281
Gate board abnormality	292
Gate board communication abnormality	292, 293, 294
Gate power supply abnormality	292, 293, 294

## H

High-efficient_mode_usage_selection	189
-------------------------------------	-----

## I

IGBT protection operation	289
Immunity	365
Induction motor	45
Initial_excitation_selection	225
Instantaneous_power_interruption_restart	159
Inverter capacity and voltage class	233
Inverter_operation_mode_monitor	232
Inverter_output_maximum_voltage	194
IO66-Z	209

## J

[ JOG/→ ] key	51, 97
JOG_acceleration/deceleration_time_selection	182
JOG_stop_frequency	157
JOG_stop_mode_selection	157
JOG_stop_speed	157
JOG-command_input_selection	161

## L

Line speed	71
Line_speed_monitor_adjustment	208
Low Voltage Directive	365

## M

Machinery Directive	365
Main circuit board	17
Main unit version	73
Manual boost	190
Maximum_deviation( negative)	187
Maximum_deviation( positive)	187
Maximum_speed	144
MC	293, 294, 295
MC response abnormality	293, 294, 295

Mechanical loss compensation	226
Memory abnormality	289
MI1	33
[ MI1] through [ MI5]	174
Minimum frequency start	188
Minimum_frequency	144
[ MO1]	212
MO1	33
[ MONI/FNC] key	50
Motor overheat	289
Motor speed	71, 320
Motor temperature	71
Motor_cooling_fan( sensor-less_drive)	194
Motor_core_loss_torque_compensation	152, 153
Motor_d-axis_inductance	153
Motor_magnetic_flux	153
Motor_mutual_inductance	152
Motor_overheat_protection_operation_selection	198
Motor_primary_resistance	150, 152, 153
Motor_protect_temperature	209
Motor_q-axis_inductance	153
Motor_secondary_resistance	152
Motor_temperature_compensation	193
Multifunction input terminal	33
Multifunction output terminal	33

## N

Number_of_motor_pole	146
Number_of_moving_pulse_within_a_creep_period	227
Number_of_stop_pulse	227

## O

Offset	256, 267, 274, 281
Open phase	289
Operating digit	57, 59
Operation contact	33
Operation_command_input_selection	161
Optional error	290
OT	202
Output current	71, 320
Output frequency	71, 320
Output torque	71, 320
Output voltage	71, 320
Overcurrent protection	289

Overfrequency protection	289
Overload protection	196, 290
Overspeed protection	290
Overtorque protection	202, 290

## P

Parameter	60, 109, 130, 139
Parameter setting	56, 58
Periodic inspection	324
PG	17, 29, 30, 34
PG error	290
PG_selection	149
PG66-Z	17, 29, 30, 44
PL	365
PLC function	234
Pole_determination_selection	155
Positioning	227
Power supply abnormality	292
Powering_torque_limit	163
Powering_torque_limit_usage_selection	163
P-register_setting	234
Protection contact	33, 288
Protection history	74, 239
Protection operation code	217
Protection_retry_count_setting	199
PS	33
PS common input	29, 103
Pulse train	205
PWM_carrier_frequency	148

## Q

q-axis pulse pole determination	156
q-axis pulse pole determination current	147

## R

Regeneration_stall_prevention_function_usage_selection	187
Regeneration_stall_prevention_voltage	187
Regenerative_torque_limit	163
Regenerative_torque_limit_usage_selection	163
Reset	288, 321
Restart_delay_time	188

Restart_prohibition_time	191
Reverse_JOG_frequency	139
Reverse_JOG_speed	139
Reverse_powering_torque_limit	164
Reverse_prohibition_mode_selection	160
Reverse_regenerative_torque_limit	164

## S

Second setting block selection	179
Sensor error	290
Serial number	25
[SET] key	50
SET66-Z	17, 332
Setting a negative value to a command	97
Setting area	61
Setting block	54
Setting error	290, 312
Setting_data_rewrite_protection	157
Seven-segment display	50
SIL	365
Simple mode	60, 61
Simulation_mode	189
Speed	92, 98, 107
Speed command value	71, 320
Speed control error	203, 290
Speed_command_input_selection	161
Speed_deviation_limiting_command_selection	187
Stabilizer_amount	141
Start error without sensor	290
[START] key	51
Start_mode_selection	188
Startup stall	290
[ST-F]	163
ST-F	29, 33, 72
[STOP/RESET] key	51
Stop_frequency	157
Stop_mode_selection	157
Stop_speed	157
[SW1]	165, 264
[SW2]	169

## T

Temperature_detection_selection	204
Torque command	71, 320

Torque_boost_amount	140
Torque_command_input_place_selection	222
Torque_command_mode_selection	190
Traceback	200
TVTH66-Z	204

## U

UL Standard	365
Unit overheat	292, 293, 294, 295
[↑] key	51

## V

V/f control	14
V/f pattern	192
V/f_pattern_selection	192
Variable structure proportion gain	225
Vector control with sensor	14
Vector control without sensor	14
VFC66-Z	17, 29, 44, 332

---

Blank Page

---



## **TOYODENKI SEIZO K.K.**

<https://www.toyodenki.co.jp/en/>

HEAD OFFICE: Tokyo Tatemono Yaesu Bldg, 1-4-16 Yaesu, Chuo-ku,  
Tokyo, Japan ZIP CODE 103-0028  
TEL : +81-3-5202-8132  
FAX : +81-3-5202-8150

In addition, the contents of this the "operating manual" may be changed without a preliminary announcement by specification change of a product etc. Please understand that it may differ from the contents of the "operating manual" enclosed by the model of purchase, and the contents of the "operating manual" posted on our homepage.

Please have a look from our homepage about the newest "operating manual".